



**Maine Township Board Meeting**  
**Maine Township Town Hall**  
**1700 Ballard Road Park Ridge, IL 60068**  
Tuesday, April 28, 2026

**AGENDA**

This meeting will be conducted in person. The meeting will also be audio or video recorded and made available to the public, as provided by law.

**7:00 pm** - Call Regular Meeting to Order  
Pledge of Allegiance  
Roll Call

**Discussion and Potential Action on the Following Items:**

1. Approval of Minutes of the March 24, 2026 Board Meeting
2. Approval of General Assistance Expenditures
3. Approval of Road District Expenditures
4. Approval of General Town Fund Expenditures
5. Public Participation
6. Anniversary Milestones – Richard Lyon, 20 Years of Service
7. Old Business
  - Discussion and Possible Vote on Clinical Observation and Recording System Improvements
  - Discussion of Solid Waste Collection and Recycling Services
8. New Business
  - Presentation by Catherine Sbarra from Webb Insurance Group
  - Discussion and Possible Vote on Insurance Renewal
  - Discussion and vote on an Ordinance Approving a Purchase and Sale Agreement for the Purchase of the Property Located at 9850 Milwaukee Avenue from Chicago Title and Land Trust Company
  - Discussion of Town Fund/General Assistance Tentative Budget & Appropriation Ordinance for 2026-27
  - Discussion and Possible Vote to Approve Amendments to Public Relations Marketing Agreement
  - Discussion and Vote on Resolution 2026-7, a Resolution Approving and Making a Determination on Executive Session Meeting Minutes
  - Discussion and Possible Vote to Approve Engagement Letter with Evans Marshall and Pease

9. Officials Reports

10. Closed/Executive Session – pursuant to Section 2(c)(1) of the Open Meetings Act; discussing the appointment, employment, compensation, discipline, performance, or dismissal of specific employees; and pursuant to Section 2(c)(5) of the Open Meetings Act to discuss the purchase or lease of real property for the use of the public body, including meetings held for the purpose of discussing whether a particular parcel should be acquired; and pursuant to Section 2(c)(11) of the Open Meetings Act litigation which is probable or imminent.

11. Adjournment

**Upcoming Events**

May 1, 2026	Agency Day
May 6, 2026	Neighborhood Watch
May 16, 2026	Shredding Event
June 6, 2026	Water and Wellness Event

**Upcoming Board Meetings**

May 26, 2026  
June 30, 2026  
July 28, 2026



4/28/26

---

**TO:** Elected Officials

**FROM:** Victoria Rizzo, Administrator

---

**SUBJECT:** ADMINISTRATOR'S REPORT – APRIL 2026

---

This month, we welcomed two new employees to town hall. Laura Sissman is the Afternoon Receptionist and Dena Ismail is the new Deputy Clerk. We are also hiring a full time Assistant to the Supervisor and a part time Finance Assistant. The General Assistant department is also seeking a full time Senior and Disability Advocate. Visit [mainetown.com/jobs](http://mainetown.com/jobs) to learn more and apply!

On April 7, the Niles Chamber of Commerce hosted a Legislative Breakfast to bring together elected officials and local business leaders. Supervisor Jones was a panelist and shared her insight on the important work the township does and its connection to the business community. Deputy Administrator Ruba Al Ayed and I attended this event as well, and were able to network with colleagues and make some new great connections.

Also on April 7, Supervisor Jones, Ruba, and I had the opportunity to visit Oakton College to learn about the wonderful work that they do for the community and accepted a generous donation to the Food Pantry from the Empty Bowls event that they host each year. Later that evening, North Suburban Legal Aid held a Tenants Rights Presentation where tenants learned more about their rights, the eviction process and available rent assistance options. GA Director Luz Meneses and Assistant Director Stephanie Janas also answered questions and shared their expertise with attendees about other programs that can help them.

Maine Township is accepting proposals for residential solid waste collection services, recycling services, landscape waste collection and disposal services and the billing of residents in the unincorporated area of Maine Township. Proposals are due no later than May 15, 2026. We encourage residents who would like to share their opinion to the township board about the waste hauler agreement and submissions to attend the May 26, 2026 board meeting and speak during public participation.

We collaborated with Senator Laura Murphy (28<sup>th</sup>) to host an electronics recycling event at town hall on April 18 from 9-12 for township residents. Over 165 residents were able to recycle electronics and we were also able to distribute sandbags to others who have been affected by flooding. Thank you to our elected officials, Supervisor Jones, Trustee James Maher and Trustee Malik for your help and to Senator Murphy and her team for their support making this event a success. Once again, the township team rolled up their

sleeves and worked so hard to keep this busy event organized and safe. Thank you to Jack Wisniewski, Gerard Grabowski and Andrew Lechowicz, Michael Samaan, Jonathan Wolf, Arielle Kalvelage, Elio Custic, Monika Jaroszewicz, Jessica Guzman, Jim Doherty, and Ruba Al Ayed whose heavy lifting and teamwork made this event such a success.

We will be back in the parking lot on May 16 from 9 -12 for a Shredding Event. Township residents can bring up to 3 bags to securely shred. For more information about these events, please call town hall. If any elected officials would like to help at these events, please let me know.

On April 14, the township held the Annual Town Meeting at town hall. At the meeting, we celebrated years of service for those who hit a milestone in the past year. Congratulations to Therese Tully, 25 years, Susan Moylan Krey, 20 years and Richard Lyon, 20 years. This meeting was particularly special as we witnessed a historic vote in favor of purchasing a new facility for the food pantry. It was inspiring to be a part of such an important moment for the township, and we are excited for the next phase and continued growth for our services.

Mark your calendars for June 6 for Metropolitan Water Reclamation District Commissioner Eira Corral Sepulveda's annual wellness fair at town hall, where we host a variety of informative and educational tables and learn about the connection between Water and Wellness.

# MAINE TOWNSHIP GENERAL TOWN FUND

<b><u>REVENUE</u></b>						
	<b>MAR</b>	<b>YTD INCOME</b>	<b>BUDGET</b>	<b>BALANCE</b>	<b>% Collected</b>	
Property Tax	\$514,223.63	\$514,223.63	\$3,800,000.00	\$3,285,776.37	<b>14%</b>	
Interest Income	\$11,340.04	\$11,340.04	\$200,000.00	\$188,659.96	<b>6%</b>	
MaineStay Income	\$1,805.00	\$1,805.00	\$60,000.00	\$58,195.00	<b>3%</b>	
Yard Stickers and Rebates	\$71.50	\$71.50	\$8,000.00	\$7,928.50	<b>1%</b>	
Postage	\$0.00	\$0.00	\$5,000.00	\$5,000.00	<b>0%</b>	
Passport Fees	\$3,454.00	\$3,454.00	\$50,000.00	\$46,546.00	<b>7%</b>	
Transportation Fees	\$0.00	\$0.00	\$400.00	\$400.00	<b>0%</b>	
Prsnl Prop Replacement Tax	\$5,657.32	\$5,657.32	\$200,000.00	\$194,342.68	<b>3%</b>	
Other Income	\$18,893.00	\$18,893.00	\$20,000.00	\$1,107.00	<b>94%</b>	
Hunting/Fishing License	\$66.75	\$66.75	\$1,500.00	\$1,433.25	<b>4%</b>	
Recovery Connection Grant	\$0.00	\$0.00	\$30,000.00	\$30,000.00	<b>0%</b>	
License Plate Stickers	\$1,504.00	\$1,504.00	\$20,000.00	\$18,496.00	<b>8%</b>	
<b>TOTAL REVENUES</b>	<b>\$557,015.24</b>	<b>\$557,015.24</b>	<b>\$4,394,900.00</b>	<b>\$3,837,884.76</b>	<b>13%</b>	
<i>MaineStreamers</i>	\$10,442.64	\$10,442.64				

# MAINE TOWNSHIP GENERAL TOWN FUND

	<b><u>EXPENSES</u></b>					
	<b>ADMINISTRATION</b>					
<b>92%</b>	<b>of the year remaining</b>	<b>MAR</b>	<b>YTD EXPENSE</b>	<b>BUDGET</b>	<b>BALANCE</b>	<b>% Left</b>
	Salaries/Gross Pay Account	\$42,214.90	\$42,214.90	\$800,000.00	\$757,785.10	<b>95%</b>
	Salaries/Elected Officials	\$14,995.63	\$14,995.63	\$180,000.00	\$165,004.37	<b>92%</b>
	IDES	\$605.00	\$605.00	\$8,001.00	\$7,396.00	<b>92%</b>
	Tuition Reimbursement	\$0.00	\$0.00	\$1.00	\$1.00	<b>100%</b>
	Social Security	\$4,184.80	\$4,184.80	\$69,000.00	\$64,815.20	<b>94%</b>
	IMRF	\$1,920.85	\$1,920.85	\$64,000.00	\$62,079.15	<b>97%</b>
	Administrative Div. Health Ins.	\$31,693.97	\$31,693.97	\$310,000.00	\$278,306.03	<b>90%</b>
	Life Insurance	\$187.20	\$187.20	\$1,500.00	\$1,312.80	<b>88%</b>
	Dental Insurance	\$1,003.03	\$1,003.03	\$6,000.00	\$4,996.97	<b>83%</b>
	Bookkeeper/Accounting Service	\$7,916.64	\$7,916.64	\$75,000.00	\$67,083.36	<b>89%</b>
	Audit Services	\$0.00	\$0.00	\$15,000.00	\$15,000.00	<b>100%</b>
	Building & Grounds Maint	\$1,538.04	\$1,538.04	\$30,000.00	\$28,461.96	<b>95%</b>
	Community Info-Support	\$3,450.00	\$3,450.00	\$40,000.00	\$36,550.00	<b>91%</b>
	Conferences Meetings	\$0.00	\$0.00	\$2,500.00	\$2,500.00	<b>100%</b>
	Special Programs	\$50.00	\$50.00	\$17,000.00	\$16,950.00	<b>100%</b>
	Dues Subscriptions	\$3,495.69	\$3,495.69	\$10,000.00	\$6,504.31	<b>65%</b>
	Equipment Leasing Maint	\$1,335.01	\$1,335.01	\$17,000.00	\$15,664.99	<b>92%</b>
	Gen Ins Liability Ins Bond	\$0.00	\$0.00	\$67,000.00	\$67,000.00	<b>100%</b>
	Website\Email Host	\$4,500.00	\$4,500.00	\$29,000.00	\$24,500.00	<b>84%</b>
	Print Management	\$0.00	\$0.00	\$2,000.00	\$2,000.00	<b>100%</b>
	Computer Tech Support	\$719.20	\$719.20	\$4,500.00	\$3,780.80	<b>84%</b>
	Legal Services	\$3,203.50	\$3,203.50	\$40,000.00	\$36,796.50	<b>92%</b>
	Mileage-Travel-Lodging Exp	\$28.06	\$28.06	\$5,000.00	\$4,971.94	<b>99%</b>
	Police Protection	\$2,800.00	\$2,800.00	\$51,000.00	\$48,200.00	<b>95%</b>
	Plan Commission	\$0.00	\$0.00	\$1.00	\$1.00	<b>100%</b>
	Postage	\$14,781.29	\$14,781.29	\$55,000.00	\$40,218.71	<b>73%</b>
	Printing Publishing	\$15,114.77	\$15,114.77	\$72,000.00	\$56,885.23	<b>79%</b>
	Code Enforcement Expense	\$0.00	\$0.00	\$1,000.00	\$1,000.00	<b>100%</b>
	Maine Township Rec. Connection	\$4,298.27	\$4,298.27	\$70,000.00	\$65,701.73	<b>94%</b>

# MAINE TOWNSHIP GENERAL TOWN FUND

Telecommunications	\$2,068.32	\$2,068.32	\$30,000.00	\$27,931.68	<b>93%</b>
Staff Training	\$0.00	\$0.00	\$1,000.00	\$1,000.00	<b>100%</b>
Transportation/Mainelines	\$100.00	\$100.00	\$1,500.00	\$1,400.00	<b>93%</b>
Utilities	\$2,886.51	\$2,886.51	\$33,000.00	\$30,113.49	<b>91%</b>
Miscellaneous (Administr)	\$226.72	\$226.72	\$750.00	\$523.28	<b>70%</b>
PACE	\$690.40	\$690.40	\$4,750.00	\$4,059.60	<b>85%</b>
National Night Out	\$0.00	\$0.00	\$5,000.00	\$5,000.00	<b>100%</b>
Office Supplies/Sm. Equipment	\$1,506.87	\$1,506.87	\$28,000.00	\$26,493.13	<b>95%</b>
Operating Supplies Maint	\$251.68	\$251.68	\$18,500.00	\$18,248.32	<b>99%</b>
Vehicle Expense	\$244.95	\$244.95	\$4,000.00	\$3,755.05	<b>94%</b>
Building	\$0.00	\$0.00	\$45,000.00	\$45,000.00	<b>100%</b>
Project Clean-up/Waste Hauler	\$3,330.00	\$3,330.00	\$15,000.00	\$11,670.00	<b>78%</b>
Capital Fund	\$0.00	\$0.00	\$150,000.00	\$150,000.00	<b>100%</b>
Contingency	\$0.00	\$0.00	\$69,685.00	\$69,685.00	<b>100%</b>
<b>Total</b>	<b>\$171,341.30</b>	<b>\$171,341.30</b>	<b>\$2,447,688.00</b>	<b>\$2,276,346.70</b>	<b>93%</b>

# MAINE TOWNSHIP GENERAL TOWN FUND

	<b>ASSESSOR</b>					
<b>92%</b>	<b>of the year remaining</b>	<b>MAR</b>	<b>YTD EXPENSE</b>	<b>BUDGET</b>	<b>BALANCE</b>	<b>% Left</b>
	Assessor Division Salary	\$19,990.76	\$19,990.76	\$292,320.00	\$272,329.24	<b>93%</b>
	Assessor Division SS	\$1,443.25	\$1,443.25	\$20,807.00	\$19,363.75	<b>93%</b>
	Assessor Division IMRF	\$1,072.12	\$1,072.12	\$17,128.00	\$16,055.88	<b>94%</b>
	Health Insurance	\$17,143.04	\$17,143.04	\$138,240.00	\$121,096.96	<b>88%</b>
	Dental Insurance	\$429.72	\$429.72	\$3,000.00	\$2,570.28	<b>86%</b>
	Life Insurance	\$43.20	\$43.20	\$300.00	\$256.80	<b>86%</b>
	Conferences Meetings	\$0.00	\$0.00	\$1,300.00	\$1,300.00	<b>100%</b>
	Cook Cty Assessor Tie-in	\$0.00	\$0.00	\$1,050.00	\$1,050.00	<b>100%</b>
	Dues-Subscriptions	\$75.00	\$75.00	\$570.00	\$495.00	<b>87%</b>
	Equipment Leasing-Maint	\$0.00	\$0.00	\$1.00	\$1.00	<b>100%</b>
	Mileage-Travel-Lodging Exp	\$0.00	\$0.00	\$1,500.00	\$1,500.00	<b>100%</b>
	Postage	\$57.74	\$57.74	\$1,200.00	\$1,142.26	<b>95%</b>
	Printing-Publishing	\$0.00	\$0.00	\$800.00	\$800.00	<b>100%</b>
	Sidwell Maps	\$0.00	\$0.00	\$700.00	\$700.00	<b>100%</b>
	Staff Training	\$0.00	\$0.00	\$150.00	\$150.00	<b>100%</b>
	Miscellaneous	\$0.00	\$0.00	\$2,000.00	\$2,000.00	<b>100%</b>
	Office Supplies/Sm Equipment	\$0.00	\$0.00	\$4,300.00	\$4,300.00	<b>100%</b>
	<b>Total</b>	<b>\$40,254.83</b>	<b>\$40,254.83</b>	<b>\$485,366.00</b>	<b>\$445,111.17</b>	<b>92%</b>

# MAINE TOWNSHIP GENERAL TOWN FUND

	<b>MAINESTAY</b>					
<b>92%</b>	<b>of the year remaining</b>	<b>MAR</b>	<b>YTD EXPENSE</b>	<b>BUDGET</b>	<b>BALANCE</b>	<b>% Left</b>
	MaineStay Salary	\$30,047.74	\$30,047.74	\$415,000.00	\$384,952.26	<b>93%</b>
	Social Security	\$2,213.54	\$2,213.54	\$32,000.00	\$29,786.46	<b>93%</b>
	IMRF	\$1,911.04	\$1,911.04	\$29,000.00	\$27,088.96	<b>93%</b>
	Administrative Div. Health Ins.	\$19,383.82	\$19,383.82	\$125,000.00	\$105,616.18	<b>84%</b>
	Life Ins.	\$86.40	\$86.40	\$500.00	\$413.60	<b>83%</b>
	Dental Ins.	\$417.92	\$417.92	\$2,200.00	\$1,782.08	<b>81%</b>
	Conferences-Meetings	\$0.00	\$0.00	\$700.00	\$700.00	<b>100%</b>
	Consultation/Staff Training	\$1,225.00	\$1,225.00	\$1,700.00	\$475.00	<b>28%</b>
	Special Programs	\$4,664.30	\$4,664.30	\$19,000.00	\$14,335.70	<b>75%</b>
	Dues-Subscriptions/Licensures	\$257.42	\$257.42	\$5,500.00	\$5,242.58	<b>95%</b>
	Print Management	\$0.00	\$0.00	\$1,850.00	\$1,850.00	<b>100%</b>
	Gen Ins Liability Ins Bond	\$0.00	\$0.00	\$750.00	\$750.00	<b>100%</b>
	Computer Tech Support	\$359.60	\$359.60	\$4,500.00	\$4,140.40	<b>92%</b>
	Mileage-Travel-Lodging Exp	\$0.00	\$0.00	\$1,500.00	\$1,500.00	<b>100%</b>
	Postage	\$0.00	\$0.00	\$100.00	\$100.00	<b>100%</b>
	Printing-Publishing	\$0.00	\$0.00	\$600.00	\$600.00	<b>100%</b>
	Community Education	\$457.29	\$457.29	\$100.00	-\$357.29	<b>-357%</b>
	Training Manual & Books	\$0.00	\$0.00	\$365.00	\$365.00	<b>100%</b>
	Miscellaneous	\$0.00	\$0.00	\$50.00	\$50.00	<b>100%</b>
	Office Supplies/Sm Equipment	-\$78.04	-\$78.04	\$3,600.00	\$3,678.04	<b>102%</b>
	Youth Recreation Fund	\$0.00	\$0.00	\$3,000.00	\$3,000.00	<b>100%</b>
	Summer Youth Camp	\$0.00	\$0.00	\$16,300.00	\$16,300.00	<b>100%</b>
	Garage Sale	\$0.00	\$0.00	\$1,000.00	\$1,000.00	<b>100%</b>
	<b>Total</b>	\$60,946.03	\$60,946.03	\$664,315.00	\$603,368.97	<b>91%</b>

# MAINE TOWNSHIP GENERAL TOWN FUND

	<b>SENIOR</b>					
<b>92%</b>	<b>of the year remaining</b>	<b>MAR</b>	<b>YTD EXPENSE</b>	<b>BUDGET</b>	<b>BALANCE</b>	<b>% Left</b>
	Senior Salary	\$23,040.48	\$23,040.48	\$305,500.00	\$282,459.52	<b>92%</b>
	Social Security	\$1,716.30	\$1,716.30	\$24,000.00	\$22,283.70	<b>93%</b>
	IMRF	\$1,465.38	\$1,465.38	\$23,000.00	\$21,534.62	<b>94%</b>
	Life Ins.	\$57.60	\$57.60	\$350.00	\$292.40	<b>84%</b>
	Dental Ins.	\$348.48	\$348.48	\$1,600.00	\$1,251.52	<b>78%</b>
	Administrative Div. Health Ins.	\$16,560.66	\$16,560.66	\$104,000.00	\$87,439.34	<b>84%</b>
	Conferences-Meetings	\$0.00	\$0.00	\$900.00	\$900.00	<b>100%</b>
	Special Programs	\$350.00	\$350.00	\$8,100.00	\$7,750.00	<b>96%</b>
	Print Management	\$0.00	\$0.00	\$1,700.00	\$1,700.00	<b>100%</b>
	Dues-Subscriptions	\$6,490.78	\$6,490.78	\$7,500.00	\$1,009.22	<b>13%</b>
	Mileage-Travel-Lodging Exp	\$0.00	\$0.00	\$2,100.00	\$2,100.00	<b>100%</b>
	Telecommunications	\$2.55	\$2.55	\$75.00	\$72.45	<b>97%</b>
	Office Supplies/Sm Equipment	\$34.62	\$34.62	\$13,000.00	\$12,965.38	<b>100%</b>
	Computer Tech Support	\$359.60	\$359.60	\$4,500.00	\$4,140.40	<b>92%</b>
	<b>Total</b>	\$50,426.45	\$50,426.45	\$496,325.00	\$445,898.55	<b>90%</b>
	<i>MaineStreamers</i>	\$30,972.82	\$30,972.82			

# MAINE TOWNSHIP GENERAL TOWN FUND

	<b>CLERK</b>					
<b>92%</b>	<b>of the year remaining</b>	<b>MAR</b>	<b>YTD EXPENSE</b>	<b>BUDGET</b>	<b>BALANCE</b>	<b>% Left</b>
	Clerk's Division Salary	\$11,523.40	\$11,523.40	\$175,000.00	\$163,476.60	<b>93%</b>
	Social Security	\$850.38	\$850.38	\$13,400.00	\$12,549.62	<b>94%</b>
	IMRF	\$598.64	\$598.64	\$9,500.00	\$8,901.36	<b>94%</b>
	Administrative Div. Health Ins.	\$10,914.42	\$10,914.42	\$67,500.00	\$56,585.58	<b>84%</b>
	Life Ins.	\$28.80	\$28.80	\$250.00	\$221.20	<b>88%</b>
	Dental Ins.	\$233.72	\$233.72	\$1,250.00	\$1,016.28	<b>81%</b>
	Conferences-Meetings	\$0.00	\$0.00	\$2,000.00	\$2,000.00	<b>100%</b>
	Dues-Subscriptions	\$35.00	\$35.00	\$400.00	\$365.00	<b>91%</b>
	Print Management	\$0.00	\$0.00	\$1,850.00	\$1,850.00	<b>100%</b>
	Mileage-Travel-Lodging Exp	\$0.00	\$0.00	\$2,000.00	\$2,000.00	<b>100%</b>
	Staff Training	\$0.00	\$0.00	\$700.00	\$700.00	<b>100%</b>
	Honor Flight	\$0.00	\$0.00	\$1,000.00	\$1,000.00	<b>100%</b>
	Computer Tech Support	\$359.60	\$359.60	\$4,400.00	\$4,040.40	<b>92%</b>
	Postage	\$581.87	\$581.87	\$8,000.00	\$7,418.13	<b>93%</b>
	Printing-Publishing	\$0.00	\$0.00	\$2,200.00	\$2,200.00	<b>100%</b>
	Miscellaneous	\$0.00	\$0.00	\$100.00	\$100.00	<b>100%</b>
	Office Supplies/Sm Equipment	\$0.00	\$0.00	\$4,500.00	\$4,500.00	<b>100%</b>
	Hunting/Fishing License	\$64.25	\$64.25	\$1,000.00	\$935.75	<b>94%</b>
	License Plate Stickers	\$1,312.70	\$1,312.70	\$20,000.00	\$18,687.30	<b>93%</b>
	<b>Total</b>	<b>\$26,502.78</b>	<b>\$26,502.78</b>	<b>\$315,050.00</b>	<b>\$288,547.22</b>	<b>92%</b>

# MAINE TOWNSHIP GENERAL TOWN FUND

	<b>OEM</b>					
<b>92%</b>	<b>of the year remaining</b>	<b>MAR</b>	<b>YTD EXPENSE</b>	<b>BUDGET</b>	<b>BALANCE</b>	<b>% Left</b>
	Emergency Mgmt Salary	\$1,592.86	\$1,592.86	\$38,000.00	\$36,407.14	<b>96%</b>
	OEM Social Security	\$121.87	\$121.87	\$2,900.00	\$2,778.13	<b>96%</b>
	Uniforms	\$0.00	\$0.00	\$4,000.00	\$4,000.00	<b>100%</b>
	Conferences-Meetings	\$0.00	\$0.00	\$500.00	\$500.00	<b>100%</b>
	Special Programs	\$0.00	\$0.00	\$1,500.00	\$1,500.00	<b>100%</b>
	Dues-Subscriptions	\$0.00	\$0.00	\$400.00	\$400.00	<b>100%</b>
	Volunteer Insurance	\$0.00	\$0.00	\$1,000.00	\$1,000.00	<b>100%</b>
	Utilities	\$783.76	\$783.76	\$4,500.00	\$3,716.24	<b>83%</b>
	Telecommunications	\$529.71	\$529.71	\$3,900.00	\$3,370.29	<b>86%</b>
	Staff Training	\$0.00	\$0.00	\$1,500.00	\$1,500.00	<b>100%</b>
	Office Supplies/Sm Equipment	\$0.00	\$0.00	\$10,100.00	\$10,100.00	<b>100%</b>
	Operating Supplies	\$0.00	\$0.00	\$10,000.00	\$10,000.00	<b>100%</b>
	Disaster Operations Supplies	\$0.00	\$0.00	\$3,000.00	\$3,000.00	<b>100%</b>
	Building	\$0.00	\$0.00	\$8,000.00	\$8,000.00	<b>100%</b>
	Vehicle Expense	\$0.00	\$0.00	\$7,000.00	\$7,000.00	<b>100%</b>
	<b>Total</b>	\$3,028.20	\$3,028.20	\$96,300.00	\$93,271.80	<b>97%</b>

# MAINE TOWNSHIP GENERAL TOWN FUND

	Mental Health/Comm Serv.	\$25,524	\$25,524	\$472,500	\$446,976	<b>95%</b>
	<b>Total Operating Exp</b>	<b>\$378,024</b>	<b>\$337,769</b>	<b>\$4,977,544</b>	<b>\$4,154,409</b>	<b>83%</b>

**MAINE TOWNSHIP GENERAL ASSISTANCE FUND**

	<b>REVENUE</b>	<b>MAR</b>	<b>YTD INCOME</b>	<b>BUDGET</b>	<b>BALANCE</b>	<b>% Collected</b>
Property Tax	\$128,548.10	\$128,548.10	\$800,000.00	\$671,451.90	16%	
SS Reimbursement	\$0.00	\$0.00	\$27,500.00	\$27,500.00	0%	
Interest Income	\$4,409.08	\$4,409.08	\$20,000.00	\$15,590.92	22%	
Energy Assistance Revenue	\$2,637.00	\$2,637.00	\$18,000.00	\$15,363.00	15%	
Other Income	\$0.00	\$0.00	\$12,000.00	\$12,000.00	0%	
<b>TOTAL REVENUES</b>	<b>\$135,594.18</b>	<b>\$135,594.18</b>	<b>\$877,500.00</b>	<b>\$741,905.82</b>	<b>15%</b>	
<b>EXPENSES</b>						
<b>EXPENSES-ADMINISTRATIVE</b>						
<b>92%</b>	<b>of the year remaining</b>	<b>MAR</b>	<b>YTD EXPENSE</b>	<b>BUDGET</b>	<b>BALANCE</b>	<b>% Left</b>
	Salaries	\$22,897.52	\$22,897.52	\$378,000.00	\$355,102.48	94%
	IDES	\$0.00	\$0.00	\$1.00	\$1.00	100%
	Social Security	\$1,697.08	\$1,697.08	\$25,000.00	\$23,302.92	93%
	IMRF	\$1,241.86	\$1,241.86	\$23,000.00	\$21,758.14	95%
	Administrative Div. Health Ins.	\$8,046.71	\$8,046.71	\$102,000.00	\$93,953.29	92%
	Life Insurance	\$36.00	\$36.00	\$400.00	\$364.00	91%
	Dental Insurance	\$150.40	\$150.40	\$1,700.00	\$1,549.60	91%
	Tuition Reimbursement	\$0.00	\$0.00	\$1.00	\$1.00	100%
	Accounting Services	\$714.46	\$714.46	\$11,500.00	\$10,785.54	94%
	Conferences Meetings	\$0.00	\$0.00	\$800.00	\$800.00	100%
	Dues Subscriptions	\$0.00	\$0.00	\$100.00	\$100.00	100%
	Print Management	\$0.00	\$0.00	\$1,850.00	\$1,850.00	100%
	General Insurance-Liab-Bond	\$0.00	\$0.00	\$7,500.00	\$7,500.00	100%
	Mileage-Travel-Lodging	\$0.00	\$0.00	\$1,000.00	\$1,000.00	100%
	Postage	\$134.83	\$134.83	\$4,000.00	\$3,865.17	97%
	Printing Publishing	\$0.00	\$0.00	\$800.00	\$800.00	100%
	Staff Training	\$0.00	\$0.00	\$1,000.00	\$1,000.00	100%
	Hearing Officer	\$0.00	\$0.00	\$1.00	\$1.00	100%
	Food Pantry	\$0.00	\$0.00	\$12,000.00	\$12,000.00	100%
	Miscellaneous	\$39.39	\$39.39	\$1.00	-\$38.39	-3839%
	Office Supplies	\$0.00	\$0.00	\$3,250.00	\$3,250.00	100%
	Computer Software Development	\$0.00	\$0.00	\$3,000.00	\$3,000.00	100%
	Comp Tech Support	\$359.60	\$359.60	\$4,500.00	\$4,140.40	92%
	Contingencies	\$0.00	\$0.00	\$1,250.00	\$1,250.00	100%
	<b>Total</b>	<b>\$35,317.85</b>	<b>\$35,317.85</b>	<b>\$582,654.00</b>	<b>\$547,336.15</b>	<b>94%</b>

**MAINE TOWNSHIP GENERAL ASSISTANCE FUND**

<b>EXPENSES-ASSISTANCE</b>						
<b>92%</b>	<b>of the year remaining</b>	<b>MAR</b>	<b>YTD EXPENSE</b>	<b>BUDGET</b>	<b>BALANCE</b>	<b>% Left</b>
	Emergency Assist Program	\$0.00	\$0.00	\$10,000.00	\$10,000.00	100%
	Prescription Drugs	\$0.00	\$0.00	\$1,500.00	\$1,500.00	100%
	Dental Services		\$0.00	\$1,000.00	\$1,000.00	100%
	Medical Services	\$0.00	\$0.00	\$500.00	\$500.00	100%
	Funeral & Burial Services	\$0.00	\$0.00	\$1.00	\$1.00	100%
	Client Utilities	\$90.47	\$90.47	\$5,000.00	\$4,909.53	98%
	Shelter-Rent	\$2,001.36	\$2,001.36	\$100,000.00	\$97,998.64	98%
	Ambulance Paramedic	\$0.00	\$0.00	\$1,000.00	\$1,000.00	100%
	Food	\$0.00	\$0.00	\$50,000.00	\$50,000.00	100%
	Pers Essentials	\$701.53	\$701.53	\$25,000.00	\$24,298.47	97%
	Client Health Ins.	\$0.00	\$0.00	\$500.00	\$500.00	100%
	Transient	\$0.00	\$0.00	\$1,000.00	\$1,000.00	100%
	<b>Total</b>	<b>\$2,793.36</b>	<b>\$2,793.36</b>	<b>\$195,501.00</b>	<b>\$192,707.64</b>	<b>99%</b>
	<b>TOTAL OPERATING EXPENSES</b>	<b>\$38,111.21</b>	<b>\$38,111.21</b>	<b>\$778,155.00</b>	<b>\$740,043.79</b>	<b>95%</b>

**MAINE TOWNSHIP ROAD AND BRIDGE FUND**

<b>REVENUE</b>	<b>MAR</b>	<b>YTD INCOME</b>	<b>BUDGET</b>	<b>BALANCE</b>	<b>% Collected</b>
Property Tax	\$415,162.23	\$415,162.23	\$2,271,153	\$1,855,990.77	18%
Interest Income	\$350.00	\$350.00	\$8,000.00	\$7,650.00	4%
Permit Fees		\$0.00	\$6,225.00	\$6,225.00	0%
Other Income	\$1,119.52	\$1,119.52	\$750,000.00	\$748,880.48	0%
Persnl Prop Replacement Tx	\$5,657.52	\$5,657.52	\$291,668.00	\$286,010.48	2%
<b>TOTAL REVENUES</b>	<b>\$422,289.27</b>	<b>\$422,289.27</b>	<b>\$3,327,046.00</b>	<b>\$2,904,756.73</b>	<b>87%</b>

**EXPENSES**

92% of the year remaining	<b>MAR</b>	<b>YTD EXPENSE</b>	<b>BUDGET</b>	<b>BALANCE</b>	<b>% Left</b>
<b>GENERAL ROAD FUND-ADMIN.</b>					
Admin Salary Expense	\$5,740.00	\$5,740.00	\$153,180.00	\$147,440.00	96%
Health Insurance	\$29,920.18	\$29,920.18	\$247,500.00	\$217,579.82	88%
Life Insurance	\$72.00	\$72.00	\$1,000.00	\$928.00	93%
Dental Insurance	\$655.84	\$655.84	\$8,000.00	\$7,344.16	92%
Alcohol & Drug Testing	\$35.00	\$35.00	\$1,000.00	\$965.00	97%
Payroll Service	\$1,073.94	\$1,073.94	\$8,000.00	\$6,926.06	87%
Accounting Services	\$0.00	\$0.00	\$8,000.00	\$8,000.00	100%
Conferences Meetings	\$0.00	\$0.00	\$2,000.00	\$2,000.00	100%
Community Outreach	\$2,000.00	\$2,000.00	\$50,000.00	\$48,000.00	96%
Dues Subscriptions	\$85.00	\$85.00	\$20,000.00	\$19,915.00	100%
Legal Services	\$15,000.00	\$15,000.00	\$16,000.00	\$1,000.00	6%
Mileage Travel Expense	\$0.00	\$0.00	\$2,000.00	\$2,000.00	100%
Municipal Replacement Tax	\$0.00	\$0.00	\$252,252.00	\$252,252.00	100%
Postage	\$0.00	\$0.00	\$1,000.00	\$1,000.00	100%
Printing Publishing	\$0.00	\$0.00	\$20,500.00	\$20,500.00	100%
Telephone	\$484.53	\$484.53	\$7,500.00	\$7,015.47	94%
Training	\$0.00	\$0.00	\$15,000.00	\$15,000.00	100%
Miscellaneous	\$0.00	\$0.00	\$20,000.00	\$20,000.00	100%
Office Supplies	\$0.00	\$0.00	\$4,500.00	\$4,500.00	100%
Office Equipment	\$0.00	\$0.00	\$10,500.00	\$10,500.00	100%
<b>Total</b>	<b>\$55,066.49</b>	<b>\$55,066.49</b>	<b>\$847,932.00</b>	<b>\$792,865.51</b>	<b>94%</b>

**GENERAL ROAD FUND-MAINTENANCE**

Maint Salary Expense	\$0.00	\$0.00	\$225,000.00	\$225,000.00	100%
Miscellaneous-Uniforms	\$0.00	\$0.00	\$8,000.00	\$8,000.00	100%
Building Maintenance	\$120.30	\$120.30	\$15,500.00	\$15,379.70	99%
Equipment Leasing Maint	\$4,179.91	\$4,179.91	\$78,136.00	\$73,956.09	95%
Landfill Charges - GRF	\$1,027.36	\$1,027.36	\$12,500.00	\$11,472.64	92%
Rentals	\$650.00	\$650.00	\$15,000.00	\$14,350.00	96%
Street Lighting	\$4,783.24	\$4,783.24	\$70,000.00	\$65,216.76	93%
Tree Removal & Spraying	\$6,330.80	\$6,330.80	\$40,000.00	\$33,669.20	84%
Utilities	\$678.34	\$678.34	\$25,000.00	\$24,321.66	97%
Tree Replacement Program		\$0.00	\$15,000.00	\$15,000.00	100%
Gasoline Oil	\$402.99	\$402.99	\$60,000.00	\$59,597.01	99%

## MAINE TOWNSHIP ROAD AND BRIDGE FUND

92% of the year remaining	MAR	YTD EXPENSE	BUDGET	BALANCE	% Left
Building & Oper Sup Matl	\$87.34	\$87.34	\$16,500.00	\$16,412.66	99%
Maint Equip & Small Tools	\$511.50	\$511.50	\$20,000.00	\$19,488.50	97%
Supplies (Equipment)	\$0.00	\$0.00	\$16,500.00	\$16,500.00	100%
Supplies Roads GRF	\$0.00	\$0.00	\$7,200.00	\$7,200.00	100%
Supplies Snow Removal	\$0.00	\$0.00	\$105,000.00	\$105,000.00	100%
<b>Total</b>	<b>\$18,771.78</b>	<b>\$18,771.78</b>	<b>\$729,336.00</b>	<b>\$710,564.22</b>	<b>97%</b>

### PERMANENT ROAD FUND

Labor On Roads	\$35,414.60	\$35,414.60	\$450,000.00	\$414,585.40	92%
Drainage		\$0.00	\$8,000.00	\$8,000.00	100%
Engineering Services	\$3,217.50	\$3,217.50	\$55,000.00	\$51,782.50	94%
Landfill Charges - PRF		\$0.00	\$15,000.00	\$15,000.00	100%
Project Expenses		\$0.00	\$45,000.00	\$45,000.00	100%
Maintenance Roads	\$3,331.17	\$3,331.17	\$1,110,000.00	\$1,106,668.83	100%
Supplies / Roads PRF	\$491.13	\$491.13	\$40,000.00	\$39,508.87	99%
<b>Total</b>	<b>\$42,454.40</b>	<b>\$42,454.40</b>	<b>\$1,723,000.00</b>	<b>\$1,680,545.60</b>	<b>98%</b>

### EQUIPMENT & BUILDING FUND

Equipment	\$16,694.12	\$16,694.12	\$200,000.00	\$183,305.88	92%
Building		\$0.00	\$75,000.00	\$75,000.00	100%
Storage Building	\$1,859.81	\$1,859.81	\$40,000.00	\$38,140.19	95%
<b>Total</b>	<b>\$18,553.93</b>	<b>\$18,553.93</b>	<b>\$315,000.00</b>	<b>\$296,446.07</b>	<b>94%</b>

### SOCIAL SECURITY FUND

Social Security	\$3,061.72	\$3,061.72	\$62,000.00	\$58,938.28	95%
<b>Total</b>	<b>\$3,061.72</b>	<b>\$3,061.72</b>	<b>\$62,000.00</b>	<b>\$58,938.28</b>	<b>95%</b>

### INSURANCE FUND

Workmans Compensation		\$0.00	\$25,000.00	\$25,000.00	100%
Unemployment Insurance		\$0.00	\$535.00	\$535.00	100%
Gen Ins Liability Ins Bond		\$0.00	\$49,000.00	\$49,000.00	100%
<b>Total</b>	<b>\$0.00</b>	<b>\$0.00</b>	<b>\$74,535.00</b>	<b>\$74,535.00</b>	<b>100%</b>

### IL MUNICIPAL RETIREMENT FUND

IMRF	\$2,617.43	\$2,617.43	\$67,400.00	\$64,782.57	96%
IMRF Employer ERI Cost		\$0.00	\$1,000.00	\$1,000.00	100%
<b>Total</b>	<b>\$2,617.43</b>	<b>\$2,617.43</b>	<b>\$68,400.00</b>	<b>\$65,782.57</b>	<b>96%</b>

<b>TOTAL OPERATING EXPENSES</b>	<b>\$140,525.75</b>	<b>\$140,525.75</b>	<b>\$3,820,203.00</b>	<b>\$3,679,677.25</b>	<b>96%</b>

**MOTION TO APPROVE PAYROLL FOR PAYDATES OF MARCH 27,  
2026 APRIL 10, 2026 AND APRIL 24, 2026, ACH/WIRE PAYMENTS  
AND ROAD DISTRICT CHECKS #25796 THROUGH CHECK #25843  
IN THE AMOUNT OF \$152,108.35**

**Maine Township Road and Bridge**

**For the Period From March 25th, 2026 - April 28th, 2026**

<b>Check #</b>	<b>Date</b>	<b>Payee</b>	<b>Description</b>	<b>Amount</b>
<b>S/C</b>	3/27/2026	PAYCHEX	SERVICE FEE	\$357.98
<b>Wire</b>	3/27/2026	FEDERAL ELECTRONIC PAYROLL SYSTEM	FEDERAL TAXES	\$5,730.46
<b>Wire</b>	3/27/2026	ILLINOIS DEPARTMENT OF REVENUE	STATE TAXES	\$994.28
<b>DIR. DEPOSIT</b>	3/27/2026	BRANDES, RICHARD A	PAYROLL	\$3,658.81
<b>DIR. DEPOSIT</b>	3/27/2026	JIMENEZ, PETER A	PAYROLL	\$2,246.88
<b>DIR. DEPOSIT</b>	3/27/2026	MAC INTYRE, JUSTIN E	PAYROLL	\$2,600.63
<b>DIR. DEPOSIT</b>	3/27/2026	PEREZ, JOHNATAN	PAYROLL	\$1,930.78
<b>DIR. DEPOSIT</b>	3/27/2026	WOODS, TYLER J	PAYROLL	\$2,097.23
<b>7005700102</b>	3/27/2026	VIGNA, MARISSA	PAYROLL	\$1,960.52
<b>25796</b>	3/27/2026	SECURITY BENEFIT	SECURITY BENEFITS 457 DEFERRED COMPENSATION 03/27/2026 PAYROLL	\$400.00

Check #	Date	Payee	Description	Amount
25757V	4/2/2026	IMPERIAL HOME DESIGNS	REPRINT - FEBRUARY EXPENSE	-\$24,700.00
25797	4/2/2026	IMPERIAL HOME DESIGNS	REPRINT - FEBRUARY EXPENSE	\$24,700.00
25798	4/2/2026	MATTHYS' GARAGE LLC	REPRINT - FEBRUARY EXPENSE	\$7,937.20
25758V	4/2/2026	MATTHYS' GARAGE LLC	REPRINT - FEBRUARY EXPENSE	-\$7,937.20
25799	4/9/2026	SECURITY BENEFIT	DEFERRED COMPENSATION FOR ROAD DISTRICT 04/10/2026 PAYROLL	\$400.00
S/C	4/10/2026	PAYCHEX	SERVICE FEE	\$401.78
Wire	4/10/2026	FEDERAL ELECTRONIC PAYROLL SYSTEM	FEDERAL TAXES	\$4,745.13
Wire	4/10/2026	ILLINOIS DEPARTMENT OF REVENUE	STATE TAXES	\$863.71
DIR. DEPOSIT	4/10/2026	BRANDES, RICHARD A	PAYROLL	\$2,889.64
DIR. DEPOSIT	4/10/2026	JIMENEZ, PETER A	PAYROLL	\$1,913.77
DIR. DEPOSIT	4/10/2026	MAC INTYRE, JUSTIN E	PAYROLL	\$2,456.17
DIR. DEPOSIT	4/10/2026	PEREZ, JOHNATAN	PAYROLL	\$1,832.42
DIR. DEPOSIT	4/10/2026	WOODS, TYLER J	PAYROLL	\$1,845.12

Check #	Date	Payee	Description	Amount
<b>7005700103</b>	4/10/2026	VIGNA, MARISSA	PAYROLL	\$1,880.54
<b>WIRE</b>	4/14/2026	IMRF	ILLINOIS MUNICIPAL RETIREMENT FUND	\$5,359.58
<b>25800</b>	4/22/2026	VERIZON WIRELESS	SERVICE - 3/4-4/3/26	\$305.42
<b>S/C</b>	4/24/2026	PAYCHEX	SERVICE FEE	\$390.21
<b>Wire</b>	4/24/2026	FEDERAL ELECTRONIC PAYROLL SYSTEM	FEDERAL TAXES	\$5,677.09
<b>Wire</b>	4/24/2026	ILLINOIS DEPARTMENT OF REVENUE	STATE TAXES	\$1,029.00
<b>DIR. DEPOSIT</b>	4/24/2026	BRANDES, RICHARD A	PAYROLL	\$3,138.09
<b>DIR. DEPOSIT</b>	4/24/2026	HOCK, CRISTIN	PAYROLL	\$1,689.09
<b>DIR. DEPOSIT</b>	4/24/2026	JIMENEZ, PETER A	PAYROLL	\$2,042.70
<b>DIR. DEPOSIT</b>	4/24/2026	MAC INTYRE, JUSTIN E	PAYROLL	\$2,809.31
<b>DIR. DEPOSIT</b>	4/24/2026	PEREZ, JOHNATAN	PAYROLL	\$1,781.31
<b>DIR. DEPOSIT</b>	4/24/2026	WOODS, TYLER J	PAYROLL	\$1,966.14
<b>7005700104</b>	4/24/2026	VIGNA, MARISSA	PAYROLL	\$1,880.55
<b>25801</b>	4/28/2026	AT&T	TELEPHONE & COMMUNICATIONS	\$78.52

Check #	Date	Payee	Description	Amount
25802	4/28/2026	ALEXANDER EQUIPMENT CO INC	EQUIPMENT MAINTENANCE	\$1,047.26
25803	4/28/2026	AMERICAN WELDING	EQUIPMENT MAINTENANCE	\$54.31
25804	4/28/2026	BANNER BIOLOGICALS	TREE REMOVAL & SPRAYING	\$539.00
25805	4/28/2026	BEVERLY MATERIALS, L.L.C.	SUPPLIES FOR ROAD - STONE	\$1,814.66
25806	4/28/2026	BLUE CROSS BLUE SHIELD OF IL	ROAD AND BRIDGE BCBSIL MAY 2026 PREMIUM	\$17,290.30
25807	4/28/2026	COMED - GARAGE	SERVICE AT GARAGE - 3/10- 4/9/26	\$664.81
25808	4/28/2026	COMED - STREET LIGHTING	STREET LIGHTING - 2/17- 3/18/26	\$4,131.65
25809	4/28/2026	COMED - TRAFFIC SIGNALS	TRAFFIC SIGNALS - 2/25- 3/26/26	\$51.21
25810	4/28/2026	CONSERV FS, INC.	FUEL	\$2,060.15
25811	4/28/2026	CRISTIN HOCK	HEALTH INSURANCE BONUS	\$3,000.00
25812	4/28/2026	DAMIANO DIESEL SERVICE	REPAIR TO CHIPPER	\$943.88
25813	4/28/2026	CITY OF DES PLAINES	UTILITIES	\$227.48

Check #	Date	Payee	Description	Amount
25814	4/28/2026	DES PLAINES MATERIAL & SUPPLY	SUPPLIES/ROADS	\$738.81
25815	4/28/2026	DOMESTIC UNIFORM RENTAL	UNIFORMS	\$120.30
25816	4/28/2026	GROOT INDUSTRIES, INC.	LANDFILL	\$201.00
25817	4/28/2026	GRAINGER INC	BUILDING OPERATING SUPPLIES	\$161.58
25818	4/28/2026	CAPITAL ONE TRADE CREDIT	SUPPLIES - EQUIPMENT	\$740.01
25819	4/28/2026	HOME DEPOT CREDIT SERVICES	SMALL TOOLS & EQUIPMENT	\$344.17
25820	4/28/2026	JIMENEZ, PETER	TELEPHONE & COMMUNICATIONS (MONTHLY STIPEND)	\$25.00
25821	4/28/2026	M3 MARKETING LLC	COMMUNITY OUTREACH - APR 26	\$2,000.00
25822	4/28/2026	MACMUNNIS INC AAF COM ED	OFFSITE STORAGE - COMED & PARKING TAX - 5/1/26	\$1,859.81
25823	4/28/2026	MACINTYRE, JUSTIN	TELEPHONE & COMMUNICATIONS (MONTHLY STIPEND)	\$25.00
25824	4/28/2026	METRO FEDERAL CREDIT UNION	EXPENSES	\$1,941.81
25825	4/28/2026	METRO FEDERAL CREDIT UNION	EXPENSES	\$22.63

Check #	Date	Payee	Description	Amount
25826	4/28/2026	NAPA AUTO PARTS	EQUIPMENT MAINTENANCE	\$106.88
25827	4/28/2026	NICOR GAS	SERVICE -3/17-4/15/26	\$488.03
25828	4/28/2026	PARK RIDGE CHAMBER OF COMMERCE	2026 DUES	\$5,000.00
25829	4/28/2026	PEREZ, JOHNATAN	TELEPHONE & COMMUNICATIONS (MONTHLY STIPEND)	\$25.00
25830	4/28/2026	PESCHES FLOWER SHOP	TREE REPLACEMENT PROGRAM	\$8,889.70
25831	4/28/2026	PRINCIPAL	MAY PREMIUMS	\$819.12
25832	4/28/2026	RUSSO'S POWER EQUIPMENT, INC.	EQUIPMENT MAINTENANCE	\$477.24
25833	4/28/2026	SPACECO, INC.	ENGINEERING SERVICES	\$8,457.50
25834	4/28/2026	THE MULCH CENTER	TREE REMOVAL/SPRAYING	\$200.00
25835	4/28/2026	TYLER WOODS	TELEPHONE & COMMUNICATIONS (MONTHLY STIPEND)	\$25.00
25836	4/28/2026	USSI RENTALS, INC.	BUILDING OPERATING SUPPLIES	\$4,110.12
25837	4/28/2026	ZEP SALES AND SERVICE	BUILDING MAINTENANCE	\$4,076.47

Check #	Date	Payee	Description	Amount
25838	4/28/2026	CITY OF DES PLAINES	4TH OF JULY PARADE	\$50.00
25839	4/28/2026	DP CHAMBER OF COMMERCE	DUES AND SUBSCRIPTIONS	\$2,200.00
25840	4/28/2026	DES PLAINES PARK DISTRICT	DUES AND SUBSCRIPTIONS	\$2,000.00
25841	4/28/2026	GOLF MILL FORD	EQUIPMENT MAINTENANCE	\$264.23
25842	4/28/2026	NILES CHAMBER OF COMMERCE	DUES AND SUBSCRIPTIONS	\$5,000.00
25843	4/28/2026	ULINE	BUILDING MAINTENANCE	\$561.37
				<b>\$152,108.35</b>

We the undersigned members of the Board of Trustees of Maine Township, do hereby certify that we have examined the Payroll for March 27, 2026, April 10, 2026 and April 24, 2026, ACH/Wire Payments and Road District Checks #25796 through Check #25843 and authorize the Supervisor to issue Checks in payment of \$152,108.35

WITNESS OUR HANDS AND SEALS THIS 28TH DAY OF APRIL, 2026

\_\_\_\_\_  
Supervisor

\_\_\_\_\_

Attest:

\_\_\_\_\_

\_\_\_\_\_  
Clerk

\_\_\_\_\_

\_\_\_\_\_  
Trustees

**MOTION TO APPROVE PAYROLL FOR PAYDATES OF MARCH  
27, 2026 APRIL 10, 2026 AND APRIL 24, 2026, ACH/WIRE  
PAYMENTS AND TOWN FUND CHECKS #63424 THROUGH  
CHECK #63491 IN THE AMOUNT OF \$360,166.06**

**Maine Township Town Fund**

**For the Period From March 25th, 2026 - April 28th, 2026**

<b>Check #</b>	<b>Date</b>	<b>Payee</b>	<b>Description</b>	<b>Amount</b>
<b>DIRECT DEPOSIT</b>	3/26/2026	PAYCHEX	FLEXPERKS	<b>\$ 128.99</b>
<b>63424</b>	3/27/2026	SECURITY BENEFIT	SECURITY BENEFIT FOR TOWN FUND 03/27/2026 PAYROLL	<b>\$ 975.00</b>
<b>7002800104</b>	3/27/2026	MOYLAN KREY, SUSAN	PAYROLL	<b>\$ 945.47</b>
<b>ACH</b>	3/27/2026	FEDERAL ELECTRONIC PAYROLL SYSTEM	FEDERAL TAXES	<b>\$ 15,222.98</b>
<b>ACH</b>	3/27/2026	ILLINOIS DEPARTMENT OF REVENUE	STATE TAXES	<b>\$ 3,025.92</b>
<b>ACH</b>	3/27/2026	PAYCHEX	SERVICE FEE	<b>\$ 921.14</b>
<b>DIRECT DEPOSIT</b>	3/27/2026	JONES, KIMBERLY	PAYROLL	<b>\$ 1,127.06</b>
<b>DIRECT DEPOSIT</b>	3/27/2026	GIALAMAS, PETER W	PAYROLL	<b>\$ 371.41</b>
<b>DIRECT DEPOSIT</b>	3/27/2026	AL AYED, RUBA	PAYROLL	<b>\$ 1,701.12</b>
<b>DIRECT DEPOSIT</b>	3/27/2026	CARROZZA, ROBERT	PAYROLL	<b>\$ 77.32</b>
<b>DIRECT DEPOSIT</b>	3/27/2026	COOK, MARTY	PAYROLL	<b>\$ 592.83</b>
<b>DIRECT DEPOSIT</b>	3/27/2026	CUSTIC, ELIO	PAYROLL	<b>\$ 357.19</b>

<b>Check #</b>	<b>Date</b>	<b>Payee</b>	<b>Description</b>	<b>Amount</b>
<b>DIRECT DEPOSIT</b>	3/27/2026	DEBOWCZYK, IZABELA	PAYROLL	\$ 1,149.24
<b>DIRECT DEPOSIT</b>	3/27/2026	DOHERTY, JAMES	PAYROLL	\$ 748.61
<b>DIRECT DEPOSIT</b>	3/27/2026	GHAZALEH SR, NADER A	PAYROLL	\$ 1,554.86
<b>DIRECT DEPOSIT</b>	3/27/2026	KEDZIOR, WESLEY	PAYROLL	\$ 258.15
<b>DIRECT DEPOSIT</b>	3/27/2026	REZUTKO-CUSTIC, PAULA	PAYROLL	\$ 907.96
<b>DIRECT DEPOSIT</b>	3/27/2026	RIZZO, VICTORIA K	PAYROLL	\$ 3,297.93
<b>DIRECT DEPOSIT</b>	3/27/2026	SAMAAN, MICHAEL A	PAYROLL	\$ 1,822.85
<b>DIRECT DEPOSIT</b>	3/27/2026	WAITE, DAVID	PAYROLL	\$ 699.20
<b>DIRECT DEPOSIT</b>	3/27/2026	WOLF, JONATHAN	PAYROLL	\$ 1,187.96
<b>DIRECT DEPOSIT</b>	3/27/2026	BABICH, DEBRA A	PAYROLL	\$ 1,715.54
<b>DIRECT DEPOSIT</b>	3/27/2026	COY, ELIZABETH J	PAYROLL	\$ 1,454.74
<b>DIRECT DEPOSIT</b>	3/27/2026	DABABNEH, FARIS E	PAYROLL	\$ 1,392.85
<b>DIRECT DEPOSIT</b>	3/27/2026	PHILLIPS, MARY DOLORES	PAYROLL	\$ 751.73
<b>DIRECT DEPOSIT</b>	3/27/2026	PLODZIEN, RICHARD	PAYROLL	\$ 504.86
<b>DIRECT DEPOSIT</b>	3/27/2026	CALLAHAN, ERIN C	PAYROLL	\$ 1,636.05
<b>DIRECT DEPOSIT</b>	3/27/2026	KALVELAGE, ARIELLE S	PAYROLL	\$ 1,762.47

Check #	Date	Payee	Description	Amount
DIRECT DEPOSIT	3/27/2026	LYON, RICHARD D	PAYROLL	\$ 2,662.16
DIRECT DEPOSIT	3/27/2026	PARKER, IAIN	PAYROLL	\$ 1,422.30
DIRECT DEPOSIT	3/27/2026	TOOMEY, EMILY	PAYROLL	\$ 1,244.75
DIRECT DEPOSIT	3/27/2026	ZUMBROCK, SUMMER	PAYROLL	\$ 1,736.13
DIRECT DEPOSIT	3/27/2026	BUKACZYK, OKSANA T	PAYROLL	\$ 1,530.65
DIRECT DEPOSIT	3/27/2026	DACHNIWSKY, MARIE C	PAYROLL	\$ 1,757.24
DIRECT DEPOSIT	3/27/2026	JAROSZEWICZ, MONIKA	PAYROLL	\$ 1,714.34
DIRECT DEPOSIT	3/27/2026	TULLY, THERESE A	PAYROLL	\$ 1,923.61
DIRECT DEPOSIT	3/27/2026	GUZMAN, JESSICA I	PAYROLL	\$ 1,345.06
DIRECT DEPOSIT	3/27/2026	MAGNOWSKI, EVA	PAYROLL	\$ 1,807.46
DIRECT DEPOSIT	3/27/2026	RYDER, CATHLEEN	PAYROLL	\$ 736.24
DIRECT DEPOSIT	3/27/2026	GRABOWSKI, GERARD	PAYROLL	\$ 34.96
DIRECT DEPOSIT	3/27/2026	LECHOWICZ, ANDREW	PAYROLL	\$ 43.69
DIRECT DEPOSIT	3/27/2026	LORKIEWICZ, MICHAEL	PAYROLL	\$ 41.18
DIRECT DEPOSIT	3/27/2026	WISNIEWSKI, JACK	PAYROLL	\$ 767.42
63425	4/1/2026	CITY OF DES PLAINES PHOTO ENFORCEMENT P	PACE EXPENSE	\$ 100.00

Check #	Date	Payee	Description	Amount
63426	4/1/2026	COMCAST	SERVICE AT TOWN HALL	\$ 372.13
63427	4/1/2026	ORKIN	PEST CONTROL	\$ 97.63
S/C	4/3/2026	ELS SERVICE FEE	LICENSE PLACE SERVICE FEE	\$ 30.40
63428	4/2/2026	PROCOM ENTERPRISES LTD	MONITORING	\$ 207.00
SC	4/3/2026	THERAPY NOTES	SERVICE FEE	\$ 66.77
63429	4/8/2026	SECURITY BENEFIT	PAYROLL CONTRIBUTION	\$ 975.00
63430	4/8/2026	VERIZON WIRELESS-ADMIN	MONTHLY FEE	\$ 78.74
63431	4/9/2026	ACCESS ONE, INC	POTS LINES APRIL	\$ 161.05
63432	4/9/2026	VERIZON WIRELESS-ADMIN	MONTHLY FEE	\$ 191.71
WIRE	4/9/2026	IMRF	ILLINOIS MUNICIPAL RETIREMENT FUND	\$ 17,105.11
DIRECT DEPOSIT	4/9/2026	PAYCHEX	FLEXPERKS	\$ 143.99
7002800105	4/10/2026	MOYLAN KREY, SUSAN	PAYROLL	\$ 945.48
ACH	4/10/2026	FEDERAL ELECTRONIC PAYROLL SYSTEM	FEDERAL TAXES	\$ 17,109.20
ACH	4/10/2026	ILLINOIS DEPARTMENT OF REVENUE	STATE TAXES	\$ 3,361.76
ACH	4/10/2026	PAYCHEX	SERVICE FEE	\$ 997.41
DIRECT DEPOSIT	4/10/2026	JONES, KIMBERLY	PAYROLL	\$ 1,127.07
DIRECT DEPOSIT	4/10/2026	GIALAMAS, PETER W	PAYROLL	\$ 371.40

<b>Check #</b>	<b>Date</b>	<b>Payee</b>	<b>Description</b>	<b>Amount</b>
<b>DIRECT DEPOSIT</b>	4/10/2026	BEAUVAIS, EDWARD	PAYROLL	\$ 3,656.56
<b>DIRECT DEPOSIT</b>	4/10/2026	LYNCH, ELIZABETH	PAYROLL	\$ 580.64
<b>DIRECT DEPOSIT</b>	4/10/2026	MAHER, JAMES	PAYROLL	\$ 367.93
<b>DIRECT DEPOSIT</b>	4/10/2026	MALIK, ASIF	PAYROLL	\$ 580.64
<b>DIRECT DEPOSIT</b>	4/10/2026	MARON HORVATH, KELLY	PAYROLL	\$ 613.52
<b>DIRECT DEPOSIT</b>	4/10/2026	AL AYED, RUBA	PAYROLL	\$ 1,701.11
<b>DIRECT DEPOSIT</b>	4/10/2026	CARROZZA, ROBERT	PAYROLL	\$ 146.68
<b>DIRECT DEPOSIT</b>	4/10/2026	COOK, MARTY	PAYROLL	\$ 1,011.38
<b>DIRECT DEPOSIT</b>	4/10/2026	CUSTIC, ELIO	PAYROLL	\$ 426.72
<b>DIRECT DEPOSIT</b>	4/10/2026	DEBOWCZYK, IZABELA	PAYROLL	\$ 539.24
<b>DIRECT DEPOSIT</b>	4/10/2026	DOHERTY, JAMES	PAYROLL	\$ 694.42
<b>DIRECT DEPOSIT</b>	4/10/2026	GHAZALEH SR, NADER A	PAYROLL	\$ 1,534.10
<b>DIRECT DEPOSIT</b>	4/10/2026	KEDZIOR, WESLEY	PAYROLL	\$ 325.02
<b>DIRECT DEPOSIT</b>	4/10/2026	REZUTKO-CUSTIC, PAULA	PAYROLL	\$ 930.24
<b>DIRECT DEPOSIT</b>	4/10/2026	RIZZO, VICTORIA K	PAYROLL	\$ 3,297.93
<b>DIRECT DEPOSIT</b>	4/10/2026	SAMAAN, MICHAEL A	PAYROLL	\$ 2,742.04

<b>Check #</b>	<b>Date</b>	<b>Payee</b>	<b>Description</b>	<b>Amount</b>
<b>DIRECT DEPOSIT</b>	4/10/2026	WAITE, DAVID	PAYROLL	\$ 611.80
<b>DIRECT DEPOSIT</b>	4/10/2026	WOLF, JONATHAN	PAYROLL	\$ 1,184.39
<b>DIRECT DEPOSIT</b>	4/10/2026	BABICH, DEBRA A	PAYROLL	\$ 1,715.53
<b>DIRECT DEPOSIT</b>	4/10/2026	COY, ELIZABETH J	PAYROLL	\$ 1,454.72
<b>DIRECT DEPOSIT</b>	4/10/2026	DABABNEH, FARIS E	PAYROLL	\$ 1,392.87
<b>DIRECT DEPOSIT</b>	4/10/2026	PHILLIPS, MARY DOLORES	PAYROLL	\$ 813.08
<b>DIRECT DEPOSIT</b>	4/10/2026	PLODZIEN, RICHARD	PAYROLL	\$ 605.48
<b>DIRECT DEPOSIT</b>	4/10/2026	CALLAHAN, ERIN C	PAYROLL	\$ 1,636.05
<b>DIRECT DEPOSIT</b>	4/10/2026	KALVELAGE, ARIELLE S	PAYROLL	\$ 1,762.47
<b>DIRECT DEPOSIT</b>	4/10/2026	LYON, RICHARD D	PAYROLL	\$ 2,662.15
<b>DIRECT DEPOSIT</b>	4/10/2026	PARKER, IAIN	PAYROLL	\$ 1,422.31
<b>DIRECT DEPOSIT</b>	4/10/2026	TOOMEY, EMILY	PAYROLL	\$ 1,229.75
<b>DIRECT DEPOSIT</b>	4/10/2026	ZUMBROCK, SUMMER	PAYROLL	\$ 1,736.12
<b>DIRECT DEPOSIT</b>	4/10/2026	BUKACZYK, OKSANA T	PAYROLL	\$ 1,530.66
<b>DIRECT DEPOSIT</b>	4/10/2026	DACHNIWSKY, MARIE C	PAYROLL	\$ 1,757.24
<b>DIRECT DEPOSIT</b>	4/10/2026	JAROSZEWICZ, MONIKA	PAYROLL	\$ 1,714.32

Check #	Date	Payee	Description	Amount
<b>DIRECT DEPOSIT</b>	4/10/2026	TULLY, THERESE A	PAYROLL	\$ 1,923.62
<b>DIRECT DEPOSIT</b>	4/10/2026	GUZMAN, JESSICA I	PAYROLL	\$ 1,345.07
<b>DIRECT DEPOSIT</b>	4/10/2026	MAGNOWSKI, EVA	PAYROLL	\$ 1,807.46
<b>DIRECT DEPOSIT</b>	4/10/2026	RYDER, CATHLEEN	PAYROLL	\$ 635.28
<b>DIRECT DEPOSIT</b>	4/10/2026	LECHOWICZ, ANDREW	PAYROLL	\$ 52.44
<b>DIRECT DEPOSIT</b>	4/10/2026	LORKIEWICZ, MICHAEL	PAYROLL	\$ 54.29
<b>DIRECT DEPOSIT</b>	4/10/2026	WISNIEWSKI, JACK	PAYROLL	\$ 860.40
<b>63433</b>	4/13/2026	COMCAST BUSINESS	SERVICE AT TOWN HALL	\$ 1,055.08
<b>63434</b>	4/13/2026	DOMINIK BRONAKOWSKI	ATM MODERATOR FEE	\$ 75.00
<b>7002800106</b>	4/24/2026	MOYLAN KREY, SUSAN	PAYROLL	\$ 945.46
<b>ACH</b>	4/24/2026	FEDERAL ELECTRONIC PAYROLL SYSTEM	FEDERAL TAXES	\$ 15,218.97
<b>ACH</b>	4/24/2026	ILLINOIS DEPARTMENT OF REVENUE	STATE TAXES	\$ 3,027.40
<b>ACH</b>	4/24/2026	PAYCHEX	SERVICE FEE	\$ 991.69
<b>DIRECT DEPOSIT</b>	4/23/2026	PAYCHEX	FLEXPERKS	\$ 470.98
<b>DIRECT DEPOSIT</b>	4/24/2026	JONES, KIMBERLY	PAYROLL	\$ 1,127.07
<b>DIRECT DEPOSIT</b>	4/24/2026	GIALAMAS, PETER W	PAYROLL	\$ 371.41

Check #	Date	Payee	Description	Amount
DIRECT DEPOSIT	4/24/2026	AL AYED, RUBA	PAYROLL	\$ 1,701.12
DIRECT DEPOSIT	4/24/2026	CARROZZA, ROBERT	PAYROLL	\$ 131.01
DIRECT DEPOSIT	4/24/2026	COOK, MARTY	PAYROLL	\$ 1,011.38
DIRECT DEPOSIT	4/24/2026	CUSTIC, ELIO	PAYROLL	\$ 386.06
DIRECT DEPOSIT	4/24/2026	DOHERTY, JAMES	PAYROLL	\$ 675.08
DIRECT DEPOSIT	4/24/2026	GHAZALEH SR, NADER A	PAYROLL	\$ 1,501.82
DIRECT DEPOSIT	4/24/2026	KEDZIOR, WESLEY	PAYROLL	\$ 313.88
DIRECT DEPOSIT	4/24/2026	REZUTKO-CUSTIC, PAULA	PAYROLL	\$ 964.38
DIRECT DEPOSIT	4/24/2026	RIZZO, VICTORIA K	PAYROLL	\$ 3,297.93
DIRECT DEPOSIT	4/24/2026	SAMAAN, MICHAEL A	PAYROLL	\$ 2,129.25
DIRECT DEPOSIT	4/24/2026	SISSMAN, LAURA	PAYROLL	\$ 319.67
DIRECT DEPOSIT	4/24/2026	WAITE, DAVID	PAYROLL	\$ 493.80
DIRECT DEPOSIT	4/24/2026	WOLF, JONATHAN	PAYROLL	\$ 1,205.88
DIRECT DEPOSIT	4/24/2026	BABICH, DEBRA A	PAYROLL	\$ 1,715.53
DIRECT DEPOSIT	4/24/2026	COY, ELIZABETH J	PAYROLL	\$ 1,454.74
DIRECT DEPOSIT	4/24/2026	DABABNEH, FARIS E	PAYROLL	\$ 1,392.85

<b>Check #</b>	<b>Date</b>	<b>Payee</b>	<b>Description</b>	<b>Amount</b>
<b>DIRECT DEPOSIT</b>	4/24/2026	PHILLIPS, MARY DOLORES	PAYROLL	\$ 751.73
<b>DIRECT DEPOSIT</b>	4/24/2026	PLODZIEN, RICHARD	PAYROLL	\$ 423.59
<b>DIRECT DEPOSIT</b>	4/24/2026	CALLAHAN, ERIN C	PAYROLL	\$ 1,636.05
<b>DIRECT DEPOSIT</b>	4/24/2026	KALVELAGE, ARIELLE S	PAYROLL	\$ 1,762.47
<b>DIRECT DEPOSIT</b>	4/24/2026	LYON, RICHARD D	PAYROLL	\$ 2,662.16
<b>DIRECT DEPOSIT</b>	4/24/2026	PARKER, IAIN	PAYROLL	\$ 1,422.29
<b>DIRECT DEPOSIT</b>	4/24/2026	TOOMEY, EMILY	PAYROLL	\$ 902.76
<b>DIRECT DEPOSIT</b>	4/24/2026	ZUMBROCK, SUMMER	PAYROLL	\$ 1,736.13
<b>DIRECT DEPOSIT</b>	4/24/2026	BUKACZYK, OKSANA T	PAYROLL	\$ 1,530.65
<b>DIRECT DEPOSIT</b>	4/24/2026	DACHNIWSKY, MARIE C	PAYROLL	\$ 1,757.24
<b>DIRECT DEPOSIT</b>	4/24/2026	JAROSZEWICZ, MONIKA	PAYROLL	\$ 1,714.33
<b>DIRECT DEPOSIT</b>	4/24/2026	TULLY, THERESE A	PAYROLL	\$ 1,923.62
<b>DIRECT DEPOSIT</b>	4/24/2026	GUZMAN, JESSICA I	PAYROLL	\$ 1,345.06
<b>DIRECT DEPOSIT</b>	4/24/2026	ISMAIL, DENA	PAYROLL	\$ 370.90
<b>DIRECT DEPOSIT</b>	4/24/2026	MAGNOWSKI, EVA	PAYROLL	\$ 1,807.47
<b>DIRECT DEPOSIT</b>	4/24/2026	RYDER, CATHLEEN	PAYROLL	\$ 659.32

Check #	Date	Payee	Description	Amount
<b>DIRECT DEPOSIT</b>	4/24/2026	GRABOWSKI, GERARD	PAYROLL	\$ 104.88
<b>DIRECT DEPOSIT</b>	4/24/2026	LECHOWICZ, ANDREW	PAYROLL	\$ 179.17
<b>DIRECT DEPOSIT</b>	4/24/2026	WISNIEWSKI, JACK	PAYROLL	\$ 870.13
<b>63435</b>	4/28/2026	AMANDA DEE	RECOVERY CONNECTION FLYERS	\$ 550.00
<b>63436</b>	4/28/2026	AMERICAN TAXI DISPATCH, INC.	19 MAINELINES VOUCHERS	\$ 95.00
<b>63437</b>	4/28/2026	ANCEL GLINK P.C.	LEGAL SERVICES	\$ 9,400.00
<b>63438</b>	4/28/2026	AQUA ILLINOIS, INC	WATER SERVICE AT TOWN HALL	\$ 203.34
<b>63439</b>	4/28/2026	AVENUES TO INDEPENDENCE	GRANT PAYMENT	\$ 4,683.00
<b>63440</b>	4/28/2026	BLUE CROSS BLUE SHIELD	MAY PREMIUMS	\$ 49,630.96
<b>63441</b>	4/28/2026	BROWN INDUSTRIES, INC.	ANNIVERSARY PINS	\$ 60.91
<b>63442</b>	4/28/2026	THE CENTER OF CONCERN	GRANT PAYMENT	\$ 4,200.00
<b>63443</b>	4/28/2026	COMED	ELECTRIC SERVICE AT TOWN HALL	\$ 1,702.23
<b>63444</b>	4/28/2026	COMED	ELECTRIC SERVICE AT OEM	\$ 191.28
<b>63445</b>	4/28/2026	COOK COUNTY SHERIFF'S	HIREBACK PROGRAM	\$ 2,400.00
<b>63446</b>	4/28/2026	DENISE JAKO	BOOKKEEPING - TEMP	\$ 1,380.00
<b>63447</b>	4/28/2026	DP CHAMBER OF COMM & IND	DUES	\$ 395.00

Check #	Date	Payee	Description	Amount
63448	4/28/2026	DISTRICT 63 EDUCATION	GRANT PAYMENT	\$ 2,025.00
63449	4/28/2026	EVANS, MARSHALL AND PEASE, PC	BOOKKEEPING SERVICES	\$ 5,750.00
63450	4/28/2026	FOX VALLEY FIRE & SAFETY INC.	FIRE ALARM MONITORING	\$ 426.00
63451	4/28/2026	GARVEY'S OFFICE PRODUCTS	OFFICE SUPPLIES	\$ 688.63
63452	4/28/2026	IMAGETEC LP	TONER AND MONTHLY SERVICE	\$ 2,693.40
63453	4/28/2026	VOID		
63454	4/28/2026	IZABELA DEBOWCZYK	MILEAGE	\$ 8.90
63455	4/28/2026	J&P EXTERIORS 1 INC	CHIMNEY AND FLUE WORK	\$ 1,000.00
63456	4/28/2026	JONATHAN LEE-REY	IMPROV INSTRUCTOR	\$ 599.00
63457	4/28/2026	THE JOSSELYN CENTER, NFP	GRANT PAYMENT	\$ 5,608.00
63458	4/28/2026	JOURNAL & TOPICS NEWSPAPERS	LEGAL ADS AND ADS	\$ 661.69
63459	4/28/2026	NICHOLAS KANEHL	RECOVERY CONNECTION FEE	\$ 1,250.00
63460	4/28/2026	KINGSWAY KOURT LLC	RECOVERY CONNECTION	\$ 2,400.00
63461	4/28/2026	LEYDEN FAMILY SERVICE &	GRANT PAYMENT	\$ 5,133.00
63462	4/28/2026	M3 MARKETING, LLC	MONTHLY FEE	\$ 3,450.00
63463	4/28/2026	METRO FEDERAL CREDIT UNION	EXPENSES	\$ 7,411.12
63464	4/28/2026	METRO FEDERAL CREDIT UNION	EXPENSES	\$ 539.95

<b>Check #</b>	<b>Date</b>	<b>Payee</b>	<b>Description</b>	<b>Amount</b>
<b>63465</b>	4/28/2026	METRO FEDERAL CREDIT UNION	EXPENSES	\$ <b>25.45</b>
<b>63466</b>	4/28/2026	METRO FEDERAL CREDIT UNION	EXPENSES	\$ <b>3,626.18</b>
<b>63467</b>	4/28/2026	METRO FEDERAL CREDIT UNION	EXPENSES	\$ <b>358.65</b>
<b>63468</b>	4/28/2026	METRO FEDERAL CREDIT UNION	EXPENSES	\$ <b>2,807.48</b>
<b>63469</b>	4/28/2026	NANCY S. HOROWITZ	TUTORING	\$ <b>280.00</b>
<b>63470</b>	4/28/2026	NCPERS GROUP LIFE INS.	PREMIUMS	\$ <b>64.00</b>
<b>63471</b>	4/28/2026	QUADIENT FINANCE USA, INC	POSTAGE	\$ <b>849.20</b>
<b>63472</b>	4/28/2026	NICOR GAS	SERVICE AT TOWN HALL	\$ <b>847.22</b>
<b>63473</b>	4/28/2026	NICOR GAS	SERVICE AT OEM	\$ <b>323.08</b>
<b>63474</b>	4/28/2026	NIVEEN ALSHEIKH	TUTORING	\$ <b>240.00</b>
<b>63475</b>	4/28/2026	ORKIN	PEST CONTROL	\$ <b>99.41</b>
<b>63476</b>	4/28/2026	OTIS ELEVATOR COMPANY	SERVICE ON ELVEATOR	\$ <b>2,887.40</b>
<b>63477</b>	4/28/2026	PACE SUBURBAN BUS	MONTHLY FEE	\$ <b>100.00</b>
<b>63478</b>	4/28/2026	PARK RIDGE CITY OF	ELEVATOR FEE	\$ <b>60.00</b>
<b>63479</b>	4/28/2026	PESCHE'S INC	ARRANGEMENTS	\$ <b>149.98</b>
<b>63480</b>	4/28/2026	PRINCIPAL LIFE INS. CO.	PREMIUMS	\$ <b>2,373.07</b>
<b>63481</b>	4/28/2026	VOID		
<b>63482</b>	4/28/2026	VOID		

Check #	Date	Payee	Description	Amount
63483	4/28/2026	VOID		
63484	4/28/2026	VOID		
63485	4/28/2026	REVIZE LLC	WEBSITE	\$ 1,975.00
63486	4/28/2026	SKLENA ELECTRIC INC	ELECTRIC WORK	\$ 490.00
63487	4/28/2026	STELLAR EXPRESSIONS LLC	TRANSLATION SERVICE	\$ 18.00
63488	4/28/2026	TOWNSHIP SUPERVISORS OF ILLINOIS	DUES	\$ 30.00
63489	4/28/2026	TURNING POINT BEHAVIORAL	GRANT PAYMENT	\$ 3,875.00
63490	4/28/2026	WAREHOUSE DIRECT	WATERCOOLER RENTAL	\$ 157.00
63491	4/28/2026	ZACHARY CRONISTER	RECOVERY CONNECTION	\$ 900.00
				\$ 360,166.06

We the undersigned members of the Board of Trustees of Maine Township, do hereby certify that we have examined the Payroll for Paydates of March 27, 2026, April 10, 2026 and April 24, 2026 , ACH/Wire Payments, and General Town Fund Checks #63424 through Check #63491 and authorize the Supervisor to issue checks in payment of \$360,166.06

WITNESS OUR HANDS AND SEALS THIS 28th DAY OF APRIL, 2026

\_\_\_\_\_  
Supervisor

Attest:

\_\_\_\_\_  
Clerk

\_\_\_\_\_  
Trustees



# Memo

**To:** Maine Township Elected Officials

**From:** MaineStay Director Richard Lyon

**Date:** March 18, 2026

## Clinical Observation and Recording System Improvements

I am requesting approval of the attached Intelligent Video Solutions proposal to replace the aging equipment we use for video recording of counseling sessions. Our current equipment is 14 years old and in need of replacement due to poor audio and video quality as well as security risks of using old proprietary software required to view the videos.

We utilize video recordings of client sessions (with permission) to facilitate supervision and post-session review for master's level intern therapists selected for our internship training program, as well as for employee therapists needing session recordings for advanced credentialing purposes. It is a requirement of the graduate school programs with whom we work that students be able to video record their sessions for supervision and training purposes. In recent years, employees have also been using recordings to meet requirements for more advanced certifications such as Play Therapy or EMDR.

MaineStay has been providing high-quality training to counseling students for nearly 50 years. These two intern therapists, each here for 10+ months each year and for 20+ hours each week, provide the equivalent amount of service as one full-time clinician at no cost to the township. Replacing our outdated equipment will enhance our ability to provide supervision, support, and advanced training opportunities, while continuing to provide cost-effective delivery of counseling services to our residents.

Thank you for your consideration of my request.

Due March 18, 2026



# Request for Proposal Clinical Observation and Recording System

PREPARED FOR: MAINE TOWNSHIP  
BY: INTELLIGENT VIDEO SOLUTIONS (IVS)

PRIMARY IVS CONTACT:

Josh Riebe, Regional Director

Email: [jriebe@ipivs.com](mailto:jriebe@ipivs.com)

Cell: 321-446-0395

N53W24747 S CORPORATE CIR

SUSSEX, WI 53089

## Contents

1. Minimum Qualifications.....	4
i. Vendor is to provide proof that they are complaint with the Cook County Prevailing Wage Act 820 ILCS 130/4 .....	4
ii. Vendor must submit certificate of insurance naming Maine Township as an additional insured at the award of the contract .....	6
iii. Vendor must provide subcontractor information and proof that work performed by the subcontractor is covered by vendor insurance .....	8
iv. If awarded the work by the Township Board, the Vendor must execute a contract with the Township for the work. The Contract will be on a form acceptable to the Township. ....	8
2. Company Description.....	12
3. References.....	13
i. References should include name of the company, contact info and brief description of services rendered.....	13
4. Subcontractors .....	13
i. Vendor should list any subcontractor’s name, address and state of incorporation that are proposed to be used on the project .....	13
ii. Indicate the subcontractor’s role and responsibilities in the project .....	13
iii. Provide proof of insurance naming Maine Township as the insured at the award of the contract	13
5. Scope of Services.....	14
i. Executive Summary.....	14
ii. Project and Installation Plan .....	14
IVS Responsibilities.....	15
Maine Township Responsibilities .....	17
iii. Project Team .....	19
iv. Product Information.....	20
53011 VALT1E.....	20
10149 T1A2S-K.....	30
90090 SSA.....	22
19033 P3275-K.....	32
39003 WAMIC-K.....	34
39006 STDA3-K.....	35

54007 VALTBPS-K .....	36
39060 ORAS-K .....	37
BEAM (VALT1E license configured on an iOS device).....	38
v. Diagram of Design.....	40
vi. Equipment Listing.....	41
vii. Permits .....	41
viii. Training .....	41
ix. Service Call Information .....	41
x. Warranty .....	43
6. Pricing.....	46
i. Specify all expenses in the estimation of cost .....	46
ii. Describe the scope of services it entails and any services which would not be covered or which would be provided for an additional charge.....	46
iii. Itemized list of cost for project including all hardware, software, software subscriptions, installation fee, shipping, vehicle charge and any other costs associated with project .....	46
iv. Warranty and additional warranty options.....	46
v. Service Calls .....	46

## 1. Minimum Qualifications

- i. **Vendor is to provide proof that they are compliant with the Cook County Prevailing Wage Act 820 ILCS 130/4**

Please see attestation on the next page.

*Remainder of page intentionally left blank*

March 2, 2026

Maine Township  
1700 Ballard Road  
Park Ridge, IL 60068

Re: Prevailing Wage – Cook County, IL

To Whom it Concerns:

Intelligent Video Solutions hereby affirms its full compliance with all applicable prevailing wage requirements at the Federal, State, and County levels, as set forth in the project contract documents provided by the customer at the time of receipt and award.

Please feel free to reach out if you have questions or need additional documentation.

Sincerely,



Holly Knoeck,  
Human Resource Manager

- ii. Vendor must submit certificate of insurance naming Maine Township as an additional insured at the award of the contract**

Please see COI naming Maine Township as an additional insured on the next page.

*Remainder of page intentionally left blank*



# CERTIFICATE OF LIABILITY INSURANCE

DATE (MM/DD/YYYY)

3/2/2026

THIS CERTIFICATE IS ISSUED AS A MATTER OF INFORMATION ONLY AND CONFERS NO RIGHTS UPON THE CERTIFICATE HOLDER. THIS CERTIFICATE DOES NOT AFFIRMATIVELY OR NEGATIVELY AMEND, EXTEND OR ALTER THE COVERAGE AFFORDED BY THE POLICIES BELOW. THIS CERTIFICATE OF INSURANCE DOES NOT CONSTITUTE A CONTRACT BETWEEN THE ISSUING INSURER(S), AUTHORIZED REPRESENTATIVE OR PRODUCER, AND THE CERTIFICATE HOLDER.

**IMPORTANT:** If the certificate holder is an ADDITIONAL INSURED, the policy(ies) must have ADDITIONAL INSURED provisions or be endorsed. If SUBROGATION IS WAIVED, subject to the terms and conditions of the policy, certain policies may require an endorsement. A statement on this certificate does not confer rights to the certificate holder in lieu of such endorsement(s).

<b>PRODUCER</b> Vizance, Inc. 1320 Walnut Ridge Dr Ste 200 Hartland WI 53029	<b>CONTACT NAME:</b> Jennifer DeGeorge, CIC <b>PHONE (A/C, No, Ext):</b> 262-367-8611 <b>E-MAIL ADDRESS:</b> certificates@vizance.com		<b>FAX (A/C, No):</b> 262-367-8529													
	<table border="1"> <thead> <tr> <th>INSURER(S) AFFORDING COVERAGE</th> <th>NAIC #</th> </tr> </thead> <tbody> <tr> <td>INSURER A : Travelers Casualty and Surety Company</td> <td>19038</td> </tr> <tr> <td>INSURER B : Continental Casualty Company</td> <td>20443</td> </tr> <tr> <td>INSURER C : Ascot Insurance Company</td> <td>23752</td> </tr> <tr> <td>INSURER D :</td> <td></td> </tr> <tr> <td>INSURER E :</td> <td></td> </tr> <tr> <td>INSURER F :</td> <td></td> </tr> </tbody> </table>			INSURER(S) AFFORDING COVERAGE	NAIC #	INSURER A : Travelers Casualty and Surety Company	19038	INSURER B : Continental Casualty Company	20443	INSURER C : Ascot Insurance Company	23752	INSURER D :		INSURER E :		INSURER F :
INSURER(S) AFFORDING COVERAGE	NAIC #															
INSURER A : Travelers Casualty and Surety Company	19038															
INSURER B : Continental Casualty Company	20443															
INSURER C : Ascot Insurance Company	23752															
INSURER D :																
INSURER E :																
INSURER F :																
<b>INSURED</b> INTEVID-01 Intelligent Video Solutions, LLC N53 W24747 S. Corporate Cir. Sussex WI 53089																

**COVERAGES**

CERTIFICATE NUMBER: 2146734123

REVISION NUMBER:

THIS IS TO CERTIFY THAT THE POLICIES OF INSURANCE LISTED BELOW HAVE BEEN ISSUED TO THE INSURED NAMED ABOVE FOR THE POLICY PERIOD INDICATED. NOTWITHSTANDING ANY REQUIREMENT, TERM OR CONDITION OF ANY CONTRACT OR OTHER DOCUMENT WITH RESPECT TO WHICH THIS CERTIFICATE MAY BE ISSUED OR MAY PERTAIN, THE INSURANCE AFFORDED BY THE POLICIES DESCRIBED HEREIN IS SUBJECT TO ALL THE TERMS, EXCLUSIONS AND CONDITIONS OF SUCH POLICIES. LIMITS SHOWN MAY HAVE BEEN REDUCED BY PAID CLAIMS.

INSR LTR	TYPE OF INSURANCE	ADDL INSD	SUBR WVD	POLICY NUMBER	POLICY EFF (MM/DD/YYYY)	POLICY EXP (MM/DD/YYYY)	LIMITS
A	<input checked="" type="checkbox"/> COMMERCIAL GENERAL LIABILITY <input type="checkbox"/> CLAIMS-MADE <input checked="" type="checkbox"/> OCCUR GEN'L AGGREGATE LIMIT APPLIES PER: <input type="checkbox"/> POLICY <input checked="" type="checkbox"/> PRO-JECT <input type="checkbox"/> LOC <input type="checkbox"/> OTHER:	Y		ZLP16P65005	9/1/2025	9/1/2026	EACH OCCURRENCE \$ 1,000,000 DAMAGE TO RENTED PREMISES (Ea occurrence) \$ 1,000,000 MED EXP (Any one person) \$ 10,000 PERSONAL & ADV INJURY \$ 1,000,000 GENERAL AGGREGATE \$ 2,000,000 PRODUCTS - COMP/OP AGG \$ 2,000,000 \$
A	<input checked="" type="checkbox"/> AUTOMOBILE LIABILITY <input type="checkbox"/> ANY AUTO <input type="checkbox"/> OWNED AUTOS ONLY <input type="checkbox"/> SCHEDULED AUTOS <input type="checkbox"/> HIRED AUTOS ONLY <input type="checkbox"/> NON-OWNED AUTOS ONLY			BA0X820745	9/1/2025	9/1/2026	COMBINED SINGLE LIMIT (Ea accident) \$ 1,000,000 BODILY INJURY (Per person) \$ BODILY INJURY (Per accident) \$ PROPERTY DAMAGE (Per accident) \$ \$
A	<input type="checkbox"/> UMBRELLA LIAB <input checked="" type="checkbox"/> OCCUR <input checked="" type="checkbox"/> EXCESS LIAB <input type="checkbox"/> CLAIMS-MADE <input type="checkbox"/> DED <input checked="" type="checkbox"/> RETENTION \$ 0			CUP0X825636	9/1/2025	9/1/2026	EACH OCCURRENCE \$ 5,000,000 AGGREGATE \$ 5,000,000 \$
A	<b>WORKERS COMPENSATION AND EMPLOYERS' LIABILITY</b> ANY PROPRIETOR/PARTNER/EXECUTIVE OFFICER/MEMBER EXCLUDED? <input type="checkbox"/> Y <input checked="" type="checkbox"/> N (Mandatory in NH) If yes, describe under DESCRIPTION OF OPERATIONS below		N/A	UB0X782552	9/1/2025	9/1/2026	<input checked="" type="checkbox"/> PER STATUTE <input type="checkbox"/> OTHER E.L. EACH ACCIDENT \$ 1,000,000 E.L. DISEASE - EA EMPLOYEE \$ 1,000,000 E.L. DISEASE - POLICY LIMIT \$ 1,000,000
B C	Professional Liability Cyber Liability Stop Gap Employers Liability - ND			6021628080 C-4LRV-100926-CYBER-2024	9/1/2025 9/1/2025	9/1/2026 9/1/2026	Limit 5,000,000 Limit 2,000,000 Limit 1,000,000

**DESCRIPTION OF OPERATIONS / LOCATIONS / VEHICLES (ACORD 101, Additional Remarks Schedule, may be attached if more space is required)**

Maine Township is named as additional insured under the General Liability policy when required by written contract and signed by all applicable parties prior to loss, subject to actual policy forms, terms, and conditions.

**CERTIFICATE HOLDER****CANCELLATION**

Maine Township  
 1700 Ballard Road  
 Park Ridge IL 60068

SHOULD ANY OF THE ABOVE DESCRIBED POLICIES BE CANCELLED BEFORE THE EXPIRATION DATE THEREOF, NOTICE WILL BE DELIVERED IN ACCORDANCE WITH THE POLICY PROVISIONS.

AUTHORIZED REPRESENTATIVE

© 1988-2015 ACORD CORPORATION. All rights reserved.

- iii. Vendor must provide subcontractor information and proof that work performed by the subcontractor is covered by vendor insurance**

Not applicable. IVS will not make use of subcontractors for this project.

- iv. If awarded the work by the Township Board, the Vendor must execute a contract with the Township for the work. The Contract will be on a form acceptable to the Township.**

Please see our **End User License Agreement** on the next page.

*Remainder of page intentionally left blank*

## End User License Agreement

Intelligent Video Solutions, LLC  
END USER LICENSE AGREEMENT  
for IVS VALT SOFTWARE and Related Software Products and Services

Thank you for choosing software (“Software”) from Intelligent Video Solutions (IVS). This End User License Agreement (this EULA) is a legally binding license agreement between you and IVS that describes your rights to use this software and services provided by IVS. IF YOU DO NOT AGREE TO EACH AND EVERY TERM AND CONDITION OF THIS EULA, YOU MAY NOT USE ANY SOFTWARE PROVIDED BY IVS. THIS EULA IS AN AGREEMENT TO LICENSE SOFTWARE, NOT AN AGREEMENT FOR THE SALE OF SOFTWARE.

For adequate consideration, IVS and End User (“You”) agree as follows:

- 1. Software Licensed, Not Sold.** The Software is licensed, not sold. This EULA does not transfer or modify any ownership rights related to the Software, which are exclusively held by IVS.
- 2. License Grant to the Software.** Subject to the terms of this EULA and of applicable fees, IVS hereby grants you a limited, worldwide, nonexclusive, nontransferable, revocable license, without rights to sublicense, to download and install the Software on one (1) server, and to use the Software for the purposes set forth in the applicable Software documentation, to the extent permitted by your payment of applicable fees and any specifications of your specific license grant and license type.
- 3. Title.** IVS retains all right, title and interest in and to the Software.
- 4. Intellectual Property Rights Confidential.** The IVS VALT Software is valuable trade secret(s) and the confidential and proprietary information of IVS. The Software and any copies thereof are the exclusive intellectual property of IVS and protected by copyright laws and international treaties and as well as other intellectual property laws and treaties. The structure and organization of the Software, along with its source code and object code, are confidential information and valuable trade secrets of IVS. You agree that any disclosure by you of this confidential information will cause immediate, irreparable harm to IVS for which a court of competent jurisdiction may award equitable remedies, as well as any other available legal remedies. IVS does not grant you any intellectual property rights in or to the Software. You agree to maintain the confidentiality of the Software, License Keys, and other intellectual property of IVS using your best efforts, and in no case less than reasonably prudent care for extremely sensitive and proprietary confidential information. You agree to reasonably communicate the terms and conditions of this EULA to those persons employed or engaged by you, or who otherwise come into contact with the Software, and other

intellectual property of IVS, and to use best efforts to ensure their compliance with the terms and conditions of this Section 4.

5. **Termination.** IVS may terminate this EULA immediately and without notice if you fail to comply with any term of this EULA or fail to timely pay any amounts due IVS.
6. **Effect of Termination.** In the event of termination, you must immediately and completely cease using the Software in any way, and destroy all copies of the Software.
7. **Limited Warranty.** IVS warrants that the Software will substantially conform to the description contained in the applicable end user documentation for a period of 90 days after the earlier of the date IVS provides the Software or the date you downloaded the Software. EXCEPT FOR THE PRECEDING EXPRESS LIMITED WARRANTY, TO THE MAXIMUM EXTENT PERMITTED BY APPLICABLE LAW, IVS PROVIDES THE SOFTWARE AND SERVICES WITHOUT ANY WARRANTIES OF ANY KIND, EXPRESS, IMPLIED, STATUTORY, OR IN ANY OTHER PROVISION OF THIS EULA OR COMMUNICATION WITH YOU, AND IVS SPECIFICALLY DISCLAIMS ANY IMPLIED WARRANTIES OF MERCHANTABILITY, FITNESS FOR A PARTICULAR PURPOSE, AND NON-INFRINGEMENT. IVS DOES NOT WARRANT THAT THE SOFTWARE OR SERVICES WILL MEET YOUR NEEDS OR THAT THE SOFTWARE OR SERVICES WILL BE OR PROVIDE FOR ERROR FREE OPERATION OR OPERATION WITHOUT INTERRUPTION. IN THE EVENT YOU OBTAINED THIS LICENSE FROM A RESELLER, DISTRIBUTOR, OR OTHER THIRD PARTY, IVS SHALL HAVE NO OBLIGATION TO YOU UNDER ANY WARRANTY GIVE BY SUCH RESELLER, DISTRIBUTOR, OR THIRD PARTY, OR THEIR RESPECTIVE AGENTS OR EMPLOYEES.
8. **Limitation of Liability.** TO THE MAXIMUM EXTENT PERMITTED BY APPLICABLE LAW, IN NO EVENT WILL IVS BE LIABLE FOR ANY LOST PROFITS OR BUSINESS OPPORTUNITIES, LOSS OF USE, BUSINESS INTERRUPTION, LOSS OF DATA, OR ANY OTHER INDIRECT, SPECIAL, INCIDENTAL, OR CONSEQUENTIAL DAMAGES UNDER ANY THEORY OF LIABILITY, WHETHER BASED IN CONTRACT, TORT, NEGLIGENCE, PRODUCT LIABILITY, OR OTHERWISE RELATED TO THE SOFTWARE, SERVICES, OR OTHER SUBJECT MATTER HEREOF. BECAUSE SOME JURISDICTIONS DO NOT ALLOW THE EXCLUSION OR LIMITATION OF LIABILITY FOR CONSEQUENTIAL OR INDIDENTAL DAMAGES, THE PRECEDING LIMITATION MAY NOT APPLY TO YOU.  
IVS'S LIABILITY UNDER THIS EULA WILL NOT, IN ANY EVENT, EXCEED THE FEES, IF ANY, PAID BY YOU FOR THE SOFTWARE AND SERVICES LICENSED TO YOU UNDER THIS EULA. THE FOREGOING LIMITATIONS SHALL APPLY TO THE MAXIMUM EXTENT PERMITTED BY APPLICABLE LAW, REGARDLESS OF WHETHER IVS HAS BEEN ADVISED OF THE POSSIBILITY OF SUCH DAMAGES AND REGARDLESS OF WHETHER ANY REMEDY FAILS OF ITS ESSENTIAL PURPOSE. YOU AND IVS AGREE THAT, GIVEN THE PRICE OF THE SOFTWARE



AND THE NATURE OF THE CIRCUMSTANCES, THE PRECEDING LIMITATIONS ARE FAIR AND REASONABLE.

- 9. Taxes.** You shall be solely responsible for, and shall pay directly, all taxes, duties, and charges incurred related to this EULA or the Software or Services.
- 10. Entire Agreement.** This EULA sets forth IVS's entire liability and your exclusive remedy with respect to the Software, Services, and other subject matter hereof, and supersedes the terms of any purchase orders and any other communications or advertising with respect to the Software. ANY PURCHASE ORDER OR OTHER DOCUMENT PROVIDED BY OR RECEIVED FROM YOU SHALL BE FOR YOUR INTERNAL USE ONLY AND SHALL NOT BE APPLICABLE TO IVS NOR SHALL IT MODIFY THE TERMS OF THIS EULA OR GOVERN YOUR USE OF THE SOFTWARE. IVS REJECTS ANY TERMS CONTAINED IN YOUR PURCHASE ORDERS OR SIMILAR DOCUMENTS.
- 11. Notices.** Notices required by or related to this EULA from you must be sent via U.S. Mail or reputable overnight carrier, return receipt requested, to IVS's then current mailing address, which is presently N53W24747 S Corporate Cir, Sussex, WI 53089.
- 12. Severability.** If a provision of this EULA is found illegal or unenforceable, it will be enforced to the maximum extent permissible, and the legality and enforceability of the other provisions of this EULA will not be affected.
- 13. Relationship of You and IVS.** This EULA shall not be construed to create any employment, partnership, joint venture, franchise, or agency relationship between you and IVS, or to authorize either party to enter into any commitment or agreement binding on the other party.
- 14. Governing Law.** This EULA will be governed by the laws of the State of Wisconsin without regard to its choice of law principles. Any dispute under this EULA will be venued in Waukesha County, Wisconsin.
- 15. Contact Information.** If you have any questions about this EULA, please contact IVS at [ipivs.com](http://ipivs.com).
- 16. Survival of Terms.** These terms shall survive termination of this EULA.



## 2. Company Description

- i. Please include a brief history of your company, including how long you have been in business, financial standing, insurance coverage, how many clients you serve, what types of clients you serve, and the scope of services you provide**

Intelligent Video Solutions (IVS) is an LLC taxed as an S Corporation and is member managed.

IVS is headquartered in the United States in Sussex, Wisconsin and was incorporated in the state of Wisconsin in 2009.

IVS has 60 full-time employees, and our teams are in-house, from design to installation and support, so we offer our customers long-term partnership and expertise in both software, hardware, and services for audio/video capture.

The IVS founding partners have been and continue to be the IVS core leadership team including:

- Kevin Marti, CEO - 25+ years of entrepreneurship in audio/video solutions.
- Dustin Stern, CTO - 20+ years of product development and software support.
- Steve Jacobson, CRO, 25+ years of executive sales experience.
- Justin Sherman, CMO, 20+ of video-technology sales and marketing experience.

IVS wholly owns the VALT solution. VALT is designed as a true enterprise-level solution that offers reliability, proven performance, and a robust and secure platform that safeguards your valuable data. We have implemented VALT successfully across a wide range of institutions, including higher education, healthcare, community clinics, Child Advocacy Centers, and several large multidisciplinary simulations and clinic-based facilities.

IVS can provide a turnkey video system that includes the installation of cameras and audio equipment, audio wiring, configuration of the system, training, and support. All work is performed on dates agreed upon by both parties. Installation, onsite configuration, and end user training are performed by IVS onsite. The installation takes at most five business days when the customer has met all pre-installation requirements.

Please see **25-26 Cert - Maine Township** on page 7 regarding insurance coverage.

We currently serve 909 customer partners. Our commitment to excellent customer service sets us apart as a reliable partner. We believe in building long-lasting relationships with our clients and providing ongoing support and assistance. Our dedicated customer service and technical support teams are readily available to address any queries, provide guidance, and ensure that your experience with VALT is smooth and hassle-free.

### 3. References

- i. References should include name of the company, contact info and brief description of services rendered**

**Cincinnati Children’s Hospital Medical Center – Cincinnati, OH**

Debbie Sharp - Analyst II – Application Mayerson Center for Safe & Healthy Children

- Email: Debbie.Sharp@cchmc.org
- Phone: 513-636-7001

**Family Service Agency of DeKalb – CAC – Dekalb, IL**

Holly Peifer – Director Children’s Advocacy Center

- Email: hpeifer@fsadekalbcounty.org
- Phone: 815-758-8616

**Maine Township of Georgia – Athens, GA**

Amy Kay Powell - Director – College of Family & Consumer Sciences

- Email: akay@uga.edu
- Phone: 706-543-4929

### 4. Subcontractors

- i. Vendor should list any subcontractor’s name, address and state of incorporation that are proposed to be used on the project**

IVS will not make use of subcontractors for this project.

- ii. Indicate the subcontractor’s role and responsibilities in the project**

Not applicable.

- iii. Provide proof of insurance naming Maine Township as the insured at the award of the contract**

Please see attached proof of insurance on page 7.

## 5. Scope of Services

### i. Executive Summary

Intelligent Video Solutions (IVS) supports the turnkey design, procurement, installation and support of VALT, an audio/video capture system for the Township's audiovisual recording and observation system across two counseling rooms. VALT will facilitate supervision and post-session review for student intern therapists and employee therapists who require session recordings for credentialing purposes.

IVS will provide design, project management, shipping and logistics, installation, onsite training, warranty and support. No third party or sub-contractor is required for IVS to accomplish the scope of services for this project. IVS teams are in-house, from design to installation and support, so we offer a seamless purchasing, implementation and support experience, which leads to long-lasting partnerships.

### ii. Project and Installation Plan

One of the benefits of IVS's in-house project management and installation teams is that we are agile and coordinate mutually agreeable installation dates and times with customers. An installation date is agreed upon and scheduled when a Purchase Order is received by IVS.

IVS can provide a turnkey video system that includes the installation of cameras and audio equipment, audio wiring, configuration of the system, training, and support. All work is performed on dates agreed upon by both parties. IVS preconfigures all equipment and ships it to the address specified by the Township. Installation, onsite configuration, and end user training is performed by IVS onsite at the Township. The installation takes at most five business days when the customer has met all pre-installation requirements.

Typical project milestones include:

- Maine Township accepts Statement of Work and issues Purchase Order
- Maine Township and IVS pre-installation conference call, aka, "project kickoff call"
- IVS ships equipment to the agreed upon Township shipping address
- IVS installs equipment at the agreed upon installation locations
- IVS trains Maine Township admin and end users

When a PO is received, the Township will receive an email from their dedicated IVS project coordinator inviting the Township to schedule a project kickoff call. During the kickoff call an installation week date is agreed upon by IVS and the Township, and then prerequisites leading up to the installation week are reviewed and coordinated. To ensure a productive kickoff call and keep the project on target to meet the Township's desired timeline, the Township must include Maine Township network team and IT

representatives, as well as any users involved in the administration of the system on the project kickoff call.

Based on our experience, the following work requirements for us and our university partners contribute to a successful implementation.

Intelligent Video Solutions (IVS) will coordinate the installation and configuration of all equipment with your team. All work will be performed on the dates agreed upon by both parties. Installation date will be agreed upon and scheduled during your IVS project kickoff call.

Below is a sample statement of work:

*IVS Responsibilities*

Check applicable	Service	Description
<input checked="" type="checkbox"/>	Project Management	<ul style="list-style-type: none"> <li>• Coordinate customer and IVS parties to obtain and document the required information relevant to the scope of this project.</li> <li>• Coordinate IVS technical services and IVS logistics teams to ensure delivery of all products and execution of all professional services as detailed in the IVS quotation for this project.</li> </ul>
<input checked="" type="checkbox"/>	Pre-Configuration Services	<p>Pre-configure video appliances, cameras, and encoders (if applicable) with the customer-supplied IP information to minimize work on-site.*</p> <p><i>*Requires customer-supplied IP information to be received prior to shipping</i></p>
<input checked="" type="checkbox"/>	Network Integration Services	<p>Provide a support engineer to remotely coordinate the integration and configuration of network related services (Active Directory, ACLs, SSL, etc.) with the customer’s IT department contact(s).</p>
<input checked="" type="checkbox"/>	Field Installation Services	<p>Provide IVS technicians to install the necessary hardware to complete the project as outlined in the quotation including:</p> <ul style="list-style-type: none"> <li>• Run cable for microphones and terminate microphones to audio interface device.</li> <li>• Connect and configure audio interface device and set up audio levels (if applicable).</li> <li>• Install cameras and connect cameras to network. Focus cameras if required.</li> <li>• Connect and terminate audio from audio interface to camera.</li> <li>• Run cable for VALT control devices and accessories.</li> </ul>

		<ul style="list-style-type: none"> <li>• Install VALT control devices &amp; accessories and verify normal operation (if applicable)</li> </ul>
☒	Camera Placement	<p>If not already specified, IVS can provide a recommendation based on industry best practices for the placement of cameras within all rooms at the time of installation.</p> <p>IVS will conduct an initial walk through of all rooms with a designated representative of the customer. During this walk-through placement of the cameras in each room will be agreed upon with the designee.</p>
☒	Configuration Services	<p>IVS will provide an engineer to custom configure the VALT software to meet the specific needs of the customer.</p> <p>Included in the set up and configuration of the head end is the following:</p> <ul style="list-style-type: none"> <li>• Enter IP camera information into the software and name cameras according to customer desired room names or camera ID's.</li> <li>• Work with the customer to develop custom fields associated with each camera and configure user templates for those fields.</li> <li>• Work with the customer to define user groups and define appropriate rights and access requirements for each group.</li> <li>• Set up applicable user accounts.</li> <li>• Test configuration and ensure software and all hardware is configured and works as specified.</li> </ul>
☒	Training Services	<p>VALT is easy to use, and users are trained in their actual VALT system, so training typically takes no more than 60 minutes for trainees (technical, admin, first-time adopters, etc.) to become proficient and operate independently in the system.</p> <p>Training is led by an IVS technician onsite at the conclusion of the scheduled installation week. The Township may determine the number of participants who attend onsite training. IVS customers typically choose one of the following training options:</p> <ul style="list-style-type: none"> <li>• Option A: Hold one training session for one designee that will then train their organization (we call it "Train the Trainer")</li> <li>• Option B: Hold two training sessions for users and administrators: End user training will entail operational usage and take about 60 minutes. Administrator training will cover configuration of management and software functionality and take about 60 minutes.</li> </ul> <p>If remote training is needed after onsite training, such as for a new employee or scheduled refresher training, remote training can be provided when requested by the Township with IVS technical support</p>

		<p>or the Township’s assigned IVS Regional Representative remotely via web-meeting. Remote training is covered by an active Software Support Agreement.</p> <p>In addition to remote training, the Township has access to an online library of training videos and documentation resources that are kept up to date in the IVS wiki, including a User and Admin Manual at <a href="https://ipivs.info/wiki/index.php/VALT_Manual">https://ipivs.info/wiki/index.php/VALT_Manual</a>. The IVS wiki is easily accessible from the Help section of VALT user interface. The user manual may also be easily printed from the IVS Wiki link if a physical copy is needed.</p>
--	--	--

### Maine Township Responsibilities

Check applicable	Service	Description
☒	Pre-Installation	<ul style="list-style-type: none"> <li>Complete the VALT Project Outline &amp; Permissions Spreadsheet no later than 10 business days prior to on-site or configuration date.</li> <li>Provide individual contact information for all stakeholders.</li> <li>Commit to a mutually agreed upon date of service.</li> <li>Provide site diagram and pertinent pictures to IVS.</li> <li>Provide IP/network configuration for all network devices.</li> <li>Provide a network drop with a 15’ service loop near the desired location of each camera, encoder, or other network attached device to be installed by IVS.</li> <li>Provide a POE switch with enough available power budget to power all POE devices included in the project.</li> <li>Provide power outlets to power all equipment that requires DC power. Power supplies will be provided by IVS for all gear that require DC power.</li> <li>Configure network / VLANS for server and cameras.</li> <li>Configure any internal firewalls to allow communication between the servers, cameras, and clients.</li> <li>Identify location / space for server appliances.</li> <li>Complete and return the User Permissions Spreadsheet.</li> <li>Provide IVS with user data templates (this can be done on site if required)</li> </ul>

		<ul style="list-style-type: none"> <li>• Ensure users workstations have network access to server via web browser.</li> <li>• Provide network information for IVS technician to connect to server and camera networks for configuration.</li> <li>• For Single Sign On (SSO): Schedule a remote session with an IVS technician to verify programming and functionality of the customer programmed areas.</li> <li>• Determine the FQDN (URL for accessing VALT)</li> <li>• Have furniture in place so that the IVS team can aim and install cameras based on where furniture is in each room.</li> </ul>
☒	Installation/ Configuration	<ul style="list-style-type: none"> <li>• Provide parking pass and access to site along with any keys / access information.</li> <li>• Complete initial walkthrough to specify hardware locations.</li> <li>• Provide building and room access during standard working hours, or during previously agreed upon times.</li> <li>• Provide Wireless &amp; Wired access to the camera and server IP.</li> <li>• Provide date, time, and location for training sessions for staff and ensure it has access to VALT.</li> <li>• Complete final walkthrough with IVS technician.</li> </ul>
☒	Service Postponement or Cancellation Notice	<ul style="list-style-type: none"> <li>• The customer is responsible to provide written notice of cancellation or postponement for all on-site services.</li> <li>• Any cancelation or postponement greater than 45 days will have no penalty assessed.</li> <li>• Any postponement or cancellation of less than 45 days, a 20% charge will be added to the existing cost of installation and must be paid in full prior to re-scheduling. If all plans are canceled, 20% of all installation costs will be non-refundable.</li> <li>• Any postponement or cancellation of less than 14 days, a 40% charge will be added to the existing cost of installation and must be paid in full prior to re-scheduling. If all plans are canceled, 40% of all installation costs will be non-refundable.</li> </ul>

### iii. Project Team

IVS will provide a single project manager to coordinate with the Township.

Our installation technicians and support engineers are Axis Communications Certified technicians. They are also Biamp certified and have been programming and commissioning Digital Signal Processing audio systems for more than 6 years. We actively certify new staff as part of our training processes and provide continuing certification as new technologies become available to our existing staff.

With an active Software Support Agreement, the IVS support team may be contacted Monday – Friday, 7 a.m. to 7 p.m. CST using any one of the following methods:

- Phone: 262-746-9290 (monitored 8-5 M-F CST)
- Email: [support@ipivs.com](mailto:support@ipivs.com) (monitored 8-5 M-F CST)
- Booking: <https://ipivs.com/book>

The above contact information is readily accessible in the VALT user interface Help tool to make it easily accessible to end users.

Our support model is what we call a “swarm” model. If you call IVS for support, our goal is for the IVS technician who answers your call to stay on the line with you through the entire call until resolution. Instead of transferring you through an escalation tree, which is a frustrating experience, the IVS technician finds their colleagues and works with them to resolve your issue. The experience is transparent and easy for you. You never have to re-explain your problem because the support technician is the one collaborating with their colleagues to help you, right now. To back this up, we have a first call resolution rate of 96 percent. That means that 96 percent of the time someone calls support, their problem is solved by the end of that call. Comparative metrics in lots of organizations would be closer to 65 or 70 percent.

In addition to our in-house support team, the Township’s dedicated account management team includes Josh Riebe, Mideast Regional Director, and Nathaniel Brost, Mideast Regional Representative. Josh and Nathaniel support our partners in Illinois, Indiana, Michigan, Kentucky, Ohio and Wisconsin. They work together to help prospects evaluate and implement VALT and then support long-term partnerships with our customers. Nathaniel conducts routine VALT reviews with current customers to review how the system works for the customer, provide additional or refresher training as needed at no cost, and share new VALT features and available updates that support each customer’s use case.

#### iv. Product Information

##### 53011 VALT1E

IVS uses a perpetual license model to help our customer partners maintain low operational costs. The VALT license (**53011 VALT1E**) is a one-time, up-front cost, not a software subscription. VALT is licensed per camera and encoder. For example, when you buy a VALT license for a camera, you do not need to repurchase that license, so when you replace the camera, you originally bought in five to seven years, the VALT license simply transfers to the new camera model.

With a VALT license, there is no limit to the number of users or user groups that may be configured in the VALT software as needed, which contributes to budgetary stability.

A single VALT license provides the entire VALT software functionality with initial investment. There is no pay per module or tier license structure that would require sacrificing features or functionality to save cost.

VALT is a web-based application and there is no client installation on customer-provided hardware or customer-owned computers. No third-party applications or add-ons are required to stream, record, or playback audio and video. This makes VALT exceptionally easy for the Township to deploy and maintain as the audio/video solution for simulation.

VALT is easily accessible to users with proper credentials from any networked device. Users simply access VALT to observe live or playback recorded videos from any networked device, such as a PC, laptop or tablet. For example, to observe a session via VALT a user may select a room name, which automatically opens the camera streams associated with the room in VALT for observation. User rights prevent users without proper permissions from logging into the system and viewing a session which they have not initiated or have rights to view. And to playback recorded video, users open VALT in the web-browser of a networked device and select the video they want to play. They can also mirror or cast their device display or physically connect their device to a larger monitor display when needed. There is no need for, or restriction to, vendor-provided computers or tablets for video management, which reduces up front and maintenance costs, and frees up where and when review of video may take place.

VALT has multiple workflow options to start, stop, and pause recording. VALT has the capability to both schedule recordings and initiate ad hoc recording in the user interface or with a start/stop button. The start/stop button is paired with a privacy button in a single gang wall plate to invoke privacy in a room, which turns off the video at the camera level and allows audio-only to be streamed and recorded, as requested by the Township for this project.

Users with proper permissions use VALT's comments tool to add written and/or audio tags to video when observing live recorded simulations and when reviewing recordings in playback. Comments are automatically time stamped, authored, and indexed with color-coded markers in the video timeline to support intern and employee review.

When a recording ends, users access video for playback they have permission to view in the Review section of VALT. Videos are immediately available for playback. VALT video uses non-proprietary MP4 file formatting and h.264 video compression, which minimizes network demands and permits video to be

readily available on the server, with no lag-time associated with video rendering or exporting, so instructors and learners may have timely review following a recording session.

Videos in Review appear in a list format, or a thumbnail format based on user preference. By default, videos are organized by the most recent video file first, however a user may sort video files by available column headings such as room, author, markers, and recording name.

VALT's search engine also allows users to use a keyword search box to retrieve recordings based on metadata associated with the video file, such as date, author, room, or keywords entered in the video indexing template, tags, or assessments.

After retrieving a video in VALT, a user can navigate the recorded video by clicking on previously added comments or annotations in the timeline or comments pane to the left of the video window. VALT includes standard video player controls such as play, pause, step back (goes back 10 seconds), step forward (goes forward ten seconds), audio level, playback speed (adjust playback speed from 1/8x to 8x).

When a user selects a tag that was added to the recording, the video jumps all camera views recorded together to that moment in the video to start playback. The comments feature in video playback also includes a 'pause' function that automatically pauses the recording while the user adds their comment and then automatically resumes video playback when the user enters their comment. The video can also automatically pause to playback audio comments then automatically resume playback when the comment ends. Comments and markers may be added in playback. Existing comments may also be revised, and revised comments display who made the edit and when.

Recording data (information, comments, and evaluation template information) may be edited, with proper permission, during playback. VALT also includes a clip and redact tool to excerpt or clean up video files. Clip and redact tools do not impact the initial recording, they simply create an edited copy.

Video retention settings may be defined per user group. The retention feature allows content to be automatically deleted from VALT according to the preset retention duration (hours, days, weeks, months, years, or keep forever). Users with proper permission may revise the retention date of individual video files to override the auto-delete function and save the file for long term storage.

Simple configuration of VALT provides each group with their preferred workflows and video management to support their objectives. User permissions are granular and specific and may be defined at the "user group" and "user" level to ensure appropriate access control. More than 75 features of the VALT software may be turned on or off by user group, which shortens the learning curve and secures video and data. VALT does not restrict customers to vendor-defined roles and permission settings. VALT permissions are tailored to each organization's programs and user groups to meet their specific security compliance requirements.

In addition to user permissions the following technical safeguards are supported:

- VALT's robust audit log feature creates an audit trail of who logged in and from what device, date/time (00:00:00), IP address, cameras viewed by user, recordings initiated by user, video content accessed by user, administration changes by user, and system alerts by device. This information is searchable, sortable, and exportable into .pdf and .csv reports. Audit logs may not be modified and are stored for the duration specified by the University.

- Also supported is full SSL and video encryption via RTMPS (Wowza StreamLock™).
- Each user group may be allocated its own set of cameras. This allows the customer to easily segment and departmentalize groups and isolate them from each other even though they share the same infrastructure.
- “Containers” allow multiple disciplines to share the same infrastructure yet maintain complete privacy amongst each other.

### 90010 SSA

The only annual reoccurring cost is 90010 SSA, which is our Software Support Agreement. The Software Support Agreement includes unlimited software updates, support calls during Monday – Friday 7 a.m. to 7 p.m. CST, and a 5-year hardware warranty. The Software Support Agreement and Service Level Agreement statement follow. The Hardware Warranty statement is included on page 44.

*Remainder of page is intentionally left blank.*

## Software Support Agreement

### Overview

The Software Support Agreement (SSA) is an annual subscription that includes:

- Technical Support
- Maintenance
- Software Upgrades

### Term

The term is 12 months starting after the invoice date.

### Vendor Responsibilities (IVS)

IVS will notify Customer of enhancements, updates and bugfixes these will be published in one of the following methods: IVS's website or wiki, email, telephone or written letter. IVS will, from time to time, notify Customer with relevant documentation revised to reflect significant updates and enhancements to the Software made by IVS, if any, while the customer is under SSA using one or more of the following methods: IVS's website or wiki, email, telephone or written letter. IVS will supply Customer with reasonable means of accessing and applying modifications and enhancements to the Software, through the use of a network download or remote session. IVS is not obligated under this Agreement to perform on-site installation of modifications and enhancements to the Software.

### Customer Responsibilities

Customer agrees to follow the IVS's minimum hardware and software requirements in order for the Software to function properly in a production environment. Customer agrees that IVS is not responsible, nor obligated to change the Software due to Customer's change in business practices, policies or procedures. However, Customer may request new features or upgrades to accommodate all or part of said practices, policies or procedures. Customer acknowledges that it is the sole responsibility of the Customer, at all times, including specifically during all service functions performed by IVS pursuant to this Agreement and undertaken on the Customer's local installation of the supported Software, to protect and maintain an up-to-date and restorable backup of any and all related databases and files. Customer also must provide and keep up to date proper contact information for notification purposes.

### Technical Support

The Customer may receive support by calling IVS's telephone support phone number, email or by booking a support appointment.

- *Phone: 262-746-9290 (monitored 7 am - 7 pm M-F CST)*
- *Email: [support@ipivs.com](mailto:support@ipivs.com) (monitored 7 am - 7 pm M-F CST)*
- *Booking: <https://ipivs.com/book>*

Support assistance may be delivered by telephone, email and/or remote assistance via a web meeting. Support will be provided to the Customer for assistance with software bugs, repair of known issues, troubleshooting of software malfunctions, installation and deployment, general questions, end user questions, software administration and best practices procedures. IVS is not responsible for software or hardware of third parties, but may, at the discretion of the support engineer, assist in troubleshooting these third-party hardware/software issues as they relate to the IVS Software. IVS will give reasonable assistance to Customer in installing and operating any new release or enhancement, provided, however, that if such assistance is to be provided onsite, such services will be charged at IVS's then current consulting rate.

### **Software Maintenance**

While the customer is under the SSA, IVS will provide the Customer with patches, bug fixes, and new releases of the Software along with other generally available technical material. All patches, bug fixes and releases shall be subject to the license agreement related to the Software.

### **Software Upgrades**

If under SSA the customer is eligible for all software upgrades. Customer agrees that the releases of software upgrades are at the sole discretion of the IVS and shall follow the IVS's internal quality standards. Further, IVS will choose software features to be depreciated or included. If a customer not engaged in a current SSA wants a software upgrade they will be required to purchase an upgrade at a rate of the IVS's current upgrade pricing.

### **Support Hours**

Monday - Friday 7:00 AM - 7:00 PM (CST)

### **Upcoming IVS Holidays**

- Memorial Day – Monday, May 25th
- Independence Day – Friday, July 3rd
- Labor Day – Monday, September 7th
- Thanksgiving – Thursday and Friday, November 26th and 27th
- Christmas Eve – Thursday, December 24th
- Christmas Day – Friday, December 25th
- New Year's Eve Day - Thursday, December 31<sup>st</sup>
- New Year's Day – Friday, January 1<sup>st</sup>.

### **Unresolved Calls**

Not all calls may be resolved while the technician is on the phone. Some calls require testing and/or assistance from our development department to resolve. IVS will keep the designated contact person updated as to the status of the open call if the problem cannot be resolved while on the phone with the technician.

**Non-Support Agreement**

If a customer not engaged in a current SSA wants a Software upgrade or technical support they will be required to purchase a SSA for a minimum of 1 year and may be subject to a re-activation fee.

## Service Level Agreement

### Overview

This Service Level Agreement “SLA” covers all support and maintenance services provided by Intelligent Video Solutions “IVS” to the customer relating to the VALT (“Video Audio Learning Tool”) and BEAM Software packages. This agreement is effective from the date of installation of the VALT Software and will continue while the customer is under an active support and maintenance agreement.

This agreement is subject to change at the discretion of Intelligent Video Solutions.

### Scope

Intelligent Video Solutions will provide technical assistance and troubleshooting for the following items:

- *Software issues related to the VALT or BEAM applications.*
- *Hardware issues related to the VALT appliance (physical appliances only), IP cameras, microphones or other related equipment purchased by the customer from IVS and installed by IVS or an IVS certified reseller.*
- *Customer provided devices utilized to access the VALT Software.*
  - *Troubleshooting and support of client-side issues will be limited to assisting the customer in identifying any issue related to access to the VALT Software. Once the issue has been identified it will be the customer’s responsibility to resolve any issues related to customer supplied devices.*

### Maintenance

At the customer’s request Intelligent Video Solutions will perform requested maintenance on customer owned VALT physical and virtual appliances. These maintenance activities may include the following:

- *Installation of OS level updates*
- *Installation or integration of third-party applications, such as a backup agent, on the VALT server.*
  - *All such third-party applications must first be reviewed by IVS. IVS reserves the right to deny the installation of any third-party application.*
- *Change in configuration to the VALT application, the underlying OS, or any support applications required to run the VALT Software. Any customer requested changes are subject to approval by IVS.*

All maintenance requests must be scheduled with IVS and must occur during the support hours stipulated in this agreement.

### Updates

Intelligent Video Solutions will perform updates to the VALT Software periodically. Notice of all major releases will be provided to the customer within 30 days of release. This notice may take the form of on IVS's website or wiki, email, telephone or written letter. All updates must be requested by customer and scheduled a minimum of 24 hours in advance with IVS. No updates will be applied to a customer owned appliance without prior approval from the customer.

### **Limitations**

Intelligent Video Solutions will not be responsible for any support for equipment provided by or installed by an authorized reseller or other third party. For the purposes of this SLA, a customer performing a self-install will be considered a third-party installer. The only exception to this policy will be the VALT Software, which IVS will provide support for. Any issues that IVS identifies as being related to hardware provided by a reseller or installation work completed by a third-party installer, will be the responsibility of the that party to resolve.

### **Severity Levels**

Intelligent Video Solutions will classify all support and maintenance requests with a severity level according to the following list. The severity level will be used to determine the required response time as stipulated in the Target Response Section below. When determining a severity level, the following conditions will be taken into consideration:

- Impact of Issue on Customer Workflow
- Time Sensitivity of Issue
- Extent of Issue
- Availability of a Work Around
- Method of Submission

#### Severity Level 1

VALT application is completely down and unusable. The customer's workflow is severely impeded by the outage of the video recording software.

#### Severity Level 2

VALT application is experiencing a critical issue resulting in reduced functionality. This issue is directly impacting the customer's workflow.

#### Severity Level 3

The issue relates to the VALT application, but does not affect all users of the system. Most users are able to utilize the VALT software without issue or the issue does not significantly impact the customer's workflow.

#### Severity Level 4

The issue is maintenance related and does not significantly impact the customer's workflow. Severity levels often cannot be properly assigned until the situation is assessed by an IVS technician.

All issues will be assigned a severity level based upon the initial reporting. That severity level may be adjusted after an IVS technician has reviewed the situation.

### Target Response Times

Any issues submitted during covered support hours will be assessed by an IVS technician and assigned a priority. IVS will make every effort to respond to all support issues in a timely manner. The chart below outlines the target response times for all issues based on severity. All times listed are based on covered support hours. Any issues submitted outside support hours will be treated as having been submitted at the beginning of the next support day.

Severity Level	Target Response Time
1	Two Hours
2	Four Hours
3	One Day
4	One Week

Intelligent Video Solutions recognizes that resolution of an issue may require multiple resources both from IVS, the customer, and third parties. As such, IVS offers no guarantees or warranties as to resolution timeframe for any reported issue. All issues will be resolved on a best effort basis.

### Optional On-Site Service Agreement

An IVS on-site warranty must be purchased in advance. An on-site service call can only be scheduled by an IVS technician after remote diagnostics are done. The target response time to get a technician onsite with the appropriate hardware to fix the issue is 10 business days (~2 weeks).

### Customer Support

All support and maintenance issues should be submitted to IVS via one of the methods listed below.

- Phone: 262-746-9290 (monitored 8-5 M-F CST)
- Phone: 262-XXX-XXXX (monitored 24x7)
- Email: [support@ipivs.com](mailto:support@ipivs.com) (monitored 8-5 M-F CST)
- Booking: <https://ipivs.com/book>

Any issues submitted via email will automatically be classified as a severity three or below. IVS should always be notified of critical issue via phone. The customer acknowledges by submitting an issue via the booking page that they are selecting a support time of their choosing and forgo any expectation of response times listed in this document. Support issues should not be reported directly to any IVS employee or contractor. IVS cannot guarantee response time or resolution of any issues not reported to IVS customer support in the appropriate manner.

### Customer Responsibilities

- *Maintain a record of the configuration of the VALT application and any related equipment for use by IVS support in troubleshooting any issues related to the VALT Software.*
  - *IVS does not maintain a record of this information for any customer.*
- *Provide remote access to IVS support to the VALT server, IP cameras, and any computers experiencing an issue to facilitate troubleshooting.*
  - *IVS does not maintain any external access to customer owned hardware.*
  - *Remote access can be provided via Splashtop, Zoom, or any other remote software available to both IVS and the customer without any additional cost to IVS.*
- *Provide the necessary passwords to IVS support personnel to access the VALT appliance and all related equipment.*
- *Provide IT support staff to assist in troubleshooting and resolving any issues related to the VALT Software. This includes making required changes to networking, firewalls, antivirus, or any other software or hardware as required to restore the VALT Software to normal operating condition.*
- *Provide staff on site to assist with minor physical troubleshooting of issues related to the VALT Software. This includes, but is not limited to:*
  - *Rebooting Cameras*
  - *Verifying Equipment Status*
  - *Checking Wiring*
- *Maintain the VALT appliance and any related equipment in a climate controlled environment and ensure the equipment is not subject to physical damage.*
- *Back up the VALT database and all video files on the VALT appliance(s).*
- *Internet access may be required on the server to apply patches, bugfixes or updates.*

### Charges

Unless stated otherwise, all services associated with the maintenance and support of the VALT application and related equipment will be covered under the VALT maintenance and support agreement.

The maintenance and support agreement covers remote support services only. Any issues that cannot be resolved remotely which require a site visit from a VALT technician or contractor, may be billable. Billing for such services may include both on site hours and travel expenses.

Product sheets are provided next to share information about the proposed hardware for the VALT system, and the BEAM mobile companion app (which simply uses a VALT license on an iOS device).

*Remainder of page intentionally left blank*



## VALT SERVER

### T1A2S SPECIFICATIONS



“ INTELLIGENT VIDEO SOLUTIONS OFFERS A DISCIPLINED, ENTERPRISE CLASS TOOL. VALT FITS, WORKS AND IS SECURE. ”

Michael Barr, CIO  
Mt. Royal University

VALT servers are Tier One platforms featuring the industry's most trusted suppliers hand selected for video optimization and maximum uptime. Prior to leaving the manufacturing environment every component is tested, validated and burned in ensuring your VALT system is ready to perform out of the box.

Each server is meticulously prepared in our configuration center with VALT licensing and software to create a custom-built appliance for any size video observation and recording project.





The T1A2S is a micro-tower chassis featuring an INTEL Core Ultra 5 235 CPU, 16GB RAM, and 2 TB of video storage. This appliance is benchmarked to manage up to five 1080p cameras and offers 1,000 hours of video archive.

### TECHNICAL SPECIFICATIONS

MODEL NAME	T1A2S
FORM FACTOR	MICRO TOWER
CAMERAS	25
OS	UBUNTU LINUX 24.04
STORAGE DRIVE	2TB SSD TLC WITH DRAM M.2 2280 PCIE GEN4 SED READY
CPU	INTEL CORE ULTRA 5 235
CACHE	24 MB
CORES	14
THREADS	14
SPEED	2.9 GHZ
MEMORY	16GB: 2 X 8 GB, DDR5, 5600 MT/S, NON-ECC
HEIGHT X WIDTH X DEPTH	8.11" X 3.12" X 7.00"
MOUNTING	FREE STANDING OR VESA WALL MOUNT
MOTHERBOARD	DELL PRO MAX MICRO MOTHERBOARD
POWER SUPPLY	280W A/C ADAPTER, EPEAT5, 7.4MM BARREL, TCO10
AVG. POWER CONSUMPTION	100W
BTU/HR	338
VIDEO STORAGE	1000 HOURS*

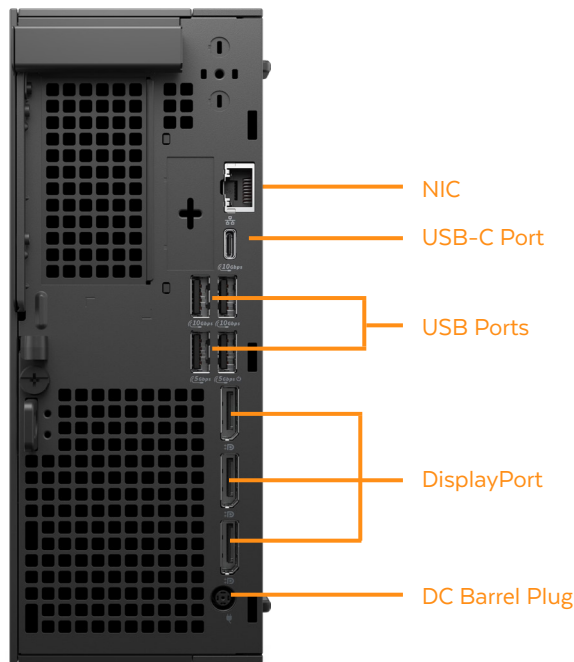

All VALT Servers are backed by a 5-year next business day on-site repair warranty.

To request warranty services please contact Intelligent Video Solutions by phone: 262-746-9290 or email: [support@ipivs.com](mailto:support@ipivs.com).

\* Estimated retention hours for use with 1080P cameras for 720P cameras multiply by 2  
Additional information available at [ipivs.com/products/#servers](http://ipivs.com/products/#servers)

## AXIS P3275-LV Dome Camera

### Indoor 2 MP AI-powered dome

This AI-powered camera delivers excellent image quality in 2 MP under any light conditions. Built on ARTPEC-9, it offers accelerated performance to run impressive analytics applications on the edge. It comes with AXIS Object Analytics to detect, classify, track, and count humans. In addition, AXIS Live Privacy Shield makes it easy to remotely monitor activities while protecting privacy. This robust, IK10- and NEMA 4X-rated camera is both vandal- and impact-resistant. Furthermore, Axis Edge Vault, a hardware-based cybersecurity platform, safeguards the device and protects sensitive information from unauthorized access.

- > [Excellent image quality in 2 MP](#)
- > [Next-generation AI-powered analytics](#)
- > [Lightfinder 2.0 and Forensic WDR](#)
- > [Audio and I/O connectivity](#)
- > [Built-in cybersecurity with Axis Edge Vault](#)



# AXIS P3275-LV Dome Camera

## Camera

### Image sensor

1/2.8" progressive scan RGB CMOS  
Pixel size 2.9 µm

### Lens

Varifocal, 3.4–9.8 mm, F1.4–2.7  
Horizontal field of view: 100°–32°  
Vertical field of view: 52°–18°  
Minimum focus distance: 1 m (3.28 ft)  
IR corrected, remote zoom and focus, P-Iris control

### Day and night

Automatic IR-cut filter

### Minimum illumination

Color: 0.08 lux at 50 IRE, F1.4  
B/W: 0.02 lux at 50 IRE, F1.4  
0 lux with IR illumination on

### Shutter speed

1/37000 s to 2 s

### Camera adjustment

Pan ±190°, tilt -45 to +80°, rotation ±95°

## System on chip (SoC)

### Model

ARTPEC-9

### Memory

2 GB RAM, 8 GB Flash

### Compute capabilities

Deep learning processing unit (DLPU)

## Video

### Video compression

H.264 (MPEG-4 Part 10/AVC) Baseline, Main and High Profiles  
H.265 (MPEG-H Part 2/HEVC) Main Profile  
AV1  
Motion JPEG

### Resolution

16:9: 1920x1080  
16:10: 1280x800  
4:3: 1440x1080

### Frame rate

Up to 50/60 fps (50/60 Hz) in all resolutions

### Video streaming

Up to 20 unique and configurable video streams<sup>1</sup>  
Axis Zipstream technology in AV1, H.264 and H.265  
Controllable frame rate and bandwidth  
VBR/ABR/MBR H.264/H.265/AV1  
Low latency mode  
Video streaming indicator

### Signal-to-noise ratio

>55 dB

### WDR

Forensic WDR: Up to 120 dB depending on scene

### Multi-view streaming

Up to 7 individually cropped out view areas

### Noise reduction

Spatial filter (2D noise reduction)  
Temporal filter (3D noise reduction)

### Image settings

Saturation, contrast, brightness, sharpness, white balance, day/night threshold, local contrast, tone mapping, exposure mode, exposure zones, defog, barrel distortion correction, compression, rotation: 0°, 90°, 180°, 270° including corridor format, mirroring, dynamic text and image overlay, overlay widget, privacy masks, target aperture

### Image processing

Axis Zipstream, Forensic WDR, Lightfinder 2.0, OptimizedIR

### Pan/Tilt/Zoom

Digital PTZ, preset positions  
Guard tour, control queue

1. We recommend a maximum of 3 unique video streams per camera or channel, for optimized user experience, network bandwidth, and storage utilization. A unique video stream can be served to many video clients in the network using multicast or unicast transport method via built-in stream reuse functionality.

**DESCRIPTION**

The Verifact® D is an electret condenser microphone with pre-amp and omni-directional pattern. It provides listening capabilities between the area of coverage and the Louroe Base Station, or other audio receiving devices. Microphone assembly is mounted to the back of a single gang stainless steel faceplate that fits into a single gang electrical box. Verifact® D Microphone is compatible with all Louroe Base Stations. The unit can be flush or surface mounted to a wall or ceiling. Electrical box not included.



**VERIFACT® D**  
**Microphone**

**APPLICATION**

As part of a Louroe Audio System, the Verifact® D Microphone can be used in situations such as:

- Convenience Stores
- Warehouses
- Interrogation Rooms
- Hospital Observation Rooms
- Or anywhere CCTV cameras are installed
- Parking Structures
- Booking Rooms
- Casino Soft Count Rooms

**WIRING REQUIREMENTS**

2 Conductor **shielded** cable, 22 gauge with a 24 gauge drain wire

**NOTE:** Unshielded cable is not satisfactory for audio systems



**FEATURES**

- High sensitivity to low sound pressure
- Microphone can pick up normal sounds 15' away
- May be located up to 1000' from base station
- Phantom powered from Louroe Base Station
- Microphone preamp contains sensitivity switch for lowering gain
- Fits into single gang electrical box (not included)
- Flush or surface mount to wall or ceiling

**SPECIFICATIONS**

■ Sensitivity	-45 dBV/Pa 1 Pa = 94 dB SPL
■ Frequency Response	50 Hz to 15 kHz
■ Output	Line Level (0 dBV, 600Ω @ 1kHz)
■ Current Drain	10mA
■ Supply Voltage	12 Vdc
■ Microphone Housing	Stainless faceplate
■ Dimensions (Faceplate)	2 3/4" W x 4 1/2" H
■ Weight	2.5 oz
■ Shipping Weight	1 lb

**IMPORTANT NOTICE**

When this equipment is used as part of an audio monitoring system, the law requires that the public be given notice of AUDIO MONITORING ON THE PREMISES. A decal notice is included with each microphone shipped.



Federal LawReferences:  
 Federal Regulations, US Code, Title 18.  
 Crime and Criminal Procedure, Sec2510.



# STICK-ON® SERIES

## Model ST-DA3

### Distribution Amplifier

## Installation/Operation



Declaration of Conformity available from [rdinet.com](http://rdinet.com).  
Sole EMC specifications provided on product package.  
Specifications are subject to change without notice.

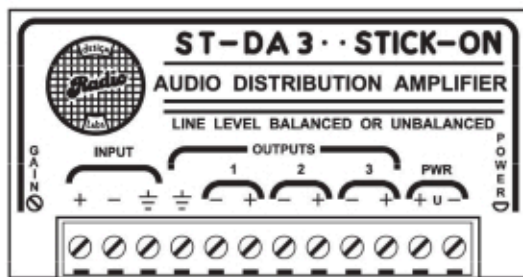

### AUDIO WIRING

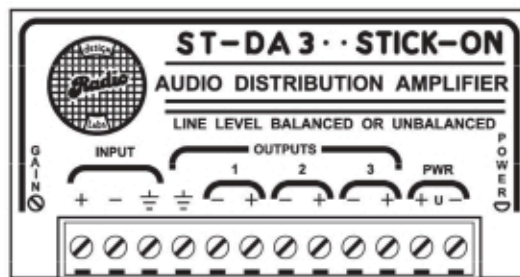

SIGNAL FROM BALANCED LINE-LEVEL SOURCE

SIGNAL FEEDING BALANCED LINE-LEVEL EQUIPMENT

OTHER BALANCED OR UNBAL OUTPUTS

25 TURN GAIN SET ADJUSTMENT

SIGNAL FROM UNBALANCED LINE-LEVEL SOURCE

SIGNAL FEEDING UNBALANCED LINE-LEVEL EQUIPMENT

OTHER BALANCED OR UNBAL OUTPUTS

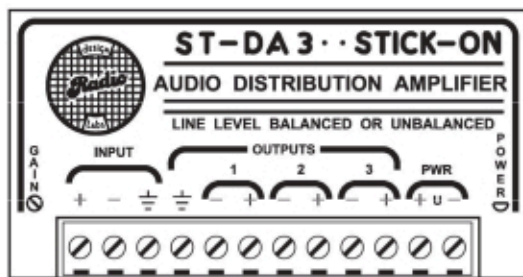

### SUPPLY WIRING

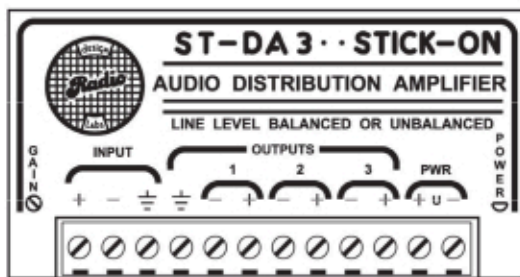

DO NOT GROUND NEGATIVE FOR FLOATING OR BIPOLAR POWER INSTALLATION

OR GROUND NEGATIVE FOR GROUND-REFERENCED POWER INSTALLATION

OPTIONAL JUMPER (WHEN USING GROUND-REFERENCED POWER SUPPLY)

RDL PS-24 TYPE SUPPLY

24 Vdc POWER SOURCE

AUXILIARY BIPOLAR SUPPLY

12 12  
G OR OR  
N 15 15  
D Vdc Vdc  
BIPOLAR SUPPLY

### TYPICAL PERFORMANCE

Input: 20 k $\Omega$  balanced or unbalanced  
 Input Signal: -15 dBV to +21 dBu (for +4 dBu output)  
 Maximum Input Level: +24 dBu  
 Outputs (3): 150  $\Omega$  balanced or 75  $\Omega$  unbalanced  
 Output Signal:  
   Balanced: +4 dBu nominal  
   Unbalanced: 6dB below balanced line-level  
 Maximum Output Level: +25 dBu  
 Frequency Response: 10 Hz to 100 kHz ( $\pm 0.05$  dB)  
 THD+N: < 0.002% (unity gain)  
 IMD: < 0.003% (unity gain)

Noise below +4 dBu: < -98 dB (unity gain)  
 Headroom: > 20 dB (above +4 dBu)  
 Gain: Unity  $\pm 17$  dB (adjustable)  
 CMRR: > 60 dB (50 Hz to 120 Hz)  
 Indicator: Red LED power indicator  
 Power Requirement: GROUND-REFERENCED or FLOATING  
   24 Vdc @ 70 mA  
 Ambient Operating Environment: 0° C to 55° C  
 Dimensions:  
   Width: 3.00 in. 7.62 cm  
   Depth: 1.55 in. 3.94 cm  
   Height: 0.65 in. 1.65 cm

# VALT Privacy & Record Buttons

Start/stop capability in or near the room and enable privacy mode to restrict access to live view or record video

- Single gang wall plate
- Push button
- LED indicator
- Light = recording in progress
- Red or Blue record button option
- Green = privacy enabled
- Dark = privacy disabled



# Observation Room Audio Solution (ORAS-K)

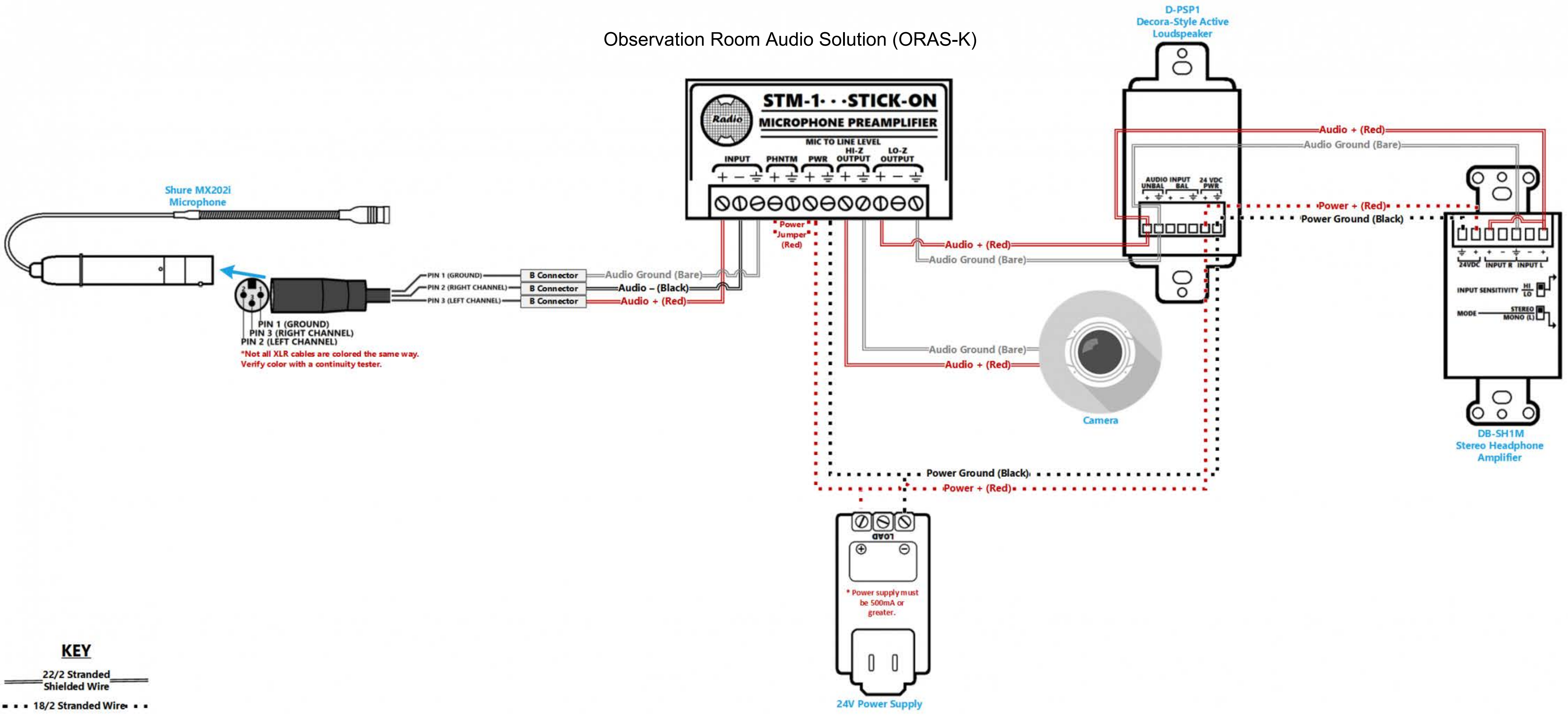



THE SECURE,  
SCALABLE AND  
SEAMLESS MOBILE  
VIDEO SOLUTION

## Secure video in the three places you need it most: Here, there and everywhere.

You already know video recording helps achieve your goals. You may even use an iOS device to capture video in the field. BEAM, our mobile application, works with the VALT server to turn your iOS device into a video capture solution that is more secure, scalable, and effective. Users capture video anywhere and video assets are Beamed directly to VALT with descriptive metadata, enabling your organization to maintain security compliance standards and build a robust, powerful video database.

### APPLICATIONS



#### CLINICAL SKILLS

Off-site treatment sessions,  
Video self modeling



#### SIMULATION

Real-world scenarios,  
Practitioner point of view

#### EDUCATION AND TRAINING

Student teaching/practice, On-site  
safety/procedures

#### INTERVIEWS

Field interviewing, HR documentation

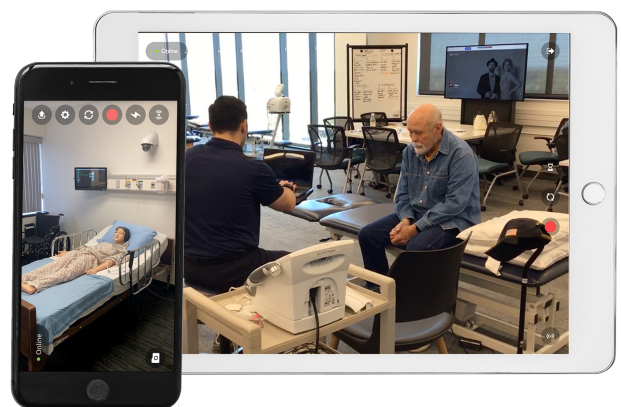

LEARN MORE



“ON THE GO. AS THINGS HAPPEN. BEAM MAKES THE SECURE RECORDING AND MANAGING OF VIDEO CONTENT EASIER THAN EVER.”

## FEATURES

- Available for iPad, iPad mini and iPhone via App Store
- Stream live video directly to VALT for on-premise wireless AV
- Record off-site/in offline mode
- Auto-upload video securely to VALT server
- HD video via front (720p) or back (1080p) camera
- Review stored videos
- Manage stored videos
- User authentication/sync via VALT server
- Custom data capture fields via VALT server
- Automate mobile video management

## WHY CHOOSE BEAM?



### SECURITY AND MANAGEMENT

Capturing video is easy. Managing all that data is complex. Beam works exclusively with authorized users from the IVS VALT server so all security, metadata and permissions follow the video asset.



### TRUE HD MOBILITY

Long battery life with front/back camera options make a Beam iOS device a truly flexible, mobile HD video recording platform.



### APPLICATION SPECIFIC ACCESSORIES

While iOS devices can effectively record video on their own, IVS creates custom 'kits' that include accessories to meet any AV recording challenge.

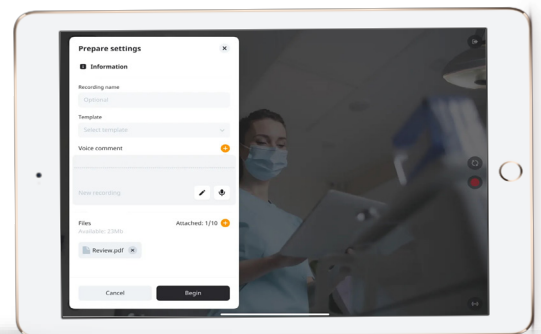
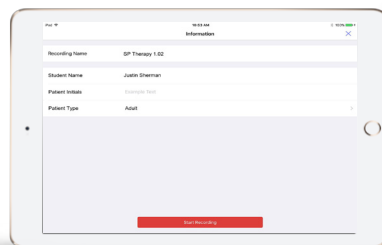

v. **Diagram of Design**

Network Architecture

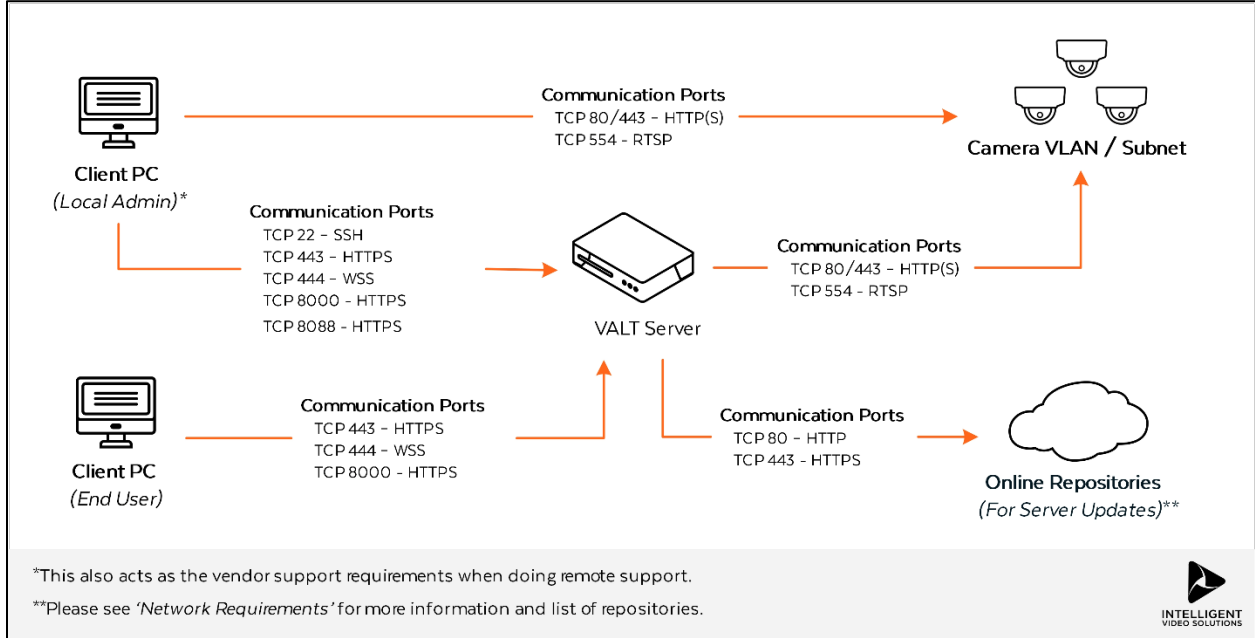

Sample Room Design

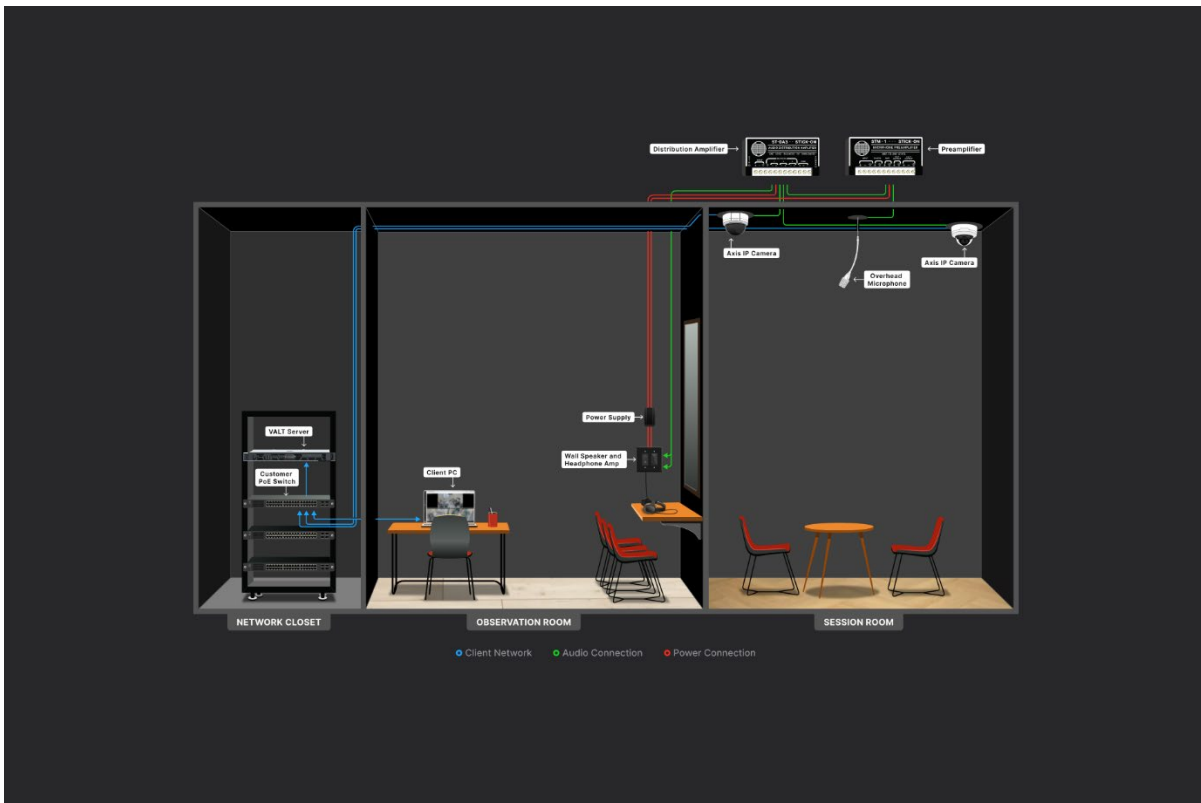

## vi. Equipment Listing

Please see quote name **2602111031JR** on page 47 for a complete equipment list.

## vii. Permits

Not applicable.

## viii. Training

VALT is easy to use, and users are trained in their actual VALT system, so training typically takes no more than 60 minutes for trainees (technical, admin, first-time adopters, etc.) to become proficient and operate independently in the system.

Training is led by an IVS technician onsite at the conclusion of the scheduled installation week. The Township may determine the number of participants who attend onsite training. IVS customers typically choose one of the following training options:

- Option A: Hold one training session for one designee that will then train their organization (we call it “Train the Trainer”)
- Option B: Hold two training sessions for users and administrators: End user training will entail operational usage and take about 60 minutes. Administrator training will cover configuration of management and software functionality and take about 60 minutes.

If remote training is needed after onsite training, such as for a new employee or scheduled refresher training, remote training can be provided when requested by the Township with IVS technical support or the Township’s assigned IVS Regional Representative remotely via web-meeting. Remote training is covered by an active Software Support Agreement.

In addition to remote training, the Township has access to an online library of training videos and documentation resources that are kept up to date in the IVS wiki, including a User and Admin Manual at [https://ipivs.info/wiki/index.php/VALT\\_Manual](https://ipivs.info/wiki/index.php/VALT_Manual). The IVS wiki is easily accessible from the Help section of VALT user interface. The user manual may also be easily printed from the IVS Wiki link if a physical copy is needed. The online training content accessible via the VALT user interface is an available “quick start” resource for the Township’s internship students.

## ix. Service Call Information

If remote diagnostics by the IVS support technicians determine a service call is required, our support team will request a quote for a service call from the regional account management team. Your account



Maine Township  
Clinical Observation and Recording System

management team will provide the Township with the quote for service to sign or provide a Purchase Order(PO). A service call may provide the following:

- Provide onsite troubleshooting for audio wiring.
- Testing, configuration, and troubleshooting of advanced audio solutions purchased from IVS.
- Replacement and configuration of equipment purchased from IVS.

**x. Warranty**

*Remainder of page intentionally left blank*

## Hardware Warranty Statement

### Overview

IVS provides a standard warranty on all hardware sold and warranty on all labor including wiring. This includes but is not limited to IVS supported products that are listed below. For any warranty replacement IVS reserves the right to replace a part or device with a comparable or refurbished model.

- *All servers carry a depot repair / component replacement warranty.*
- *All cameras carry a depot repair /replacement warranty.*
- *All audio equipment carries a depot repair / replacement warranty.*
- *All IVS accessories carry a depot repair / replacement.*
- *All wiring and installation labor carries a 90-day on-site warranty.*

IVS will make a best effort to validate warranty coverage of requested equipment repair by referencing the equipment serial number with the purchase date of the equipment. If IVS is unable to obtain warranty verification and you believe the equipment should be covered you may need to provide proof of purchase. All items returned must have a valid RMA number written on the box. An RMA number will only be provided after remote diagnostics are performed by an IVS technician. Items received without a valid RMA number may be returned to Customer at Customers expense.

### Optional On-Site Service Agreement

An on-site service agreement may be purchased from IVS at an additional cost. This will appear as a separate line item on the initial invoice as well as each yearly renewal invoice. If this service is purchased the component warranty changes from the above to the following:

- *All servers carry a 90-day replacement*
- *All servers carry an on-site warranty.*
- *All cameras carry an on-site warranty.*
- *All audio equipment carries an on-site warranty.*
- *All IVS accessories carry an on-site warranty.*
- *All wiring and installation labor carries an on-site warranty.*

On-site services are provided only after remote diagnostics are and a IVS technician determines that onsite services are required to correct the issue.

### Term

Warranty is included for all components from the date of invoice for a 5-year period. After the 5-year period components will be replaced and the material cost of the component will be billed to the customer. If the customer chooses to not renew the yearly SSA all hardware will revert to OEM manufacturer warranty and the customer will need to work directly with the component

manufacturers to obtain any related warranty services. IVS does not provide warranty services for products not provided by IVS.

**Warranty Exclusions**

IVS does not proactively monitor the health of customer systems. Any issues or concerns must be reported by the customer using the methods described in the “Obtaining Warranty Service” section below. The delivery of any warranty service provided by IVS does not cover problems attributed to the following:

- *Accident*
- *Abuse or misuse*
- *Problems with electrical power*
- *Servicing by unauthorized party*
- *Equipment not supplied by IVS*
- *Usage not in accordance with instructions*
- *3rd party software or operating systems*
- *Failure to perform preventative maintenance*
- *Customer related network issues*
- *Inadequate end user training or skills*
- *Physical damage caused by customer or 3<sup>rd</sup> party*
- *User data loss*
- *Acts of God or nature*
- *Damage incurred during shipping*

**Obtaining Warranty Service**

To request warranty services please contact Intelligent Video Solutions (IVS) by phone: 262-746-9290 #2 (monitored 7 am - 7 pm M-F CST) by email: [support@ipivs.com](mailto:support@ipivs.com) (monitored 7 am - 7 pm M-F CST) or using our support booking calendar: <https://ipivs.com/book>. Prior to sending a system in for service you should back up any data on the hard drives you wish to maintain. Any removable media should be removed from the system or device (do not remove the license key). If you are sending a system in for depot repair do not include any accessories with the system. IVS will not accept any liability for lost customer data or software. Any cost associated with lost data or reconstructing data stored on removable media will not be covered under this warranty.

**Warranty Disclaimers**

IVS makes no express or implied warranties beyond those stated in the warranty section. IVS disclaims all other warranties, express or implied, including without limitation implied warranties of merchantability and fitness for a particular purpose. Some states do not allow limitations on implied warranties. IVS’s responsibility for malfunctions and defects in hardware is limited to repair and replacement set forth in this warranty statement. IVS does not accept liability beyond the remedies set forth in this warranty statement or liability for incidental or consequential damages, including without limitation any liability for products not being available for use, additional customer time or labor associated with service, or for lost data or software.

## 6. Pricing

### **i. Specify all expenses in the estimation of cost**

Please see quote **2602111031JR** on page 47.

### **ii. Describe the scope of services it entails and any services which would not be covered or which would be provided for an additional charge**

Please see the line-item descriptions included in quote **2602111031JR** on page 47.

### **iii. Itemized list of cost for project including all hardware, software, software subscriptions, installation fee, shipping, vehicle charge and any other costs associated with project**

Please see quote **2602111031JR** on page 47.

### **iv. Warranty and additional warranty options**

Please see the **Hardware Warranty Statement** on page 44.

### **v. Service Calls**

If remote diagnostics by the IVS support technicians determine a service call is required, our support team will request a quote for a service call from the regional account management team. Your account management team will provide the Township with the quote for service to sign or provide a Purchase Order(PO). A service call may provide the following:

- Provide onsite troubleshooting for audio wiring.
- Testing, configuration, and troubleshooting of advanced audio solutions purchased from IVS.
- Replacement and configuration of equipment purchased from IVS.

**Intelligent Video Solutions**

N53 W24747 S. Corporate Circle

Sussex WI, 53089-0330

Phone: (855) 229-9699

Email: sales@ipivs.com

**SALES QUOTE****ADDRESS**1700 Ballard Road  
Park Ridge, IL 60068  
US**SHIP TO**1700 Ballard Road  
Park Ridge, IL 60068  
US

Quote Name	Created Date	Expiration Date
2602111031JR	Feb, 11 2026	May, 29 2026

Terms
Please visit: <a href="https://ipivs.com/support-information/#terms">https://ipivs.com/support-information/#terms</a>

Description	Quantity	Unit price	Total
<b>Richard Lyon - Maine Township</b> Small Child Therapy Space			
10149 T1A2S-K The T1A2S is a small form factor chassis featuring a single Intel Core Ultra 5 235 CPU, 14 (6P 8E) cores, and 16GB DDR5 of memory for up to 5 1080p cameras offering 1,000 hours of video storage.  Includes the VALT software base license.  Requires duplex power outlet; UPS (IVS best practice recommendation); one network connection, connected directly to the customer-provided PoE switch.	1	\$5,035.00	\$5,035.00
90010 SSA Warranty Support & Maintenance yearly contract <a href="#">See More</a>	1	\$1,350.00	\$1,350.00
<b>Session Room</b> Wall mounted Cameras and Mic. No access above board ceilings.  (Room Build: Sheetrock/Hard Ceilings)	1		
19033 P3275-K AXIS P3275-LV 2MP Indoor IP Dome Camera, 3.4-8.9mm Varifocal Lens. Includes AXIS T6101 Audio Module for dual Accessory support and Audio output to an in-room talkback system.	1	\$880.00	\$880.00
19034 P3275-K AXIS P3275-LV 2MP Indoor IP Dome Camera, 3.4-9.8mm Varifocal Lens	1	\$705.00	\$705.00
53011 VALT1E VALT Enterprise Camera License	2	\$3,000.00	\$6,000.00
39003 WAMIC-K Vandal Proof Wall Microphone & Mount Kit - Provides audio for up to 2 IP cameras <a href="#">See More</a>	1	\$280.00	\$280.00
39006 STDA3-K 3 Channel Audio Distribution Amp & 24VDC Power Supply for Sharing a Single Audio Source with up to 3 Cameras <a href="#">See More</a>	1	\$315.00	\$315.00
54007 VALTBPS-K Combination Privacy Button and Start/Stop Button <a href="#">See More</a>	1	\$300.00	\$300.00
		Room Total:	\$8,480.00
<b>Observation Room</b> Live observation audio with one-way glass (Room Build: Sheetrock/Hard Ceilings)	1		
39060 ORAS-K One wall speaker with volume control and one headphone jack with volume control; used for live audio when one way glass is used for live observation. Includes a 24 VDC power supply and wall mount kit.  Requires standard duplex power outlet near where the device will be located.  End user headphones to be sourced by customer. <a href="#">See More</a>	1	\$705.00	\$705.00
		Room Total:	\$705.00
<b>BEAM License for Mobile Recording</b>			

Description	Quantity	Unit price	Total
53011 VALT1E VALT Enterprise BEAM License - mobile recording on an ios device, such as an iPad or iPhone	1	\$3,000.00	\$3,000.00
<b>Professional Services</b> Includes installation, system configuration, training, travel and support.	1		
95012 SUBLAB Subcontracted Labor	1	\$3,816.00	\$3,816.00
95013 SUPVIS IVS Engineer provided to oversee installation and provide guidance to customer/integrator provided labor for up to one week.	1	\$954.00	\$954.00
95203 PROJM Project Management Services For VALT Deployment	1	\$540.00	\$540.00
96010 MCABL Combined cost of all low voltage power and audio cabling for the project.  Does not include network cabling.	1	\$60.00	\$60.00
95101 OCONF On Site Configuration Services of VALT Appliance(s) - Software & Axis Cameras <a href="#">See More</a>	1	\$420.00	\$420.00
95201 ONTNG On Site Training of VALT Software for users and administrators	1	\$500.00	\$500.00
95400 TRAVL Travel Expenses	1	\$1,800.00	\$1,800.00
96014 SHIPPING & LOGISTICS Shipping and Logistics	1	\$246.60	\$246.60

Estimate does not include any applicable sales tax that may be due.

Subtotal	<b>\$26,906.60</b>
<b>Total (USD)</b>	<b>\$26,906.60</b>

### Pricing

Thank you for the opportunity to serve you! Pricing is valid through the expiration date specified above. Changes to the quantities or items listed will require a revised quotation and may affect the final price. The pricing in this quote shall be adjusted in the case of unknown customer requirements such as removal of old equipment, local code mandates, performance bond or prevailing wage demands.

### Shipping

IVS will ship quoted product upon receipt of purchase order as available unless directed otherwise. Please note if the customer requests the equipment ship 180 days or more from the date the Purchase Order received, the customer will be invoiced a 5% holding fee at 180 days.

### Warranty and Support

Intelligent Video Solutions provides comprehensive warranty and software support for all products that we provide. For specific details on warranty, support, service level agreement and end user software license agreement please visit the following link on the IVS website: <https://ipivs.com/support-information/>

### Project Plan and Timeline

Intelligent Video Solutions and Customer will agree to a Project Plan and Timeline within 30 days after receipt of a purchase order. Any subsequent changes to the Project Plan may result in Change Orders and additional charges or credits. Once a Project Plan is agreed upon by Intelligent Video Solutions and the Customer, subsequent project milestone delays by the Customer may result in additional charges or overall project delays.

Customer is responsible for validating that any equipment quoted will operate within their infrastructure and policies. This includes server type, network switches, network drops, power, etc. Unless quoted, all network cabling required for project is the responsibility of the customer.

### Valid Reasons for a Return

We strive to exceed the expectations of our customers, and we understand sometimes changes need to be made that necessitate a return.

- Order cancellation
- Changes made to an order after shipment
- Defective equipment
- The solution does not meet the customer's expectations

### Hardware

Standard hardware may be returned within sixty (60) days of receipt by the customer if it is in new and resalable condition. The hardware must include the original packaging. Hardware returns are subject to a fifteen (15) percent restocking fee. Defective equipment is not subject to a restocking fee. Custom-ordered hardware may not be returned.

### Licenses

Description	Quantity	Unit price	Total
-------------	----------	------------	-------

Prior to installation and start of the Software Support Agreement, licenses may be returned for a full refund. After installation and start of the Software Support Agreement, licenses may only be returned if the solution does not meet the customer's expectations, and the issue is unable to be resolved by the IVS support team. Any such return requests must be made within ninety (90) days of the installation and start of the Software Support Agreement.

**Professional Services**

Professional services are not eligible for a refund after the services have been completed.

Thank you for purchasing VALT from Intelligent Video Solutions.

# **Proposal for Clinical Observation and Recording System**

## **Maine Township Youth & Family Services**

### **Submitted By:**

WSI Technologies

### **Solution:**

iRecord Recording System

### **Submission Date:**

3/18/26

### **Prepared For:**

Maine Township

Youth and Family Services

---

## **Table of Contents**

1. Executive Summary
2. WSI Technologies Overview
3. Project and Installation Plan
4. Project Team
5. Product Information
6. System Design Diagram
7. Equipment Listing
8. Permits and Compliance
9. Training
10. Service and Support
11. Warranty

---

## **1. Executive Summary**

WSI Technologies is pleased to submit this proposal to Maine Township Youth and Family Services for the implementation of a **Clinical Observation and Recording System** designed to support forensic interviews, counseling sessions, and supervised observation.

The proposed solution utilizes the **iRecord digital recording platform**, a purpose-built system used nationwide by child advocacy centers, law enforcement agencies, and social service organizations to securely capture, store, and manage interview recordings.

The system provides:

- High-definition video recording
- Professional audio capture
- Synchronized audio and video recordings
- Secure storage and controlled access
- Export capability for documentation and evidentiary use

WSI Technologies will provide a **turnkey solution**, including system design, equipment installation, configuration, testing, training, and ongoing technical support.

The proposed system is designed to provide Maine Township with a **reliable, easy-to-use, and secure recording platform** that supports professional documentation of interviews while maintaining strict access controls.

---

## 2.) Company Overview

WSI Technologies

WSI Technologies is a leading provider of public safety recording, evidence management, and communication solutions serving law enforcement agencies, 911 centers, and government organizations across the United States. The company specializes in the design, implementation, and support of mission-critical systems, including digital interview room recording, radio and telephony recording, and cloud-based evidence management platforms.

Company History and Experience

WSI Technologies has been in business for over 45 years and has established a strong reputation for delivering reliable, scalable solutions tailored to the needs of public safety agencies since 1977. The company has successfully deployed systems for a wide range of clients, including:

- Police departments

- Sheriff's offices
- 911 dispatch centers (PSAPs)
- Prosecutor's offices
- Child advocacy centers
- Municipal and county government agencies

WSI Technologies is an authorized partner and integrator of industry-leading platforms, including solutions from NICE, and has extensive experience implementing both on-premise and cloud-based recording systems.

#### Organization and Staffing:

WSI Technologies maintains a structured organization consisting of:

- Project Managers responsible for project coordination and client communication
- Solutions Engineers responsible for system design and technical architecture
- Field Technicians responsible for installation and system deployment
- Technical Support Specialists providing ongoing system support and maintenance

This team-based approach ensures that each project is delivered efficiently and meets the operational requirements of the client.

#### Scope of Services:

WSI Technologies provides comprehensive, end-to-end services, including:

- System design and consultation
- Equipment procurement and configuration
- On-site installation and integration
- System testing and commissioning
- End-user and administrative training
- Ongoing maintenance and technical support

These services are designed to ensure seamless implementation and long-term reliability of deployed systems.

#### Clients and Service Base:

WSI Technologies serves thousands of public sector clients across multiple states. The company's client base primarily consists of law enforcement and public safety organizations, with systems deployed in agencies of varying sizes—from small municipal departments to large county and regional operations.

Here is a list of three iRecord customers in Illinois. All have a similar scope to your project:

1. Sangamon County Child Advocacy Center: Denise Johnson  
(denise.johnson@sangamonil.gov)
2. Child Network: Brianne Hetman (bhetman@childnetwork.org)
3. Vermilion County Children's Advocacy Center: Jonathan Munoz  
(jmunoz@vercounty.org)

#### Financial Standing

WSI Technologies maintains a strong financial position and operates as a stable, growth-oriented organization. The company has a proven track record of successfully delivering projects on time and within budget, and it maintains long-term service relationships with its clients through recurring maintenance and support agreements.

#### Insurance Coverage

WSI Technologies maintains comprehensive insurance coverage consistent with industry standards for technology and public safety system integrators.

Proof of insurance is provided separately.

---

**No subcontractors will be used for this project**

---

### **3.) Project and Installation Plan**

WSI Technologies follows a structured project methodology to ensure successful deployment while minimizing disruption to operations.

#### **Project Initiation**

Following project approval:

- A project manager will be assigned
- Implementation scheduling will begin
- System requirements will be confirmed
- A project kickoff meeting may be scheduled with stakeholders

## **Design Review**

During this phase WSI Technologies will:

- Confirm room layouts and system design
- Verify network connectivity requirements
- Finalize camera and microphone placement
- Review installation logistics

## **Equipment Procurement and Preparation**

WSI Technologies will:

- Procure system hardware and components
- Configure the iRecord capture system
- Prepare equipment for deployment

## **On-Site Installation**

Installation activities include:

- Installation of HD cameras in interview rooms
- Installation of microphones for audio capture
- Installation of the iRecord capture system
- Network switch installation and connectivity
- Cabling and system integration

## **System Configuration and Testing**

Following installation the system will be configured and tested to ensure:

- Video capture functionality
- Audio capture clarity
- Synchronization of audio and video
- Recording storage functionality
- User access configuration

## **User Acceptance Testing**

Township personnel will verify system operation and confirm the solution meets operational requirements.

## **Training and System Activation**

Training will be provided to staff and the system will be placed into operational use.

Typical implementation timeline is **45–90 days from project approval**, depending on equipment delivery schedules and site coordination.

---

### **3. Project Team**

WSI Technologies assigns experienced personnel to each project to ensure a smooth and successful implementation.

#### **Project Manager: Patrick VanMeter**

The Project Manager serves as the primary point of contact and oversees all aspects of project execution.

Responsibilities include:

- Project scheduling
- Coordination with township staff
- Oversight of installation activities
- Communication of project status

#### **Solutions Engineer: Jim Cline**

The Solutions Engineer provides technical oversight and ensures the system design meets operational requirements.

Responsibilities include:

- System design validation
- Technical configuration
- Troubleshooting and support

#### **Field Technician: Keith Leuchter**

Field technicians perform on-site installation and system deployment.

Responsibilities include:

- Equipment installation
- Cabling and connectivity
- System testing

#### **Technical Support Team: Erik Thomas**

The WSI Technologies support team provides post-installation assistance and technical support.

---

## 4. Product Information

The proposed solution utilizes the **iRecord Digital Recording System**, designed specifically for forensic interview recording and observation environments.

The platform enables secure recording, management, and retrieval of interview sessions while maintaining strict access control.

### Key Features

#### High-Definition Video Recording

Multiple high-definition cameras capture interviews from different perspectives, providing a comprehensive visual record.

#### Professional Audio Capture

Interview room microphones capture clear audio to ensure accurate documentation of conversations.

#### Synchronized Recording

Audio and video recordings are automatically synchronized and stored as a single digital file.

#### Secure Storage

Recordings are stored within the iRecord system and can be accessed only by authorized users.

#### Recording Management

Users can:

- Search recordings
- Review interviews
- Manage stored recordings

#### Export Capability

Authorized users may export recordings for documentation, review, or evidentiary purposes when necessary.

---

## 5. System Design Diagram

The proposed system architecture includes interview room cameras and microphones connected to the central recording platform.

The design includes:

- Network-connected HD cameras
- Microphones connected to camera audio inputs
- Cameras connected to a dedicated camera network switch
- iRecord capture system connected to the township network

This design ensures reliable recording performance and secure access to recorded interviews.

*A detailed system diagram is included with this proposal:*

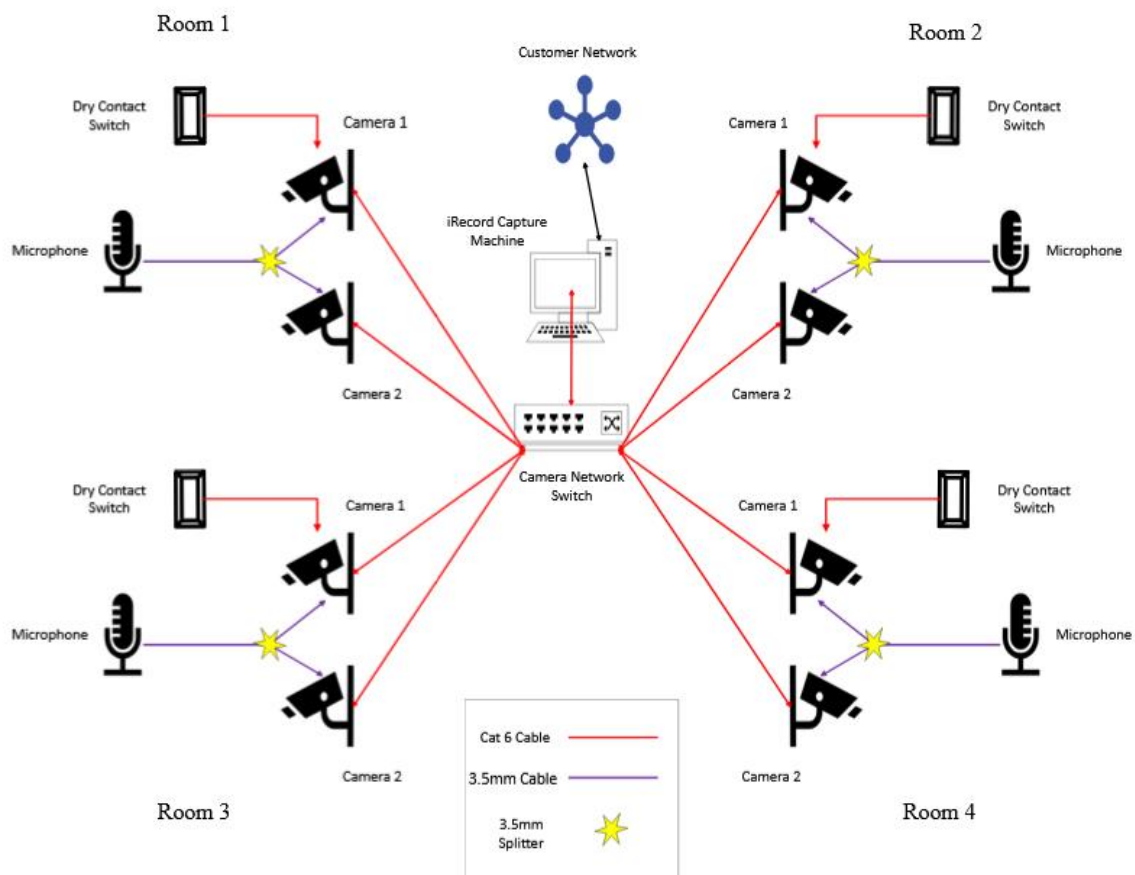

## 6. Equipment Listing

The proposed system includes the following equipment.

Equipment	Description	Quantity
iRecord Capture Unit	Digital interview recording server	1
Push Button	Start / stop device	2
HD Interview Cameras	High-definition cameras for interview rooms	3
Interview Room Microphones	Professional microphones for audio capture	2
Network Switch	Dedicated camera network switch	1
UPS	Power supply	1
Monitor	Viewing station	1
Speakers	Audio for viewing station	1
Cabling	Network and audio cabling	1

Full equipment specifications and pricing are provided in the accompanying quotation:

 				
<b>iRecord Digital Video/Audio Recording System for Interviews</b> Prepared For: Youth and Family Services at Maine Township Proposed Solution: iRecord Universe 2-Room System,3 Cameras 5-YR RTSA				
Prepared By: Caden Beckwith Date: 01-30-2026				
QTY	DESCRIPTION	PART #	UNIT PRICE	EXTENDED
<b>iRecord Software Licenses</b>				
2	iRecord Universe Software - Per Room (5 Year Term)	WSI-IR-Universe-S-Non-Inv	\$5,500.00	\$10,450.00
<b>iRecord Universe Capture Unit</b>				
1	iRecord Universe Capture Unit - Hardware: 1-4 Rooms w/ Secondary Capture Vault (Backup Storage)	IG WSI-IR-Capture-4RM	\$3,425.00	\$3,425.00
<b>iRecord Cameras</b>				
3	Dome - iRecord Capture Camera Kit (Axis)	IG WSI-IR-CAM-DOME	\$1,354.00	\$4,062.00
<b>iRecord Sensors and Microphones</b>				
2	Wallplate - iRecord Microphone Kit	WSI-AX-TU1001-V	\$265.00	\$530.00
<b>iRecord - Accessories</b>				
2	iRecord Universe - Push Button Switch	WSI-SM-SGSPL7-SS	\$99.00	\$198.00
<b>Capture Unit Add-ons</b>				
1	iRecord Camera Network Device - 16 Port	WSI-NG-GS116PP	\$495.00	\$495.00
1	Uninterruptible Power Supply - per Capture Station	WSI-UPS1000	\$455.00	\$455.00
1	22" Capture Station Monitor	WSI-MON22	\$375.00	\$375.00
1	Capture Unit Speakers	WSI-COMPSPKRS	\$59.00	\$59.00
<b>Years Annual Subscriptions and Maintenance</b>				
5	Pre-Paid: Remote Technical Support	M&S - iRecord - Remote	\$2,540.00	\$12,700.00
<b>Installation and Professional Services</b>				
1	On Site Professional Services Includes dedicated project management, part delivery, installation and training. <b>Excludes cable and cable installation</b>	WSI-Inst-On-Site-iRecord	\$4,500.00	\$4,500.00
1	3rd Party Wiring Services	WSI-Inst-Wiring Plus	\$1,150.00	\$1,150.00
1	Services - Travel and Expenses	T&E	\$1,203.00	\$1,203.00
			<b>1st YR Payment</b>	<b>\$29,442.00</b>
			<b>YR 2-5 Payment</b>	<b>\$2,540.00</b>

## 7. Permits and Compliance

The installation of the proposed system primarily involves **low-voltage equipment installation**, including cameras, microphones, and network cabling.

Typically, these installations **do not require building permits**, as no structural modifications are required.

As for additional compliance:

- Vendor is compliant with the Cook County prevailing Wage Act 820 ILCS 130/4
- Vendor assures compliance to be protected / encrypted both at rest and transit
- System is HIPAA compliant

If permit requirements are identified by local authorities, WSI Technologies will coordinate with Maine Township to ensure compliance with all applicable regulations.

---

## 8. Training

WSI Technologies provides comprehensive system training to ensure staff are comfortable operating the system.

Training includes:

### End User Training

- Starting and stopping recordings
- Reviewing recorded interviews
- Exporting recordings
- Managing recordings within the system

### Administrative Training

- User account management
- System settings
- Storage management

Training is typically delivered during system commissioning and may be conducted **virtually**.

---

## 9. Service and Support

WSI Technologies provides ongoing support for the iRecord system.

Support services include:

### **Technical Support**

Customers may contact the WSI Technologies support team for troubleshooting assistance and system questions.

### **Remote Diagnostics**

Many system issues can be resolved remotely through secure support tools.

### **On-Site Service**

If required, a technician can be dispatched to the site to resolve hardware or connectivity issues. Additional rate-sheet is required.

### **Support Hours**

Technical support is available 24 a day.

---

## **10. Warranty**

The proposed system includes warranty coverage as outlined in the **WSI Technologies Master Services Agreement**.

Warranty coverage includes:

- Manufacturer warranty on hardware components
- Technical support for system software
- Replacement of defective equipment in accordance with warranty terms

Extended service and maintenance agreements may also be available.

\*Terms and Conditions of service / support / warranty attached as supplemental documentation.

---



**iRecord Digital Video/Audio Recording System for Interviews**

Prepared For: Youth and Family Services at Maine Township

Prepared By: Caden Beckwith

Proposed Solution: iRecord Universe 2-Room System,3 Cameras 1-YR RTSA

Date: 03-17-2026

QTY	DESCRIPTION	PART #	UNIT PRICE	EXTENDED
<b>iRecord Software Licenses</b>				
2	iRecord Universe Software - Per Room (5 Year Term)	WSI-IR-Universe-S-Non-Inv	\$5,500.00	\$10,450.00
<b>iRecord Universe Capture Unit</b>				
1	iRecord Universe Capture Unit - Hardware: 1-4 Rooms w/ Secondary Capture Vault (Backup Storage)	IG WSI-IR-Capture-4RM	\$3,425.00	\$3,425.00
<b>iRecord Cameras</b>				
3	Dome - iRecord Capture Camera Kit (Axis)	IG WSI-IR-CAM-DOME	\$1,354.00	\$4,062.00
<b>iRecord Sensors and Microphones</b>				
2	Wallplate - iRecord Microphone Kit	WSI-AX-TU1001-V	\$265.00	\$530.00
<b>iRecord - Accessories</b>				
2	iRecord Universe - Push Button Switch	WSI-SM-SGSPL7-SS	\$99.00	\$198.00
<b>Capture Unit Add-ons</b>				
1	iRecord Camera Network Device - 16 Port	WSI-NG-GS116PP	\$495.00	\$495.00
1	Uninterruptible Power Supply - per Capture Station	WSI-UPS1000	\$455.00	\$455.00
1	22" Capture Station Monitor	WSI-MON22	\$375.00	\$375.00
1	Capture Unit Speakers	WSI-COMPSPKRS	\$59.00	\$59.00
<b>Years Annual Subscriptions and Maintenance</b>				
1	Pre-Paid: Remote Technical Support	M&S - iRecord - Remote	\$2,800.00	\$2,800.00
<b>Installation and Professional Services</b>				
1	On Site Professional Services Includes dedicated project management, part delivery, installation and training. <i>Excludes cable and cable installation</i>	WSI-Inst-On-Site-iRecord	\$4,500.00	\$4,500.00
1	3rd Party Wiring Services	WSI-Inst-Wiring Plus	\$1,150.00	\$1,150.00
1	Services - Travel and Expenses	T&E	\$1,203.00	\$1,203.00
			<b>System Total</b>	<b>\$29,702.00</b>

**Terms and Conditions**

This WSI Technologies Order ("Order") is made effective as of the date of Customer's signature below ("Order Effective Date") by and between Valsoft Corporation Inc. DBA WSI Technologies ("WSI") and the Customer identified below ("Customer"). WSI and Customer being sometimes collectively referred to herein as the "Parties," and individually, as a "Party."

- Scope and Applicability.** 1.1 **Hardware and Software.** Customer hereby agrees to purchase from WSI and WSI hereby agrees to, upon the terms and subject to the conditions contained in this order: (a) sell to Customer the room systems, cameras, microphones, accessories and other pieces of hardware identified above (the "Hardware"), and (b) grant to Customer a non-exclusive, non-transferable, fully paid license to access and use the object code of the software packages identified above including any modified, updated or enhanced versions of, or additional modules or content related to such software products (the "Software"). 1.2 **Services.** Customer hereby engages WSI to perform, and WSI hereby accepts such engagement to perform upon the terms and subject to the conditions of this Order, the installation services identified above (the "Installation Services") as well as any services related to the Hardware, Software, or maintenance and support of either, as more precisely identified above (collectively with the Installation Service, the "Services"). 1.3 **Contract Documents.** This Order is expressly governed by the Master Services Agreement (the "MSA"), and as applicable the Standard Scope of Work (the "SOW"), iRecord Nexus Agreement, iRecord Cloud Terms and Veritone Redact Terms (the "Additional Agreement(s)"), which are all incorporated herein by reference. In case of conflict, the Additional Agreement most closely related to the purchased Hardware, Software or Services shall govern with respect to that subject matter. For the purposes of this Order, the Order, MSA, SOW and Additional Agreements shall be collectively referred to as the "Contract Documents." 1.4 **Applicability.** By executing this Order, Customer acknowledges and agrees that the terms and conditions of this Order and the applicable Contract Documents shall govern the relationship between the Parties to the exclusion of all Customer provided terms and conditions. 1.5 **Terms.** The terms for any leased Hardware, Software license grant or support services shall be identified above next to the corresponding item.
- Fees and Payment.** 2.1 **Fees.** Customer agrees to pay the fees associated with the Hardware, Software and Services in the amounts set forth above as well as out-of-pocket expenses incurred by WSI in connection with the performance of its obligations under the Contract Documents (collectively, the "Fees"). 2.2 **Software Licenses Additional Fees.** If Customer's usage of the Software during the applicable period exceeds the usage limits set out in the applicable Order, WSI has the right to do any or all of the following: (i) automatically upgrade Customer's subscription tier for the next renewal License Term in accordance with Customer's actual usage; (ii) invoice Customer on a quarterly basis for the excess usage, which will be the difference between the prorated fees for the Software matching Customer's usage for the quarter and the prorated fees for the Software when used in accordance with the limits; and/or (iii) suspend access to, or cease providing the Software until such time as Customer's Software subscription tier is adjusted for Customer's actual usage. Customer acknowledges and agrees that WSI may monitor Customer's usage of the Software. 2.3 **Taxes.** The Fees are exclusive of taxes, and Customer will pay all taxes, if any, however designated, incurred in connection with, or as a result of, the Agreement or the license and receipt of Services, including state and local excise, sales, and use taxes paid or payable by WSI (except any tax based on WSI's net income). 2.4 **Payment.** Initially Fees shall be due and payable as follows: (i) 50% upon shipment and (ii) 50% upon system Installation. Installation means when the system is accessible and capable of performing according to its intended functionality. After Installation all Fees will be invoiced annually in advance at least sixty (60) days prior to the end of each 12-month period during the License Term, Support Term and/or Hardware Lease Term as applicable. Special payment terms and/or payment arrangements required under local law may be mutually agreed upon in a writing signed by the Parties. 2.5 **Payment Terms.** All Fees will be paid in US Dollars and will be due within thirty (30) days of receipt of the invoice for the same. With respect to any amount remaining unpaid after such 30-day period, in addition to any other rights it may have available, WSI may assess interest at a rate equal to the higher of: (i) one and one-half percent (1.5%) per month; or (ii) the highest rate allowed by law from the date that amount was due until the date of payment. Customer may not withhold or offset Fees for any reason. All Fees are fully earned and non-cancelable and all sums paid are non-refundable. WSI will have the right to increase Fees at renewal of the License Term, Support Term, and Hardware Lease Term, as applicable, and as otherwise set forth in the Contract Documents, including for factors such as computing costs, inflation, fuel costs, supply chain and third-party provider conditions, and Customer's usage history. Customer's obligation to pay amounts under the Contract Documents is absolute and unconditional. Failure to pay any Fees when due may result, at WSI's sole discretion, in suspension or termination of access to the Software, Services, and/or remote connectivity until full payment is received. 2.6 **Termination Fees.** If this Order is terminated, Customer shall pay Fees incurred through the later of: (a) the effective date of such termination, or (b) the date the other Party receives notice of such termination. As to any Fee to be paid by Customer for Installation Services performed by WSI Staff, if this Order is terminated, Customer will pay a reasonable and proportionate share of such Fee as determined by WSI based on Installation Services performed up to the later of the effective date of such termination or the date the other Party receives notice of such termination. If installation is not completed within 365 days of the Order Effective Date due to Customer delay, WSI may re-quote the Order and charge additional fees to complete the work.
- Delivery, Installation and Returns.** 3.1 **Delivery.** Please allow an estimated 60-90 days from the Order Effective Date (or date of first payment when applicable) for delivery. 3.2 **Installation.** Customer will notify WSI when Customer has completed Customer Responsibilities on which Installation Services are dependent. If WSI's technician identifies that Customer has not completed such Customer Responsibilities and as a result the technician cannot perform Installation Services, then the technician will have no obligation to perform the dependent Installation Services, and when Customer has completed the applicable Customer Responsibilities, WSI will deploy a technician to complete the dependent Installation Services and Customer will pay for such technician's work at WSI's then current rates. 3.3 **Returns.** Custom equipment orders may not be returned. Stock merchandise and accessories may be returned if in the original packaging; provided, however, that a restocking fee of not less than twenty-five percent (25%) or such greater restocking fee as determined by WSI's supplier is paid by customer.

4 **Miscellaneous.** 4.1 Counterparts. This Order may be executed in any number of counterparts, each of which will be deemed an original but all of which together will be deemed for all purposes to constitute one and the same instrument. 4.2 E-Signatures. Signatures transmitted and received via facsimile or other electronic means will be treated as original signatures for all purposes of this Order. 4.3 Validity. **This Order is only valid for 30 days** from "prepared by" date first written above.  
Please mail acceptance to WSI Technologies, 9045 River Road, Suite 125, FAX to (317) 544-2192 or email to your salesperson.

5 **12 Month Hardware Warranty.**

<b>Customer Signature:</b>		<b>PO#:</b>	
<b>Printed Name:</b>		<b>Date:</b>	
<b>Title:</b>			

**iRecord Digital Video/Audio Recording System for Interviews**

Prepared For: Youth and Family Services at Maine Township

Prepared By: Caden Beckwith

Proposed Solution: iRecord Universe 2-Room System,3 Cameras 5-YR RTSA

Date: 01-30-2026

QTY	DESCRIPTION	PART #	UNIT PRICE	EXTENDED
<b>iRecord Software Licenses</b>				
2	iRecord Universe Software - Per Room (5 Year Term)	WSI-IR-Universe-S-Non-Inv	\$5,500.00	\$10,450.00
<b>iRecord Universe Capture Unit</b>				
1	iRecord Universe Capture Unit - Hardware: 1-4 Rooms w/ Secondary Capture Vault (Backup Storage)	IG WSI-IR-Capture-4RM	\$3,425.00	\$3,425.00
<b>iRecord Cameras</b>				
3	Dome - iRecord Capture Camera Kit (Axis)	IG WSI-IR-CAM-DOME	\$1,354.00	\$4,062.00
<b>iRecord Sensors and Microphones</b>				
2	Wallplate - iRecord Microphone Kit	WSI-AX-TU1001-V	\$265.00	\$530.00
<b>iRecord - Accessories</b>				
2	iRecord Universe - Push Button Switch	WSI-SM-SGSPL7-SS	\$99.00	\$198.00
<b>Capture Unit Add-ons</b>				
1	iRecord Camera Network Device - 16 Port	WSI-NG-GS116PP	\$495.00	\$495.00
1	Uninterruptible Power Supply - per Capture Station	WSI-UPS1000	\$455.00	\$455.00
1	22" Capture Station Monitor	WSI-MON22	\$375.00	\$375.00
1	Capture Unit Speakers	WSI-COMPSPKRS	\$59.00	\$59.00
<b>Years Annual Subscriptions and Maintenance</b>				
5	Pre-Paid: Remote Technical Support	M&S - iRecord - Remote	\$2,540.00	\$12,700.00
<b>Installation and Professional Services</b>				
1	On Site Professional Services Includes dedicated project management, part delivery, installation and training. <i>Excludes cable and cable installation</i>	WSI-Inst-On-Site-iRecord	\$4,500.00	\$4,500.00
1	3rd Party Wiring Services	WSI-Inst-Wiring Plus	\$1,150.00	\$1,150.00
1	Services - Travel and Expenses	T&E	\$1,203.00	\$1,203.00
			<b>1st YR Payment</b>	<b>\$29,442.00</b>
			<b>YR 2-5 Payment</b>	<b>\$2,540.00</b>

**Terms and Conditions**

This WSI Technologies Order ("Order") is made effective as of the date of Customer's signature below ("Order Effective Date") by and between Valsoft Corporation Inc. DBA WSI Technologies ("WSI") and the Customer identified below ("Customer"). WSI and Customer being sometimes collectively referred to herein as the "Parties," and individually, as a "Party."

- Scope and Applicability.** 1.1 **Hardware and Software.** Customer hereby agrees to purchase from WSI and WSI hereby agrees to, upon the terms and subject to the conditions contained in this order: (a) sell to Customer the room systems, cameras, microphones, accessories and other pieces of hardware identified above (the "Hardware"), and (b) grant to Customer a non-exclusive, non-transferable, fully paid license to access and use the object code of the software packages identified above including any modified, updated or enhanced versions of, or additional modules or content related to such software products (the "Software"). 1.2 **Services.** Customer hereby engages WSI to perform, and WSI hereby accepts such engagement to perform upon the terms and subject to the conditions of this Order, the installation services identified above (the "Installation Services") as well as any services related to the Hardware, Software, or maintenance and support of either, as more precisely identified above (collectively with the Installation Service, the "Services"). 1.3 **Contract Documents.** This Order is expressly governed by the Master Services Agreement (the "MSA"), and as applicable the Standard Scope of Work (the "SOW"), iRecord Nexus Agreement, iRecord Cloud Terms and Veritone Redact Terms (the "Additional Agreement(s)"), which are all incorporated herein by reference. In case of conflict, the Additional Agreement most closely related to the purchased Hardware, Software or Services shall govern with respect to that subject matter. For the purposes of this Order, the Order, MSA, SOW and Additional Agreements shall be collectively referred to as the "Contract Documents." 1.4 **Applicability.** By executing this Order, Customer acknowledges and agrees that the terms and conditions of this Order and the applicable Contract Documents shall govern the relationship between the Parties to the exclusion of all Customer provided terms and conditions. 1.5 **Terms.** The terms for any leased Hardware, Software license grant or support services shall be identified above next to the corresponding item.
- Fees and Payment.** 2.1 **Fees.** Customer agrees to pay the fees associated with the Hardware, Software and Services in the amounts set forth above as well as out-of-pocket expenses incurred by WSI in connection with the performance of its obligations under the Contract Documents (collectively, the "Fees"). 2.2 **Software Licenses Additional Fees.** If Customer's usage of the Software during the applicable period exceeds the usage limits set out in the applicable Order, WSI has the right to do any or all of the following: (i) automatically upgrade Customer's subscription tier for the next renewal License Term in accordance with Customer's actual usage; (ii) invoice Customer on a quarterly basis for the excess usage, which will be the difference between the prorated fees for the Software matching Customer's usage for the quarter and the prorated fees for the Software when used in accordance with the limits; and/or (iii) suspend access to, or cease providing the Software until such time as Customer's Software subscription tier is adjusted for Customer's actual usage. Customer acknowledges and agrees that WSI may monitor Customer's usage of the Software. 2.3 **Taxes.** The Fees are exclusive of taxes, and Customer will pay all taxes, if any, however designated, incurred in connection with, or as a result of, the Agreement or the license and receipt of Services, including state and local excise, sales, and use taxes paid or payable by WSI (except any tax based on WSI's net income). 2.4 **Payment.** Initially Fees shall be due and payable as follows: (i) 50% upon shipment and (ii) 50% upon system Installation. Installation means when the system is accessible and capable of performing according to its intended functionality. After Installation all Fees will be invoiced annually in advance at least sixty (60) days prior to the end of each 12-month period during the License Term, Support Term and/or Hardware Lease Term as applicable. Special payment terms and/or payment arrangements required under local law may be mutually agreed upon in a writing signed by the Parties. 2.5 **Payment Terms.** All Fees will be paid in US Dollars and will be due within thirty (30) days of receipt of the invoice for the same. With respect to any amount remaining unpaid after such 30-day period, in addition to any other rights it may have available, WSI may assess interest at a rate equal to the higher of: (i) one and one-half percent (1.5%) per month; or (ii) the highest rate allowed by law from the date that amount was due until the date of payment. Customer may not withhold or offset Fees for any reason. All Fees are fully earned and non-cancelable and all sums paid are non-refundable. WSI will have the right to increase Fees at renewal of the License Term, Support Term, and Hardware Lease Term, as applicable, and as otherwise set forth in the Contract Documents, including for factors such as computing costs, inflation, fuel costs, supply chain and third-party provider conditions, and Customer's usage history. Customer's obligation to pay amounts under the Contract Documents is absolute and unconditional. Failure to pay any Fees when due may result, at WSI's sole discretion, in suspension or termination of access to the Software, Services, and/or remote connectivity until full payment is received. 2.6 **Termination Fees.** If this Order is terminated, Customer shall pay Fees incurred through the later of: (a) the effective date of such termination, or (b) the date the other Party receives notice of such termination. As to any Fee to be paid by Customer for Installation Services performed by WSI Staff, if this Order is terminated, Customer will pay a reasonable and proportionate share of such Fee as determined by WSI based on Installation Services performed up to the later of the effective date of such termination or the date the other Party receives notice of such termination. If installation is not completed within 365 days of the Order Effective Date due to Customer delay, WSI may re-quote the Order and charge additional fees to complete the work.
- Delivery, Installation and Returns.** 3.1 **Delivery.** Please allow an estimated 60-90 days from the Order Effective Date (or date of first payment when applicable) for delivery. 3.2 **Installation.** Customer will notify WSI when Customer has completed Customer Responsibilities on which Installation Services are dependent. If WSI's technician identifies that Customer has not completed such Customer Responsibilities and as a result the technician cannot perform Installation Services, then the technician will have no obligation to perform the dependent Installation Services, and when Customer has completed the applicable Customer Responsibilities, WSI will deploy a technician to complete the dependent Installation Services and Customer will pay for such technician's work at WSI's then current rates. 3.3 **Returns.** Custom equipment orders may not be returned. Stock merchandise and accessories may be returned if in the original packaging; provided, however, that a restocking fee of not less than twenty-five percent (25%) or such greater restocking fee as determined by WSI's supplier is paid by customer.

4 **Miscellaneous.** 4.1 Counterparts. This Order may be executed in any number of counterparts, each of which will be deemed an original but all of which together will be deemed for all purposes to constitute one and the same instrument. 4.2 E-Signatures. Signatures transmitted and received via facsimile or other electronic means will be treated as original signatures for all purposes of this Order. 4.3 Validity. **This Order is only valid for 30 days** from "prepared by" date first written above.  
Please mail acceptance to WSI Technologies, 9045 River Road, Suite 125, FAX to (317) 544-2192 or email to your salesperson.

5 **12 Month Hardware Warranty.**

<b>Customer Signature:</b>		<b>PO#:</b>	
<b>Printed Name:</b>		<b>Date:</b>	
<b>Title:</b>			

## WSI TECHNOLOGIES MASTER SERVICE AGREEMENT

This WSI Technologies Master Service Agreement (the “**Agreement**”) is made as of [\_\_\_\_], by and between **Valsoft Corporation Inc. DBA WSI Technologies (“WSI”)**, and the entity making purchases under this Agreement (“**Customer**”). WSI and Customer being sometimes collectively referred to herein as the “**Parties**,” and individually, as a “**Party**.”

The terms and conditions of this Agreement and the related Contract Documents govern any order submitted by Customer and signed by both Parties for the provision and purchase of the Hardware, Software and/or Services (each, an “**Order**”). By executing this Agreement, Customer acknowledges and agrees that the terms and conditions of this Agreement and the applicable Contract Documents shall govern the relationship between the Parties to the exclusion of all Customer provided terms and conditions.

### 1. **DEFINITIONS.** The following terms are used in the agreement:

- 1.1. “**Affiliate**” means any entity controlling, controlled by, or under common control with the subject Party (with the threshold for control requiring 50% ownership).
- 1.2. “**Authorized User**” means any individual who Customer permits (or whom Customer asks WSI to permit) to access the Services, including users of Third-Party Vendors. The Order may further define and apply additional restrictions and limitations on Authorized Users and Third-Party Vendors.
- 1.3. “**Confidential Information**” means any information or material in tangible or intangible form that: (i) relates to the business or operations of the disclosing Party or is reasonably considered to be confidential, proprietary, or otherwise sensitive to disclosing Party (whether or not it is marked as confidential or proprietary); (ii) the disclosing Party obtains from any third-party and which the disclosing Party treats as confidential or proprietary whether or not owned by the disclosing Party; or (iii) is marked as proprietary or confidential, including the terms of this Agreement.
- 1.4. “**Contract Documents**” means (i) this Agreement, (ii) the Order, (iii) any applicable Services Terms, and (iv) any document expressly incorporated into any of the documents set forth in subsection (i) through (iii).
- 1.5. “**Correction**” means a patch, workaround, or modification addressing the practical impact of an Error.
- 1.6. “**Credentials**” means usernames, passwords, codes, and tokens that WSI may provide to be used by Customer and its Authorized Users to access the Software.
- 1.7. “**Customer Contacts**” means individuals designated by Customer to submit Support Requests.
- 1.8. “**Customer Data**” means any and all data and information, including Subject Data and third-party data, and including text, graphics, photographs, audiovisual elements, music, illustrations, video, or other content provided to WSI by or on behalf of Customer for Processing, and any and all updates or modifications thereto, made by either Customer or WSI.
- 1.9. “**Customer Information Security Incident**” means: (i) loss or unauthorized use of Credentials; and (ii) the unauthorized acquisition, access, or use of the Services, System, or WSI Confidential Information, or any other systems, networks, devices, information, or content of WSI or its third-party providers.
- 1.10. “**Data Subject**” means Authorized Users and each individual in relation to whom the Services are used.
- 1.11. “**Documentation**” means the user documentation and any other operating, training, and reference manuals relating to the use of the Hardware or Software as supplied by WSI to Customer, as well as any derivative works thereof.
- 1.12. “**Error**” means any logic, programming, typographic, or similar error that causes a material failure in Software.
- 1.13. “**Fees**” means the amounts to be paid by Customer for the Services as set out in the applicable Order and all out-of-pocket expenses incurred by WSI in its performance of the agreement.
- 1.14. “**Hardware**” means the hardware and equipment provided by WSI to Customer as set out in the Order.
- 1.15. “**Hardware Lease Term**” means the term of the lease for Leased Hardware as set out in the Order.
- 1.16. “**Hardware Terms**” means the separate terms and conditions applicable to Hardware.
- 1.17. “**Intellectual Property Rights**” means all rights in and to any of the following, however constituted: trade secrets, patents, copyrights, trademarks, service marks, URLs, trade dress, brand features, know-how, moral rights, contract rights, code (executable, source and other), and similar rights of any type under the laws of any applicable governmental authority, or international treaty, including, without limitation, all applications and registrations relating to any of the foregoing.
- 1.18. “**iRecord Cloud Terms**” means the separate terms and conditions applicable to iRecord Cloud Powered by NICE Investigate.
- 1.19. “**Laws**” means all current and future state, local, and federal laws, codes, rules, regulations, orders, or requirements having the effect of law, including those relating to privacy, data privacy, data protection, trans-border data flow, and data security and confidentiality, including relating to biometric data, protected health information, and other sensitive data, and monitoring and personnel privacy, and any and all successor or supplemental laws relating thereto.
- 1.20. “**Nexus Terms**” means the separate terms and conditions applicable to iRecord Nexus.
- 1.21. “**Process**”, “**Processing**”, “**Processed**” means any operation or set of operations which is performed on data, whether or not by automated means, such as collection, recording, organization, structuring, storage, adaptation or alteration, retrieval, consultation, use, disclosure by transmission, dissemination or otherwise making available, alignment or combination, restriction, erasure or destruction.
- 1.22. “**Veritone Redact Terms**” means the separate terms and conditions applicable to Veritone Redact.
- 1.23. “**Representative(s)**” means a Party’s directors, officers, employees, contractors, subcontractors, agents, and other representatives, subject to any limitations set out in the applicable Order.

1.24. “**Services**” means, collectively, the Hardware, Software, installation services, Support, WSI Content, and other services identified in an Order to be provided by WSI.

1.25. “**Services Terms**” are the iRecord Nexus Terms, iRecord Cloud Terms, and Veritone Redact Terms.

1.26. “**Software**” means the object code of the software listed in an Order and any modified, updated, or enhanced versions of, or additional modules related to, such software that WSI provides to Customer either pursuant to the maintenance and support provisions or pursuant to an Order, as well as configurations, modifications and Documentation for such software products or the standard reports or templates withing such software..

1.27. “**Subject Data**” means all data, images, photographs, videos, recordings, and other information relating to Data Subjects.

1.28. “**Support**” means the support and training services set out in the Order, provided that if Customer has purchased Software Assurance or Support Agreement, then Support means the services provided by WSI under Software Assurance or Support Agreement.

1.29. “**Support Request**” means a request submitted by Customer Contacts via email to helpdesk@wsi-tech.com or by phone at 317-544-0499.

1.30. “**System**” is the collective reference to the Software, the computer servers owned, leased, or controlled by WSI, and other technology that together comprise the software as a service solution if provided by WSI to Customer.

1.31. “**Third-party Items**” means any software, hardware, services, applications, systems, materials, data, information, technology, or any other tool or item proprietary to or provided by, or on behalf of, a third-party.

1.32. “**Third-party Terms**” means terms and conditions additional to those set out in the Agreement that apply to Services, including without limitation the iRecord Cloud Terms and the Redact Terms.

1.33. “**WSI Content**” means any information, data, materials, software, files, text, graphics, photographs, audiovisual elements, music, illustrations, video, or other content available through the Software or which is otherwise provided by WSI, its Affiliates, or their licensors.

## 2. **SOFTWARE.**

2.1. **License Grant.** Subject to terms and conditions of the Contract Documents, including payment of Fees, WSI grants to Customer, and as applicable, Customer’s Authorized users, a limited, non-exclusive, non-sublicensable, non-transferable license to (i) use the Software locally and (ii) remotely access and use the Software through the System, in each case only during the applicable term set forth in the Order (the “**License Term**”) and solely for Customer’s internal business purposes (the “**License**”). Use of the Software is limited to the locations, number, and type of Authorized Users, license types, permitted purposes, and other limitations set out in the applicable Order. During the License Term, Customer is permitted to make a reasonable number of copies of the Software only for backup, archival, and business continuity purposes. Any other use or distribution of the Software or WSI Content, unless authorized in writing by WSI, is prohibited. For clarity, no perpetual licenses are granted under this Agreement.

2.2. **Third-Party Vendors.** WSI acknowledges and agrees that Customer may use certain third-party vendors for purposes of performing Customer’s internal business processes (“**Third-Party Vendors**”). Customer may include within its Authorized Users Third-Party Vendors that are not WSI’s direct competitors, subject to the following conditions: (i) Third-Party Vendors will access and use the Software solely for Customer’s internal business processing services; (ii) Customer will be fully responsible and liable for all acts and omissions of the Third-Party Vendors, including their access to and use of the Services; (iii) Customer will ensure its Third-Party Vendors comply with the terms and conditions of this Agreement, including without limitation, [Section 10](#); (iv) Customer will formally notify WSI of each Third-Party Vendor in advance of any access to or use by the Third-Party Vendor of the Software and will ensure that each such Third-Party Vendor uses its own unique Credentials as detailed in [Section 3.3](#); and (v) upon termination of its relationship with such Third-Party Vendor and/or upon termination of this Agreement, Customer will ensure that all access to the Software by such Third-Party Vendors immediately ceases.

2.3. **Use Restrictions.** Unless otherwise expressly authorized in this Agreement or the applicable Order, Customer will not, and will ensure that its Authorized Users will not: (i) modify, adapt, alter, translate, or create derivative works of the Software; (ii) except as reasonably necessary to use the Software as permitted under this Agreement, upload, merge, or host the Software with any other systems or technology (including third-party hosting systems), software, data, or programs without the prior written authorization of WSI; (iii) sublicense, resell, re-distribute, lease, rent, loan, disclose or otherwise transfer the Software (or any part thereof) to any third-party; (iv) reverse engineer, decompile, disassemble, or otherwise attempt to derive the source or object code of the Software (or any part thereof); (v) use the Software (or any part thereof) to provide any facility management, service bureau or similar services to third parties, provide any third-party consulting services, or permit third parties to remotely access and use the Software (or any part thereof); (vi) use the Software (or any part thereof) to develop a product line that is similar to the Software; (vii) create any comparative analyses of the Software (or any part thereof), by itself or relative to other similar technology; (viii) alter, distort, or remove any confidential, proprietary, copyright, trademark, trade secret, or patent legends from any copy of the Software (or any part thereof); (ix) publish or otherwise distribute Credentials other than to Authorized Users; or (x) otherwise use or copy the Software (or any part thereof) except as expressly allowed under this Agreement. Customer will ensure that all Authorized Users comply with this Agreement.

2.4. **Updates.** WSI may, but is not obligated to, provide corrections, new versions, and other enhancements, releases, revisions, or modifications to the applicable Software (“**Updates**”, which include derivative works of the foregoing). If WSI makes an Update generally available to its customers at no additional cost during the applicable License Term, then WSI will notify Customer and provide such Update to Customer, unless otherwise set out in the applicable Order. If WSI provides, or makes available, an Update,

Customer must fully implement and use the Update within a reasonable time, not to exceed 180 days from the date of first availability, unless otherwise agreed in writing. WSI disclaims and excludes all liability arising from or relating to the Services with respect to which Customer has not fully implemented, and is not using, any Update provided or made available by WSI. For certainty, WSI has no obligation to provide any Support for Software more than one (1) major release or three (3) minor releases behind the then most current version. **Major Release** means a new **release of Software** supported by Supplier that adds features and functionality improving overall Product performance, efficiency and/or usability, and designated by Supplier as a replacement for a Product. **Minor Release**, or point release, or dot release, is an update to existing software. A minor release is normally intended to fix bugs or so small changes or cleanups to software. **Patch releases** are intended for very small changes or bug fixes that do not disrupt the actual software functionality. Version schematic is as follows X.Y.Z (3.4.3) relates to major.minor.patch.

3. **THIRD-PARTY TERMS.** Customer acknowledges and agrees that additional Third-party Terms may apply to Services, and Customer will comply with such Third-party Terms.

4. **SERVICES.**

4.1. **Support.** Subject to payment of applicable Fees, WSI will provide Support during the License Term set out in the Order. Support includes: (i) remote or onsite technical assistance, (ii) response to Support Requests submitted by Customer Contacts, (iii) undertaking commercially reasonable efforts to resolve technical issues, including Error identification and corrections, (iv) and monitoring of hosted software infrastructure.

4.2. **Support Hours:** Support is provided during WSI’s business days and hours, generally Monday through Friday, 8 am-5 pm Eastern time. Support and Holiday schedule can be found on WSI’s Website. Extended or 24/7 support can be provided when purchased by Customer.

4.3. **Scope of Support.** Support includes telephone or remote assistance to Customer Contacts regarding the technical operation of Supported Products. Support does not include assistance with interpreting results, strategic planning, or unsupported third-party software.

4.4. **Support Exclusions.** Support does not include issues resulting from: (i) unauthorized actions of Customer or Service Providers, (ii) modified software or hardware (unless by WSI), (iii) unsupported operating environments, (iv) network, infrastructure, or other customer environment issues, (v) failure to install Corrections or Updates, (vi) Non-WSI provided hardware, (vii) and force majeure and other situations outside of WSI’s control. Services requested for issues arising from these exclusions or beyond the scope of purchased Support will be billed at WSI’s current hourly rates and are not subject to WSI’s support SLA.

4.5. **Additional Services.** Unless included in the Order, the following are time-and-material services: (i) annual health checks with executive summary, (ii) strategic technical consultation for business, (iii) additional training, (iv) management or support of third-party applications such as anti-virus software, (v) and OS updates or other system updates.

4.6. **Additional Resources.** Customer will have access to knowledge resources that WSI provides free of additional charge to all customers. Such resources may include technical documents, bulletins, webinars, user guides, and user group contact information.

4.7. **Customer Responsibilities.** Customer will provide reasonable cooperation to WSI in its provision of Support, including making applicable Hardware and Software accessible and available to WSI technicians within the time required by WSI.

5. **HARDWARE.**

5.1. **Hardware.** WSI will provide to Customer the Hardware, which may include either: (i) Hardware leased to Customer for the term identified in the Order (“**Leased Hardware**”); or (ii) Hardware purchased by Customer (“**Purchased Hardware**”). If Hardware is provided, the Hardware Terms will apply. For Leased Hardware, WSI hereby leases to Customer, and Customer hereby leases from WSI, the Leased Hardware for the term set forth in the Order (“**Lease Term**”). For Purchased Hardware, title to the Purchased Hardware (but not to any Software) will transfer to Customer at the time of delivery. The term “Hardware” includes the physical device(s) and the firmware included within the Hardware (“**Firmware**”). No right, title, or interest in the Firmware transfers to Customer, other than the limited right to use the Firmware as necessary to use the Hardware. All Use Restrictions in [Section 2.3](#) apply equally to the Firmware. Firmware and any feature keys are licensed for the corresponding License Term and cease upon its expiration or termination.

5.2. **Replacement Hardware.** If necessary, WSI will replace Hardware with identical or similar Hardware if the Hardware fails to operate in accordance with the manufacturer's specifications and operation instructions during the Warranty Term. Such replacement will be made as soon as practicable after Customer returns the non-conforming Hardware. If Customer has purchased applicable coverage, then Customer will return all non-conforming Hardware at WSI's expense to the destination specified by WSI. If Customer has not purchased applicable coverage, then all returns will be at Customer’s expense. If identical Hardware is not commercially reasonably available at the time of replacement, then WSI may use a compatible, alternate part or equipment. If WSI determines, acting reasonably, that Hardware is not commercially reasonably available for repair or replacement then Customer will be required to purchase a replacement part or equipment in order for WSI to perform its obligations.

5.3. **Warranty Term.** The warranty term (“**Warranty Term**”) for Hardware is set out in the order. The Warranty Term is measured from the date of delivery. WSI provides no warranty for Third-party Items, items provided by Customer.

5.4. **Warranty Exclusion.** Warranty does not apply in cases of misuse, environmental damage, unauthorized use, security incidents, or power disruptions. WSI disclaims responsibility for electrical or structural work.

**5.5. Damage or Loss; Return.** Customer is solely responsible for any Hardware that is lost, damaged, or destroyed while in Customer's possession or control. Upon expiration or termination of the applicable Hardware Lease Term, Customer will promptly return all Leased Hardware to WSI at Customer's sole expense and risk of loss. If Customer fails to return the Leased Hardware to WSI within thirty (30) days after any such termination, Customer hereby authorizes WSI to charge Customer for each piece of Leased Hardware not returned at WSI's then-current list prices.

**5.6. General Terms.** Customer is unconditionally obligated to pay all Fees and any other amounts due under the Agreement even if the Hardware is damaged or destroyed, is defective, or if Customer experiences temporary or permanent loss of use.

**6. PROPERTY OWNERSHIP.**

**6.1. WSI Proprietary Rights.** As between the Parties, WSI (or its licensors or providers) will retain ownership of all Intellectual Property Rights in the Services. Customer acknowledges and agrees that WSI may use, without restriction, all suggestions, improvements, and ideas concerning any part of the Services that may be communicated to WSI or its Representatives by Customer, Authorized Users, or Customer's Representatives. Promptly upon becoming aware, Customer agrees to inform WSI of any infringement, misappropriation, or violation of the Agreement with respect to the Services, or the Intellectual Property Rights therein.

**6.2. Customer Proprietary Rights.** As between the Parties, Customer (or its third-party suppliers) will retain ownership of all Intellectual Property Rights in Customer Data. Without the prior written approval of Customer, WSI will not use Customer Data for any purpose other than that of providing the Services, nor sell, assign, lease, or dispose of Customer Data, except as permitted under this Agreement or as expressly authorized by Customer. Customer accepts sole responsibility for errors in the Services to the extent resulting from inaccurate or incomplete Customer Data. Notwithstanding anything to the contrary herein, WSI has the right to use de-identified Customer Data for quality assurance purposes for improving its products and services.

**6.3. Rights Reserved.** Except as expressly set forth in this Agreement, no right or implied license or right of any kind is granted to Customer. Nothing in the Agreement confers upon either Party any right to use the other Party's trade names and trademarks except as necessary to exercise a license granted or to perform under the Agreement. All use of such marks, including all goodwill, by either Party will inure to the benefit of the owner of such marks.

**7. CUSTOMER OBLIGATIONS**

**7.1. Customer Obligations.** Customer agrees to timely perform all Customer obligations set out in the Agreement and/or as reasonably requested by WSI. Customer shall provide reasonable assistance and cooperation to WSI in its performance of the Services, including without limitation making applicable Hardware and Software accessible and available to WSI technicians within the time required by WSI. WSI will not be in breach of the Agreement if WSI is prevented or delayed in performing as a result of Customer's failure to comply with this [Section 7.1](#). Customer agrees that any such failure may also result in a reasonable adjustment to Fees, including any adjustments as are set out herein or in the Order.

**7.2. Data Backup: On-Premises Deployments.** For Software installed on Customer-owned infrastructure, Customer is solely responsible for implementing and maintaining appropriate data backup and protection measures. Unless Customer has separately purchased storage or backup services under an applicable Order, WSI shall have no responsibility for data loss, or for the reconstruction, replacement, repair, or re-creation of Customer Data or other systems on-premise.

**7.3. Data Backup: WSI-Hosted.** Data backup obligations and recovery terms are governed by the applicable solution-specific agreement purchased by Customer.

**8. SECURITY AND DATA PRIVACY**

**8.1. Security.** Customer will implement and maintain an up-to-date information security program reasonably designed to provide appropriate administrative, technical, and operational measures to prevent a Customer Information Security Incident. If Customer detects or reasonably suspects a Customer Information Security Incident has occurred or may occur, then Customer will promptly notify WSI thereof within twenty-four (24) hours of learning of such Customer Information Security Incident.

**8.2. Subject Data.** Customer is solely responsible for ensuring compliance with all applicable Laws regarding Customer Data. This includes, without limitation: (i) providing all legally required and industry-standard notices to Data Subjects; and (ii) obtaining all necessary and best practice consents from Data Subjects. Customer is solely liable for any failure to comply with these obligations.

**8.3. WSI Security Commitments.** WSI will maintain an information security program that includes administrative, technical, and physical safeguards designed to protect the confidentiality, integrity, and availability of Customer Data in its possession. If WSI detects or reasonably suspects information security incident has occurred, then WSI will promptly notify Customer thereof.

**9. FEES AND PAYMENT.**

Unless otherwise set out in the Order, Fees will be invoiced annually in advance. All Fees will be paid in US Dollars and will be due within thirty (30) days of receipt of the invoice for the same. With respect to any amount remaining unpaid after such 30-day period, in addition to any other rights it may have available, WSI may assess interest at a rate equal to the higher of: (i) one and one-half percent (1.5%) per month; or (ii) the highest rate allowed by law from the date that amount was due until the date of payment. Customer may not withhold or offset Fees for any reason. Fees are exclusive of taxes, and Customer will pay all taxes, if any, however designated, incurred in connection with, or as a result of, the Agreement or the license and receipt of Services, including state and local excise, sales, and use taxes paid or payable by WSI (except any tax based on WSI's net income). All Fees are fully earned and non-cancelable, and sums paid are non-refundable. WSI will have the right to increase Fees at renewal

of the License Term, Support Term, and Hardware Lease Term, as applicable, and as otherwise set forth in the Agreement, including for factors such as computing costs, inflation, fuel costs, supply chain and third-party provider conditions, and Customer's usage history. Customer's obligation to pay amounts under the Agreement is absolute and unconditional. Customer's obligation to pay amounts under the Agreement is absolute and unconditional. Failure to pay any Fees when due may result, at WSI's sole discretion, in suspension or termination of access to the Software, Support Services, and/or remote connectivity until full payment is received.

**10. CONFIDENTIAL INFORMATION.** Neither Party may use or disclose any Confidential Information of the other Party except in performing its obligations or exercising its rights under the Agreement (the "**Purpose**"). The receiving Party may only disclose Confidential Information of the disclosing Party to its Representatives and professional advisors that have a need to know such information in connection with the Purpose and who are bound by confidentiality obligations with respect to the disclosed Confidential Information no less stringent than those set out in this Agreement ("**Permitted Recipients**"). Customer shall, and shall cause its Permitted Recipients to, keep all Confidential Information in strict confidence and in no event will Customer or any of its Permitted Recipients disclose any Confidential Information of WSI, including the Services, to any third-party. Confidential Information does not include information or material that the receiving Party can demonstrate: (i) was in or enters the public domain (other than as a result of a breach of this Agreement or another obligation to the disclosing Party); (ii) was in the receiving Party's possession prior to its receipt from the disclosing Party without an obligation of confidentiality; (iii) is independently developed by the receiving Party without the use of or reference to the disclosing Party's Confidential Information; or (iv) is obtained by the receiving Party from a third-party under no known obligation of confidentiality to the disclosing Party. If a receiving Party becomes legally compelled to disclose any Confidential Information of the disclosing Party, such receiving Party will, if not prohibited by law, promptly notify the disclosing Party of the same prior to any disclosure so that the disclosing Party may, at its discretion, seek a protective order or other appropriate remedy, or waive compliance with these confidentiality terms. If such protective order or other remedy is not obtained, or if the disclosing Party waives compliance with these confidentiality provisions, then the receiving Party will disclose only that portion of the Confidential Information that it is legally required to be disclosed. The receiving Party acknowledges that disclosure of any Confidential Information or trade secret by it or by any person or entity to whom it discloses the disclosing Party's Confidential Information may give rise to irreparable injury to the disclosing Party or the owner of such information and that such injury will not be adequately compensated for by damages. The disclosing Party is liable for all use of Confidential Information by any person or entity to whom it discloses Confidential Information and for such individual or entity's compliance with this Section 10.

**11. WARRANTIES AND DISCLAIMERS**

**11.1. General Warranty.** Each Party represents and warrants that it is not subject to any agreement or obligation that would prevent it from complying with the Agreement. In its performance under the Agreement, WSI warrants that it will comply with applicable Laws. Customer warrants that it will comply with applicable Laws in its use of the Services and provision and use of Customer Data.

**11.2. Hardware Warranty.** WSI warrants the Hardware as set out in the Hardware Terms.

**11.3. Customer Warranty.** Customer represents and warrants that it has the right to use Customer Data (including third-party data and Subject Data) with and through the Services and to provide WSI with Customer Data (including third-party data and Subject Data) for use by WSI to perform under the Agreement.

**11.4. DISCLAIMER OF WARRANTIES.** OTHER THAN AS EXPRESSLY SET FORTH IN THIS AGREEMENT, NEITHER WSI, ITS AFFILIATES, LICENSORS OR SUPPLIERS, NOR THEIR SHAREHOLDERS OR REPRESENTATIVES, MAKES ANY EXPRESS OR IMPLIED WARRANTIES, CONDITIONS, OR REPRESENTATIONS TO CUSTOMER, ITS REPRESENTATIVES, OR ANY OTHER PERSON OR ENTITY WITH RESPECT TO THE SERVICES OR THE AGREEMENT, WHETHER ORAL OR WRITTEN, EXPRESS, IMPLIED OR STATUTORY, INCLUDING THE IMPLIED WARRANTY OR CONDITION OF MERCHANTABILITY, THE IMPLIED WARRANTY AGAINST INFRINGEMENT, AND THE IMPLIED WARRANTY OR CONDITION OF FITNESS FOR A PARTICULAR PURPOSE. WSI DOES NOT WARRANT THAT THE OPERATION OF THE SERVICES, OR ANY PRODUCTS OR RESULTS OF THE USE THEREOF, WILL MEET THE REQUIREMENTS OF CUSTOMER OR ANY OTHER PERSON OR ENTITY, OPERATE WITHOUT INTERRUPTION, ACHIEVE ANY INTENDED RESULT, BE COMPATIBLE OR WORK WITH ANY SOFTWARE, SYSTEM, OR OTHER SERVICES, OR BE SECURE, ACCURATE, COMPLETE, FREE OF HARMFUL CODE, OR ERROR FREE. EXCEPT FOR THE EXPRESS WARRANTIES SET FORTH IN THIS AGREEMENT, ALL SERVICES ARE PROVIDED "AS IS". IT IS THE RESPONSIBILITY OF CUSTOMER TO ASCERTAIN THE SUITABILITY OF THE SERVICES, AND ANY PRODUCTS OR RESULTS OF THE USE THEREOF, FOR ITS PURPOSES, AND ALL USE OF THE FOREGOING IS AT CUSTOMER'S SOLE RISK. WSI IS NOT RESPONSIBLE OR LIABLE TO CUSTOMER OR ANY OTHER PERSON OR ENTITY FOR ANY USE OR DISCLOSURE OF CUSTOMER DATA OR ANY PRODUCTS OR RESULTS OBTAINED FROM USE OF THE SERVICES. ALL THIRD-PARTY ITEMS ARE PROVIDED "AS IS" WITHOUT REPRESENTATION OR WARRANTY. CUSTOMER ACKNOWLEDGES THAT IT HAS NOT ENTERED INTO THE AGREEMENT IN RELIANCE UPON ANY WARRANTY OR REPRESENTATION NOT EXPRESSLY CONTAINED IN THIS AGREEMENT. FOR AVOIDANCE OF DOUBT, WSI WILL NOT BE RESPONSIBLE FOR PAYMENT OF ANY FINES OR PENALTIES ASSESSED AGAINST CUSTOMER, ITS AFFILIATES, OR CUSTOMER'S OR ITS AFFILIATES' REPRESENTATIVES BY ANY REGULATORY AUTHORITY FOR FAILURE OF CUSTOMER TO COMPLY WITH APPLICABLE LAWS.

**12. INDEMNIFICATION**

**12.1. General Indemnity.** In addition to obligations under Section 12.2 and Section 12.3, each Party (the "**Indemnifying Party**") will indemnify, defend, and hold harmless the other Party, its Affiliates, and the other Party's and its Affiliates' Representatives

(each, an “**Indemnified Party**”) against all third-party liabilities (including losses, damages, expenses and reasonable attorneys’ fees) to the extent arising from any claim brought by an unrelated third-party alleging injury, in whole or in part, resulting from the negligence or willful misconduct of the Indemnifying Party or its Representatives in connection with Services performed by WSI on Customer’s premises.

**12.2. WSI Indemnity.** WSI will indemnify, defend, and hold Customer harmless from and against any third-party claims, damages, actions, or proceedings that the Software, or Customer’s use thereof as permitted under this Agreement, infringes or misappropriates such third party’s valid U.S. patent, copyright, or trade secret (an “**IP Claim**”). If, in WSI’s reasonable judgment an IP Claim, or threat of an IP Claim, materially interferes with Customer’s use of the subject Software in accordance with the Agreement, WSI will consult with Customer, and WSI will have the option, in WSI’s sole discretion, to: (i) substitute functionally equivalent non-infringing software; (ii) modify the subject Software to make it non-infringing; (iii) obtain for Customer at WSI’s expense the right to continue using the infringing Software; or (iv) if the foregoing (i), (ii), or (iii) are not feasible in WSI’s sole discretion, WSI will notify Customer to cease using the subject Software, and WSI will refund a pro-rata portion of the Fees prepaid for the subject Software for such period of time during which Customer was unable to use the Software as a result of the IP Claim. WSI will have no indemnity obligation for IP Claims resulting or alleged to result from: (v) any Third-Party Items; (vi) any combination, operation, inclusion, or use of any Services with or in any Third-Party Items, except to the extent the IP Claim results from such action expressly permitted in the Documentation, if in WSI’s reasonable judgment the infringement or misappropriation would not have occurred but for such actions and the Third-Party Item; (vii) inclusion of Customer Data or Subject Data within the Software; (viii) any modification of the Software not expressly permitted by this Agreement by a person or entity (including Customer) if such infringement would have been avoided in the absence of such modifications; or (ix) the use of the Software in a manner other than for its intended purposes or contrary to the Documentation or the Agreement. This [Section 12.1.2](#) states WSI’s entire liability and Customer’s sole and exclusive remedy for infringement or misappropriation claims and actions.

**12.3. Customer Indemnity.** Customer will indemnify, defend, and hold WSI, its Affiliates, and their respective Representatives harmless from and against any third-party claims, damages, actions, or proceedings arising out of any third-party claim (which includes claims by Data Subjects) resulting from: (i) Customer Data; (ii) WSI’s Processing of Subject Data as permitted under the Agreement; (iii) Customer’s failure to comply with [Section 8.2](#); (iv) reliance on or use of any products or results from use of the Services by Customer, its Authorized Users, Third-Party Vendors, or Representatives; (v) Customer’s or Permitted Disclosees’ violation of WSI’s Intellectual Property Rights or other proprietary rights; or (vi) use of Third-Party Items by Customer, Authorized Users, or Representatives in combination with Services except to the extent such use is expressly permitted in the Documentation.

**12.4. General.** The defense and indemnification obligations set forth in this [Section 12](#) are conditioned upon: (i) the Indemnified Party providing the Indemnifying Party prompt notice of any claim or cause of action upon which the Indemnified Party intends to base a claim of indemnification hereunder; (ii) the Indemnified Party providing reasonable assistance and cooperation to enable the Indemnifying Party to defend the action or claim hereunder, at the Indemnifying Party’s expense; and (iii) the Indemnifying Party having sole control the defense and all related settlement negotiations, provided, however, that the Indemnified Party may, at its own cost, engage its own attorneys. The conditions set forth in this [Section 12.4](#) will not relieve the indemnifying Party from any liability under this [Section 12](#) except to the extent of actual prejudice.

**12.5. Settlement of Claims.** In connection with any obligation for indemnification under this Agreement the Indemnifying Party (i) may not settle any claim that results in the Indemnified Party’s liability without such Indemnified Party’s prior written consent, and (ii) will reasonably consult with the Indemnified Party during any settlement discussions.

### **13. LIMITATION OF LIABILITY**

**13.1. LIMITATION OF REMEDY.** EXCEPT TO THE EXTENT PROHIBITED BY LAW, IN NO EVENT WILL WSI OR ITS AFFILIATES OR THEIR RESPECTIVE LICENSORS, SUPPLIERS, SHAREHOLDERS, OR REPRESENTATIVES BE LIABLE TO CUSTOMER, ITS AFFILIATES, REPRESENTATIVES, OR ANY OTHER PERSON OR ENTITY, FOR ANY SPECIAL, INCIDENTAL, CONSEQUENTIAL, INDIRECT, EXEMPLARY, OR PUNITIVE DAMAGES OR LIABILITIES FOR ANY CAUSE WHATSOEVER ARISING OUT OF OR RELATING TO THE AGREEMENT, WHETHER IN CONTRACT OR TORT OR BY WAY OF INDEMNITY OR OTHERWISE, INCLUDING A BREACH THEREOF AND INCLUDING DAMAGES OR LIABILITIES FOR LOST PROFIT, LOST REVENUE, LOSS OF USE, LOSS OF GOODWILL, LOSS OF REPUTATION, REGULATORY FINES, LOSS OF DATA AND COSTS OF RECREATING LOST DATA, AND COST OF ANY SUBSTITUTE EQUIPMENT, SOFTWARE PROGRAM, OR DATA, REGARDLESS OF WHETHER THE POSSIBILITY OF SUCH DAMAGES OR LIABILITIES HAS BEEN COMMUNICATED TO WSI AND REGARDLESS OF WHETHER WSI HAS OR GAINS KNOWLEDGE OF THE EXISTENCE OF SUCH DAMAGES OR LIABILITIES. WSI WILL NOT BE LIABLE FOR ANY DAMAGES WHATSOEVER ARISING FROM CUSTOMER’S RELIANCE ON OR USE OF THE SERVICES, OR ANY PRODUCTS OR RESULTS FROM THE USE THEREOF.

**13.2. MAXIMUM LIABILITY.** EXCEPT FOR WSI’S INDEMNIFICATION OBLIGATIONS UNDER [SECTION 12.2](#), AND EXCEPT TO THE EXTENT PROHIBITED BY LAW, IN NO EVENT WILL WSI’S AGGREGATE LIABILITY UNDER THE CONTRACT DOCUMENTS FOR ALL CLAIMS AND ANY DAMAGES TO CUSTOMER, ITS AFFILIATES, AUTHORIZED USERS, SUBJECTS, OR ANY OTHER INDIVIDUAL OR ENTITY, REGARDLESS OF THE FORM OF ACTION, WHETHER BASED ON CONTRACT, TORT, NEGLIGENCE, STRICT LIABILITY, PRODUCTS LIABILITY, OR OTHERWISE, EVER EXCEED THE ACTUAL FEES RECEIVED BY WSI UNDER THE CONTRACT DOCUMENTS DURING THE TWELVE (12) MONTH PERIOD PRECEDING THE DATE ON WHICH THE FIRST CLAIM AROSE.

### **14. TERM; TERMINATION**

14.1. **Term.** This Agreement will continue until the termination or expiration of the last Order, unless earlier terminated as provided herein. Each License Term, a Support Term, and a Lease Term will automatically renew for additional periods of one (1) year unless either Party provides the other Party with written notice of non-renewal at least forty-five (45) days prior to the end of the applicable term. Fees for renewal terms will be invoiced sixty (60) days prior to the expiration of the License Term, Support Term, or Lease Term, as applicable.

14.2. **Termination for Breach.** If a Party materially breaches any provision of the Agreement and does not substantially cure such default, or commence and diligently pursue a cure, within thirty (30) days after being given written notice specifying the default, the non-defaulting Party may terminate the Agreement. Either Party may terminate this Agreement upon written notice to the other Party if all Orders and Statements of Work have expired or terminated.

14.3. **WSI Suspension and Termination Rights.** In addition to its rights under Section 14.1 (Termination for Breach), WSI has the right to: (i) suspend provision of Services upon a failure by Customer to pay Fees when due; (ii) suspend Customer's access to and use of the System as required by any third-party providing services necessary for WSI to provide the Services; (iii) suspend or terminate Customer's access and use of the Software upon an actual or threatened violation of Section 2.3 (Use Restrictions) or Section 8.2 (Subject Data); (iv) suspend Customer's access to the Software where WSI (or its licensors or suppliers) has a good-faith reason to believe that Customer is using the Software in a manner that may cause immediate and ongoing harm to WSI, its Affiliates, their respective Representatives, or WSI's licensors, suppliers, or any third-party, including actions that violate applicable Laws; and (v) terminate the provision of Software as a service upon termination of WSI's agreement (other than as the result of a default by WSI under such agreement) with any third-party provider providing services necessary for WSI to provide the System. WSI will have no liability for any suspension or termination under this Section 14.3, provided that any such action was made in good faith.

14.4. **Effect of Termination or Expiration.** Upon termination or expiration of the Agreement or any Order, all rights, Services, and licenses granted by WSI will immediately cease, and Customer shall promptly return or destroy all Confidential Information as instructed by WSI. Upon expiration or termination of a License Term, Customer will promptly cease all use, uninstall the Software, destroy any copies, and certify destruction in writing within ten (10) days of expiration or termination.

14.5. **Survival.** Termination or expiration of an Order will not impact the termination or expiration of a separate Order. Termination of an Order or this Agreement will not affect the survival of confidentiality obligations set out in this Agreement, indemnification and limitation of liability terms, Customer's payment obligations, and any other provisions that would be understood to survive a termination or expiration, all of which provisions will survive such termination or expiration.

**14.6. Post-Term Deactivation; Certification; Verification:**

14.6.1. **Technical Deactivation:** Upon any expiration or termination of the applicable License Term, Support Term, or Hardware Lease Term, or upon any suspension pursuant to Section 14.3, WSI may, without liability, remotely disable, deactivate, or otherwise technically restrict access to the System, Software, Firmware feature keys, and Credentials, and may require Customer to cease all use, uninstall, and destroy the Software. WSI's exercise of such rights will not limit or waive any other remedy available under the Agreement.

14.6.2. **Cessation and Certification.** Within ten (10) days after: (i) expiration or termination of the applicable term, or (ii) WSI's written request following a suspension for non-payment, Customer shall (A) cease all access to and use of the Services and Software, (B) uninstall and destroy all copies of the Software (including backup, archival, and disaster-recovery copies) in Customer's possession or control, and (C) deliver to WSI a written certification of cessation and destruction executed by an officer of Customer attesting to compliance with this Section 14.6.2.

14.6.3. **Limited Verification Right.** In addition to WSI's audit rights under 15.1, and solely to confirm compliance with Section 14.6.2, Customer will provide reasonable cooperation and information requested by WSI (e.g., system inventory reports, screenshots, de-activation logs). Any verification activities will be conducted during normal business hours, upon reasonable advance notice, and will not unreasonably disrupt Customer's operations.

14.6.4. **Reactivation.** If WSI suspends access for non-payment, WSI may condition any reactivation on: (i) receipt of all past-due amounts, (ii) payment of any applicable reinstatement or re-activation fees, and (iii) Customer's implementation of any Updates required by WSI.

**15. GENERAL**

15.1. **Audits.** WSI has the right to conduct reasonable audits of Customer's business operations to determine Customer's compliance with the Agreement. The Parties will work in good faith to resolve any non-compliance discovered in any such audit. If the Parties cannot reach a resolution and, in WSI's reasonable judgement, the non-compliance is material, WSI may terminate this Agreement and/or suspend the Services.

15.2. **Force Majeure.** Neither Party will be liable to the other for any delay or failure to perform (other than a failure of payment obligations) arising out of causes beyond its reasonable control, including technology interruptions or failures, government action, riots, epidemics, severe weather, acts of the other Party, fire, flood, terrorism, war, acts of the enemy, embargoes, work stoppages, labor disputes, or strikes. A Party will notify the other promptly upon learning of an event that may result in any delay or failure to perform. If a force majeure event occurs and continues to prevent substantial performance by the affected Party for more than sixty (60) days, either Party may terminate the impacted Order upon prior written notice to the other Party.

15.3. **Entire Agreement; Interpretation.** The applicable Contract Documents constitute the entire agreement between the Parties regarding the subject matter hereof and of all Orders and Scopes of Work hereunder, and supersedes all prior agreements,

negotiations, representations, and proposals, written or oral. No modifications, additions, or amendments to the Agreement will be effective unless made in writing and signed by duly authorized representatives of the Parties. As used herein, all references to the plural number will include the singular number and vice versa, and “includes” means “including without limitation”. Unless the context requires otherwise, “will”, “shall”, “will not”, and “shall not” are expressions of command, not merely expressions of future intent or expectation. All references to “days” will mean calendar days, unless stated otherwise.

15.4. **Assignment.** Customer will not assign or otherwise transfer the Agreement or any rights and obligations thereunder (by operation of law or otherwise) in whole or in part, and any such attempted assignment will be void and of no effect. The Agreement will be binding upon and inure to the benefit of the Parties, their legal representatives, and permitted transferees, successors, and assigns.

15.5. **Third-Party Beneficiaries.** Excluding WSI’s suppliers or vendors whose Third-party Terms apply pursuant to Section 3, there are no third-party beneficiaries to the Agreement and, in particular, but without limiting the generality of the foregoing, no Authorized Users (including Third-Party Vendors), Data Subjects, Permitted Recipients, any Customer Affiliate, or Customer’s or its Affiliates’ Representatives, will have any legal rights or entitlements of any kind hereunder under any circumstances.

15.6. **Waiver and Invalidity.** No delay or failure in exercising any right hereunder and no partial or single exercise thereof will be deemed to constitute a waiver of such right or any other rights hereunder. If any provision hereof is declared invalid by a court of competent jurisdiction, such provision will be ineffective only to the extent of such invalidity, so that the remainder of that provision and all remaining provisions of the Agreement will be valid and enforceable to the fullest extent permitted by applicable law.

15.7. **Choice of Law.** The Agreement will be exclusively construed, governed, and enforced in all respects in accordance with the internal laws of the State of Indiana.

15.8. **Export.** Customer will not dispose of any Services, know-how, technical data, documentation, or other materials furnished to it pursuant to the Agreement to any party or in any manner which would constitute a violation of applicable export control laws, including applicable laws of the United States.

15.9. **Notices.** Any and all notices permitted or required to be given hereunder will be deemed duly given upon actual delivery, if delivery is by hand or by reputable express courier. Each such notice must be sent to the respective Party at the address indicated in the Order or such other address of which the other Party is duly notified in accordance with this Section.

**Valsoft Corporation Inc. DBA WSI Technologies**

Customer: \_\_\_\_\_

**Signature:** \_\_\_\_\_

**Signature:** \_\_\_\_\_

**Name:** \_\_\_\_\_

**Name:** \_\_\_\_\_

**Title:** \_\_\_\_\_

**Title:** \_\_\_\_\_

**Date:** \_\_\_\_\_

**Date:** \_\_\_\_\_

This is to certify that the Policy(ies) of insurance listed below ("Policy" or "Policies") have been issued to the Named Insured identified below for the policy period(s) indicated. This certificate is issued as a matter of information only and confers no rights upon the Certificate Holder named below other than those provided by the Policy(ies).

Notwithstanding any requirement, term, or condition of any contract or any other document with respect to which this certificate may be issued or may pertain, the insurance afforded by the Policy(ies) is subject to all the terms, conditions, and exclusions of such Policy(ies). This certificate does not amend, extend, or alter the coverage afforded by the Policy(ies). Limits shown are intended to address contractual obligations of the Named Insured.

Limits may have been reduced since Policy effective date(s) as a result of a claim or claims.

<b>Certificate Holder:</b> Youth and Family Services at Maine Township 1700 Ballard Rd Park Ridge, IL 60068 Attn.: Richard Lyon, rlyon@mainetown.com	<b>Named Insured and Address:</b> Valsoft Corporation Inc. DBA WSI Technologies 9045 River Road Suite 125 Indianapolis, IN 46240
--	--

**This certificate is issued regarding:**

RFQ Request

Type(s) of Insurance	Insurer(s)	Policy Number(s)	Effective/Expiry Dates	Sums Insured Or Limits of Liability	
ERRORS & OMISSIONS	AIG Insurance Company of Canada	01-590-26-21	Jun 20, 2025 to Jun 20, 2026	Each Claim and in the Aggregate	USD 5,000,000
CYBER LIABILITY • Insurance afforded by the Policy(ies) stated herein is subject to the limits, Deductibles, Self-Insured Retention(s), exclusions, terms, and conditions of such Policies.	AIG Insurance Company of Canada	01-590-26-21	Jun 20, 2025 to Jun 20, 2026	Each Claim and in the Aggregate	USD 5,000,000
EXCESS CYBER LIABILITY • 1st Excess Liability	Lloyd's Underwriters	B1820LNR25C238	Jun 20, 2025 to Jun 20, 2026	Each Claim and in the Aggregate	USD 5,000,000
EXCESS CYBER LIABILITY • 2nd Excess Liability	Zurich Insurance Company Ltd	8624136	Jun 20, 2025 to Jun 20, 2026	Limit of Liability	USD 5,000,000

**Additional Information:**

Insurance afforded by the Policy(ies) stated herein is subject to the limits, Deductibles, Self-Insured Retention(s), exclusions, terms, and conditions of such Policies.

**Notice of cancellation:**

The insurer(s) affording coverage under the policies described herein will not notify the certificate holder named herein of the cancellation of such coverage.

<b>Marsh Canada Limited</b> 1 Place Ville-Marie, Suite 1500 Montreal, QC H3B 2B5 montrealcert@marsh.com	Marsh Canada Limited   By: _____ Jordi Montblanch
--	--



4/28/26

---

**TO:** Elected Officials

**FROM:** Victoria Rizzo, Administrator

---

**SUBJECT:** WASTE HAULER

---

- Discussion of Solid Waste Collection and Recycling Services

Maine Township is accepting proposals for residential solid waste collection, recycling services, landscape waste collection and disposal, and resident billing services for those living in the unincorporated areas of the Township. Sealed proposals must be submitted no later than May 15, 2026, and will be reviewed at the Board meeting on May 26, 2026. Residents are encouraged to attend the May meeting and provide input during the public participation portion for the Board's consideration.

**REQUEST FOR PROPOSAL**

**SOLID WASTE COLLECTION AND RECYCLING SERVICES**

**April 8, 2026**

**BY ORDER OF:  
KIMBERLY JONES  
SUPERVISOR**

## **TABLE OF CONTENTS**

**SECTION A    GENERAL INFORMATION**

**SECTION B    SPECIFICATIONS**

**SECTION C    MAP OF THE PROPOSED SERVICE AREA AND STREET INDEX**

**SECTION D    SUBMISSION INSTRUCTIONS**

**SECTION E    PROPOSAL FORM**

**SECTION F    SAMPLE CONTRACT**

## **SECTION A: General Information**

Maine Township's boundaries contain portions of Des Plaines, Glenview, Morton Grove, Niles, Park Ridge and Rosemont. The Township also contains unincorporated portions in Des Plaines, Glenview and Niles. Housing in the unincorporated area consists primarily of single-family buildings, townhomes/row houses, condominiums and apartment buildings.

An Ordinance was adopted on September 28, 2004 by the Maine Township Supervisor and Board of Trustees determining that an Exclusive Solid Waste and Recycling Franchise for single -family and multi-family buildings (defined as townhomes/row houses of eight (8) units or less) in the unincorporated area of Maine Township would be in the best interest of both the Township and its residents. Condominiums and apartment buildings are not included in the aforesaid Ordinance nor are these buildings included in this RFP.

## SECTION B: SERVICE SPECIFICATIONS

The selected Hauler, under all collection alternatives, shall collect solid waste, recyclables and landscape waste curbside at least once per week from all single-family households. Collection of solid waste, recyclables and landscape waste from townhomes/row houses shall be at least once per week either curbside where such units are suited for curbside collection or in other areas where feasible, such as an alley.

Term: The Township is requesting proposals for a term of 4 years, 5 years and 7 years to determine the term length that is in the best interest of both the Township and its residents.

The contract will commence on October 1, 2026 and terminate respectively on September 30, 2030 (4 year selection) September 30, 2031 (5 year selection) or September 30, ~~Am~~ 2033 (7 year selection).

**1.0 Single-Family Solid Waste Collection and Disposal with Cart:** The selected Hauler shall collect solid waste from single-family households once a week and shall be responsible for purchasing, delivering and maintaining the carts over the term of the contract. The Township is also requesting the price with a senior discount.

**2.0 Multi-Family Solid Waste Collection and Disposal with Cart:** The selected Hauler shall collect solid waste from multi-family households (defined as townhomes/row houses with eight (8) units or less) once a week and shall be responsible for purchasing, delivering and maintaining the carts over the term of the contract. The Township is also requesting the price with a senior discount.

**3.0 Recycling Services:** The selected Hauler shall collect at the curb once a week and process recyclable materials set out by the residents. The Township is seeking proposals for the collection of recyclables with the Hauler being responsible for providing carts or collection bins. The Township is also requesting the price with a senior discount.

**4.0 Landscape Waste Collection:** The selected Hauler shall collect all landscape waste once a week. All landscape materials shall be placed in biodegradable paper yard waste bags not exceeding fifty (50) pounds in weight or in bundles securely tied not exceeding five feet in length, two feet in diameter and fifty (50) pounds in weight. Each yard waste bag and bundle shall have one sticker affixed. Stickers will be provided to the Township by the selected Hauler and will be available for purchase from the Township only. Landscape waste shall be collected during the period from April 1<sup>st</sup> through December 15<sup>th</sup>.

**5.0 White Goods Collection:** The selected Hauler shall collect White Goods as defined in Section 22.28 of the Illinois Environmental Protection Act on the same day as solid waste is collected from the resident and the Hauler shall propose the price thereof.

**6.0 Bulk Items Collection:** The selected Hauler shall collect one household/bulk item per week free of charge from the resident and the Hauler shall propose the price thereof.

**7.0 Educational Component:** The selected Hauler shall offer educational hours for community/events on recycling and sustainability awareness.

**8.0 Contingencies for Termination:** The contract shall include a clause allowing the Township to terminate the Agreement prior to its expiration.

**9.0 Billing Information:** The selected Hauler shall bill all residents directly for the services provided. The selected Hauler will also be solely responsible for collecting all fees billed directly to residents. The Township is requesting a rebate on a quarterly basis based on the previous quarter's collected revenue for curbside and dumpster refuse and recycling collection. This rebate is to be mailed directly to the Township.

**SECTION C: Map of the Proposed Service Area (last page)**

## **SECTION D: Submission Instructions**

An intent to submit must be emailed to Administrator Victoria Rizzo at [vrizzo@mainetown.com](mailto:vrizzo@mainetown.com) by May 15, 2026. All questions should be emailed to [vrizzo@mainetown.com](mailto:vrizzo@mainetown.com), and the questions and answers will be shared with those who have submitted their intent respond to the proposal.

Please provide a brief history of your company, including how long you have been in business, your insurance coverage and how many municipalities and/or government agencies you serve.

Proposals in a signed and sealed envelope must be submitted no later than 9:30 a.m. on May 15, 2026, addressed to:

Clerk Peter Gialamas  
Town of Maine  
1700 Ballard Rd.  
Park Ridge, Illinois 60068

Proposals will be accepted in person at the Clerk's Office at the above address Monday through Friday between the hours of 9:00 a.m. and 5:00p.m.

## **SECTION E: EVALUATION CRITERIA**

This RFP is an invitation to submit a proposal and does not commit the Township to choose any Respondent or enter a contract with any entity. Each Respondent is responsible for its own costs of responding, of the proposal review process, and of the contracting process.

The Township reserves the right to:

- refuse any proposal which does not substantially comply with the service requirements
- reject any proposal with or without cause and without explaining the rejection
- cancel the proposal process
- negotiate a Contract with any, all, or none of the Respondents

The Township reserves the right to meet with each Respondent, inspect Respondent's facilities and equipment, and observe Respondent's operations.

After the selection process has ended, all proposals and any supporting documentation and materials submitted will be public information and made available in accordance with the Illinois Freedom of Information Act. If a Respondent believes any document or material is exempt from disclosure under the Freedom of Information Act (5 ILCS 140/1, et seq.), it may inform the Township in writing of the exact document and/or material and the applicable exemption. The Township, however, retains sole discretion over any response for records it receives under the

Act.

In evaluating each proposal, in addition to the cost of services, the Township will examine each Respondent's:

1. Ability, capacity and skill to perform the Service;
2. Character, integrity, reputation, judgment, experience and efficiency; and
3. Financial resources and ability to provide the service.

The Township is looking for a provider who is well-equipped, competent, and experienced in the provision of like hauling services, with a good reputation in the surrounding area, and whose proposal is most advantageous to Township residents. Although price is a factor in evaluating the proposal, the contract will not necessarily go to the lowest proposal.

The selected Hauler shall warrant and guarantee that their proposed pricing is firm and that there will be no escalation of cost or price at the time of contract.

**SECTION E: Maine Twp. RFP for Solid Waste Collection & Recycling Services Proposal Form**

Please specify the percentage of the quarterly rebate:
--

Four (4) Year Option

		YEAR 1	
1.0	Single-Family Solid Waste Collection & Disposal w/ cart	\$	Household/month
	Price with Senior Discount	\$	Household/month
2.0	Multi-Family Solid Waste Collection & Disposal w/cart	\$	Household/month
	Price with Senior Discount	\$	Household/month
3.0	Recycling Service (Carts or Collection Bins)	\$	Household/month
	Price with Senior Discount	\$	Household/month
4.0	Landscape Waste Collection (Price of sticker per bag or bundle)	\$	
5.0	White Goods Collection	\$	Per Item
6.0	Bulk Items Collection (first item free)	\$	Per item
		YEAR 2	
1.0	Single-Family Solid Waste Collection & Disposal w/ cart	\$	Household/month
	Price with Senior Discount	\$	Household/month
2.0	Multi-Family Solid Waste Collection & Disposal w/cart	\$	Household/month
	Price with Senior Discount	\$	Household/month
3.0	Recycling Service (Carts or Collection Bins)	\$	Household/month
	Price with Senior Discount	\$	Household/month
4.0	Landscape Waste Collection (Price of sticker per bag or bundle)	\$	
5.0	White Goods Collection	\$	Per Item
6.0	Bulk Items Collection (first item free)	\$	Per item
		YEAR 3	
1.0	Single-Family Solid Waste Collection & Disposal w/ cart	\$	Household/month
	Price with Senior Discount	\$	Household/month

2.0	Multi-Family Solid Waste Collection & Disposal w/cart	\$	Household/month
	Price with Senior Discount	\$	Household/month
3.0	Recycling Service (Carts or Collection Bins)	\$	Household/month
	Price with Senior Discount	\$	Household/month
4.0	Landscape Waste Collection (Price of sticker per bag or bundle)	\$	
5.0	White Goods Collection	\$	Per Item
6.0	Bulk Items Collection (first item free)	\$	Per item
		YEAR 4	
1.0	Single-Family Solid Waste Collection & Disposal w/ cart	\$	Household/month
	Price with Senior Discount	\$	Household/month
2.0	Multi-Family Solid Waste Collection & Disposal w/cart	\$	Household/month
	Price with Senior Discount	\$	Household/month
3.0	Recycling Service (Carts or Collection Bins)	\$	Household/month
	Price with Senior Discount	\$	Household/month
4.0	Landscape Waste Collection (Price of sticker per bag or bundle)	\$	
5.0	White Goods Collection	\$	Per Item
6.0	Bulk Items Collection (first item free)	\$	Per item

Five (5) Year Option

		YEAR 1	
1.0	Single-Family Solid Waste Collection & Disposal w/ cart	\$	Household/month
	Price with Senior Discount	\$	Household/month
2.0	Multi-Family Solid Waste Collection & Disposal w/cart	\$	Household/month
	Price with Senior Discount	\$	Household/month
3.0	Recycling Service (Carts or Collection Bins)	\$	Household/month
	Price with Senior Discount	\$	Household/month
4.0	Landscape Waste Collection (Price of sticker per bag or bundle)	\$	
5.0	White Goods Collection	\$	Per Item

6.0	Bulk Items Collection (first item free)	\$	Per item
		YEAR 2	
1.0	Single-Family Solid Waste Collection & Disposal w/ cart	\$	Household/month
	Price with Senior Discount	\$	Household/month
2.0	Multi-Family Solid Waste Collection & Disposal w/cart	\$	Household/month
	Price with Senior Discount	\$	Household/month
3.0	Recycling Service (Carts or Collection Bins)	\$	Household/month
	Price with Senior Discount	\$	Household/month
4.0	Landscape Waste Collection (Price of sticker per bag or bundle)	\$	
5.0	White Goods Collection	\$	Per Item
6.0	Bulk Items Collection (first item free)	\$	Per item
		YEAR 3	
1.0	Single-Family Solid Waste Collection & Disposal w/ cart	\$	Household/month
	Price with Senior Discount	\$	Household/month
2.0	Multi-Family Solid Waste Collection & Disposal w/cart	\$	Household/month
	Price with Senior Discount	\$	Household/month
3.0	Recycling Service (Carts or Collection Bins)	\$	Household/month
	Price with Senior Discount	\$	Household/month
4.0	Landscape Waste Collection (Price of sticker per bag or bundle)	\$	
5.0	White Goods Collection	\$	Per Item
6.0	Bulk Items Collection (first item free)	\$	Per item
		YEAR 4	
1.0	Single-Family Solid Waste Collection & Disposal w/ cart	\$	Household/month
	Price with Senior Discount	\$	Household/month
2.0	Multi-Family Solid Waste Collection & Disposal w/cart	\$	Household/month
	Price with Senior Discount	\$	Household/month
3.0	Recycling Service (Carts or Collection Bins)	\$	Household/month
	Price with Senior Discount	\$	Household/month

4.0	Landscape Waste Collection (Price of sticker per bag or bundle)	\$	
5.0	White Goods Collection	\$	Per Item
6.0	Bulk Items Collection (first item free)	\$	Per item
		YEAR 5	
1.0	Single-Family Solid Waste Collection & Disposal w/ cart	\$	Household/month
	Price with Senior Discount	\$	Household/month
2.0	Multi-Family Solid Waste Collection & Disposal w/cart	\$	Household/month
	Price with Senior Discount	\$	Household/month
3.0	Recycling Service (Carts or Collection Bins)	\$	Household/month
	Price with Senior Discount	\$	Household/month
4.0	Landscape Waste Collection (Price of sticker per bag or bundle)	\$	
5.0	White Goods Collection	\$	Per Item
6.0	Bulk Items Collection (first item free)	\$	Per item

Seven (7) Year Option

		YEAR 1	
1.0	Single-Family Solid Waste Collection & Disposal w/ cart	\$	Household/month
	Price with Senior Discount	\$	Household/month
2.0	Multi-Family Solid Waste Collection & Disposal w/cart	\$	Household/month
	Price with Senior Discount	\$	Household/month
3.0	Recycling Service (Carts or Collection Bins)	\$	Household/month
	Price with Senior Discount	\$	Household/month
4.0	Landscape Waste Collection (Price of sticker per bag or bundle)	\$	
5.0	White Goods Collection	\$	Per Item
6.0	Bulk Items Collection (first item free)	\$	Per item
		YEAR 2	
1.0	Single-Family Solid Waste Collection & Disposal w/ cart	\$	Household/month
	Price with Senior Discount	\$	Household/month

2.0	Multi-Family Solid Waste Collection & Disposal w/cart	\$	Household/month
	Price with Senior Discount	\$	Household/month
3.0	Recycling Service (Carts or Collection Bins)	\$	Household/month
	Price with Senior Discount	\$	Household/month
4.0	Landscape Waste Collection (Price of sticker per bag or bundle)	\$	
5.0	White Goods Collection	\$	Per Item
6.0	Bulk Items Collection (first item free)	\$	Per item
		YEAR 3	
1.0	Single-Family Solid Waste Collection & Disposal w/ cart	\$	Household/month
	Price with Senior Discount	\$	Household/month
2.0	Multi-Family Solid Waste Collection & Disposal w/cart	\$	Household/month
	Price with Senior Discount	\$	Household/month
3.0	Recycling Service (Carts or Collection Bins)	\$	Household/month
	Price with Senior Discount	\$	Household/month
4.0	Landscape Waste Collection (Price of sticker per bag or bundle)	\$	
5.0	White Goods Collection	\$	Per Item
6.0	Bulk Items Collection (first item free)	\$	Per item
		YEAR 4	
1.0	Single-Family Solid Waste Collection & Disposal w/ cart	\$	Household/month
	Price with Senior Discount	\$	Household/month
2.0	Multi-Family Solid Waste Collection & Disposal w/cart	\$	Household/month
	Price with Senior Discount	\$	Household/month
3.0	Recycling Service (Carts or Collection Bins)	\$	Household/month
	Price with Senior Discount	\$	Household/month
4.0	Landscape Waste Collection (Price of sticker per bag or bundle)	\$	
5.0	White Goods Collection	\$	Per Item
6.0	Bulk Items Collection (first item free)	\$	Per item
		YEAR 5	

1.0	Single-Family Solid Waste Collection & Disposal w/ cart	\$	Household/month
	Price with Senior Discount	\$	Household/month
2.0	Multi-Family Solid Waste Collection & Disposal w/cart	\$	Household/month
	Price with Senior Discount	\$	Household/month
3.0	Recycling Service (Carts or Collection Bins)	\$	Household/month
	Price with Senior Discount	\$	Household/month
4.0	Landscape Waste Collection (Price of sticker per bag or bundle)	\$	
5.0	White Goods Collection	\$	Per Item
6.0	Bulk Items Collection (first item free)	\$	Per item
		YEAR 6	
1.0	Single-Family Solid Waste Collection & Disposal w/ cart	\$	Household/month
	Price with Senior Discount	\$	Household/month
2.0	Multi-Family Solid Waste Collection & Disposal w/cart	\$	Household/month
	Price with Senior Discount	\$	Household/month
3.0	Recycling Service (Carts or Collection Bins)	\$	Household/month
	Price with Senior Discount	\$	Household/month
4.0	Landscape Waste Collection (Price of sticker per bag or bundle)	\$	
5.0	White Goods Collection	\$	Per Item
6.0	Bulk Items Collection (first item free)	\$	Per item
		YEAR 7	
1.0	Single-Family Solid Waste Collection & Disposal w/ cart	\$	Household/month
	Price with Senior Discount	\$	Household/month
2.0	Multi-Family Solid Waste Collection & Disposal w/cart	\$	Household/month
	Price with Senior Discount	\$	Household/month
3.0	Recycling Service (Carts or Collection Bins)	\$	Household/month
	Price with Senior Discount	\$	Household/month
4.0	Landscape Waste Collection (Price of sticker per bag or bundle)	\$	
5.0	White Goods Collection	\$	Per Item
6.0	Bulk Items Collection (first item free)	\$	Per item

## **SECTION F: SAMPLE CONTRACT**

The selected Hauler shall enter into a contract with the Township as provided in the Sample Contract attached hereto. Respondents shall submit any proposed modifications to the Sample Contract at the time the Respondent submits its proposal to the Township. Failure to submit proposed modifications to the Sample Contract at the time the proposal is submitted shall be deemed acceptance by the Respondent of the Sample Contract's terms and conditions.

Agreement  
for  
Solid Waste Collection and Recycling Services  
Between  
Maine Township  
and



Effective October     , 2026

## TABLE OF CONTENTS

Preamble	4
<b>I. DEFINITIONS</b>	<b>4</b>
1.1 Definitions	4
<b>II. SCOPE OF SERVICES</b>	<b>6</b>
2.1 Services Provided to Township	
2.2 Billing and Revenue Collection	
2.3 Rebate	
2.4 Modification of Required Services	
<b>III. TERM OF AGREEMENT</b>	<b>7</b>
3.1 Term of Agreement	
<b>IV. WASTE COLLECTION AND DISPOSAL</b>	<b>7</b>
4.1 Description of Waste to be Collected	
4.2 Schedule and Location of Collection	
4.3 Disposal of Waste	
4.4 General Operating Requirements	
4.5 Township and Contractor Representatives	
<b>V. REVENUE COLLECTION PROCEDURES</b>	<b>13</b>
5.1 Billing, Payments, Residential Participation	
<b>VI. TITLE TO WASTE</b>	<b>13</b>
6.1 Title to Waste	
<b>VII. BREACH, EVENTS OF DEFAULT AND REMEDIES</b>	<b>14</b>
7.1 Breach by Contractor	
7.2 Events of Default and Remedies of Township	
<b>VIII. INSURANCE AND INDEMNIFICATION</b>	<b>16</b>
8.1 Insurance	
8.2 Indemnification	
<b>IX. MISCELLANEOUS</b>	<b>16</b>
9.1 Non-Assignability	
9.2 Equal Employment Opportunity	
9.3 Performance Bond	
9.4 Equipment used by Contractor	
9.5 No Alcohol or Drugs	
9.6 Compliance with Laws	

- 9.7 Dispute Resolution
- 9.8 Further Assurances
- 9.9 Relationship and Third Parties
- 9.10 Notices
- 9.11 Waiver
- 9.12 Entire Agreement, Modification
- 9.13 Construction
- 9.14 Counterparts
- 9.15 Prevailing Wage
- 9.16 Document Requests
- 9.17 Certifications
- 9.18 Severability
- 9.19 Law to Govern and Venue

**X. EXHIBITS 25**

- A Township Map
- B Notice of Service Modification
- C Contractors Cost Proposal
- D Insurance Provisions
- E Contractor Proposal

# SOLID WASTE COLLECTION AND RECYCLING SERVICES AGREEMENT BETWEEN MAINE TOWNSHIP AND [REDACTED].

This Solid Waste Collection and Recycling Services Agreement (the "Agreement") is made and entered into as of the [REDACTED] day of **October** in the year 2026 by and between Proposer [REDACTED] (the "Contractor") and **Maine Township**, a body politic and corporate of the State of Illinois (the "Township"). The Contractor and the Township are also hereinafter sometimes jointly referred to as the "Parties" or individually, as a "Party."

## PREAMBLE

**WHEREAS**, Section 210-5 of the Illinois Township Code, 60 ILCS 1/210-15, authorizes townships to enter into contracts for waste hauling and collection services, the Township wishes to enter into an Agreement for the waste hauling and collection Services specified herein; and

**WHEREAS**, the Township has determined to provide waste collection, transportation, and disposal Services for its residents; and

**WHEREAS**, the Township has determined that this Agreement is in the best interests of the Township and its residents to grant the Contractor exclusive rights to collect, transport, recycle and dispose of solid waste, generated from residences located within Township, and Township facilities, pursuant to the terms and conditions of this Agreement; and

**WHEREAS**, the Contractor, pursuant to the terms of this Agreement and on behalf of the Township, is willing to collect and transport all solid waste to a licensed solid waste disposal facility permitted to accept solid waste and collect, transport, recycle and dispose of other waste pursuant to the terms and conditions of this Agreement.

**NOW, THEREFORE**, in consideration of the mutual promises, covenants, and conditions herein contained, the Parties agree as follows:

## I. DEFINITIONS

**1.1 Definitions.** As used in this Agreement, each of the following terms shall have the meaning set forth below:

"**Act**" means the Environmental Protection Act, 415 ILCS §5/1, et. Seq., as amended from time to time and applicable rules and regulations promulgated thereunder.

"**Agreement**" means this Agreement, dated October [REDACTED], 2026 by and between the Township and the Contractor, and as amended from time to time by mutually agreement of the parties.

**"Authorized Representative"** means Supervisor of Township or Township authorized representative to handle day-to-day activities with Contractor. The board shall notify the Contractor who this contact is.

**"breach"** means one of the items described in §§7.1 or 7.2.

**"bulk item"** means items including, but not limited to, beds, box springs, mattresses, sofas, furniture, furnishings, fixtures. Bulk item shall not include hazardous waste or White Goods.

**"cart"** means a two-wheel receptacle with a lid, offered in three sizes for solid waste and recycling and one size for subscription yard waste. Solid waste, recycling, and subscription yard waste carts shall be readily and easily distinguishable from each other. The recycling cart shall have a recycling sticker or permanent stamp on the cart lid showing what materials may be placed in the cart. Such sticker or stamp shall be approved by the Township prior to cart distribution to residential households. The Contractor shall procure, deliver, and maintain carts for the collection of solid waste, recycling, and subscription yard waste and shall provide for the timely exchange of such carts as required to keep and maintain all carts in a good and workmanlike appearance and condition. Damaged or broken carts shall be replaced by Contractor at its sole cost.

**"change in law"** means: (i) the enactment, adoption, promulgation or modification of any federal, state or local law, ordinance, code, rule or regulation; or (ii) the order or judgment of any federal, state or local court, administrative agency or other governmental body; provided that such event changes the costs or ability of the Contractor to perform its Services under this Agreement.

**"construction waste"** means construction or demolition debris as defined in the Illinois Environmental Protection Act, 415 ILCS 5/3.160.

**"Contractor"** means Flood Brothers Disposal Co.

**"event of default"** has the meaning specified in §§7.1 and 7.2.

**"excluded waste"** means (i) hazardous waste, materials, or substances, as such terms are defined under any applicable federal, state, or local laws or regulations; and (ii) waste that is prohibited from being received, managed or disposed of at a transfer, storage or disposal facility used hereunder by federal, state or local law, regulation, ordinance, permit, or other legal requirement.

**"identified Agreement locations"** means all residential household locations in the unincorporated area of Maine Township and all Township owned or operated property or facility locations that receive weekly solid waste disposal and recycling Services from the Contractor.

**"other waste"** means household garbage, household recycling, yard waste, bulk items, white goods, household construction waste and any other materials designated by the Township for collection, except "other waste" does not include any excluded waste.

"**residential household**" means all single-family buildings and multi-family buildings (defined as townhomes/row houses of eight units or less) in the unincorporated area of Maine Township. The term "residential household" expressly excludes condominiums and apartment buildings.

"**recyclable materials**" means the list of recyclables set forth in Exhibit E.

"**Services**" means the specified waste hauling, collection, recycling and disposal Services to be provided by the Contractor, at the direction and on behalf of the Township, pursuant to §2.1.

"**State**" means the State of Illinois.

"**solid waste**" means generally, municipal waste, as defined in the Act.

"**Subcontractor**" means a person or entity that has a direct contract with the Contractor to perform a portion of the Services. (The term "Subcontractor" is referred to throughout this Agreement as if singular in number and means a Subcontractor or an authorized representative of the Subcontractor. The term "Subcontractor" does not include a separate contractor or Subcontractors of a separate contractor.)

"**The Township**" means Maine Township. The geographic boundaries of the Township follow the geographic boundaries as reflected in Exhibit A.

"**white goods**" means all discarded domestic and commercial large appliances, as defined in the Illinois Environmental Protection Act, 415 ILCS 5/22.28.

"**yard waste**" means a bag or bundle of yard or landscape waste where each bag does not exceed thirty five (35) gallons in volume or fifty (50) pounds in weight or where each bundle does not exceed four feet in length by two feet in diameter in volume or fifty (50) pounds in weight. Yard waste shall include: landscape waste as defined at 415 ILCS 5/3.270, garden trash as defined at 70 ILCS 105/3.03, landscape waste as defined at 70 ILCS 3105/3.04, and Christmas trees.

**Where any other term is utilized herein and is not defined herein, but such term is defined within the Illinois Environmental Protection Act, 415 ILCS 1-1, et. seq., (the "Act") such definition from the Act shall take precedence.**

## **II. SCOPE OF SERVICES**

**2.1 Service Provided to Township.** The Township grants Contractor the right to be the exclusive service provider of the Services. The Contractor shall provide the following Services at all Agreement locations:

(a) collection and disposal of solid waste, recyclables and landscape waste curbside every Monday, Thursday and Friday from identified Agreement locations.

(b) collection and disposal of solid waste, recyclables and landscape waste from single-family buildings and eligible multi-family buildings ,every Monday, Thursday and Friday either curbside where such units are suited for curbside collection or in other areas where feasible, such as an alley.

(c) collection, transportation, recycling and disposal of other waste, as provided in this agreement, and

**2.2 Billing and Revenue Collection.** The Contractor shall directly bill each responsible residential household receiving Services on a quarterly basis, in accordance with Article V of this Agreement. The Contractor will also be solely responsible for collecting all fees billed directly from responsible residential households.

**2.3 Rebate.** The Township will receive a rebate on a quarterly basis based on the previous quarter's collected revenue for curbside and dumpster refuse and recycling collection. This rebate will be mailed directly to the Township.

**2.4 Modification of Required Services.** The Township reserves the right to modify or adjust the scope of Services provided under this Agreement, but only if the Township obtains Contractor's prior written consent to modify or adjust the scope of the Services and provides one hundred and eighty days (unless a shorter period of time is mutually agreed by the Contractor and the Township) prior written notice ("Notice of Service Modification", the form of which is attached hereto as Exhibit B) to the Contractor:

(a) to accommodate the Township's decision to implement an alternative form or type of service to be provided by the Contractor,

(b) any other change in Service as mutually agreed to by the Township and the Contractor. The Township and the Contractor agree to negotiate in good faith to make an equitable adjustment to the Contractor's compensation under this Agreement resulting from any such modification or adjustment in the Services provided under this Agreement.

### III. TERM OF AGREEMENT

#### 3.1 Term of Agreement.

The term of this Agreement shall commence on **October** [REDACTED], **2026** and shall expire on [REDACTED] (**Month**) [REDACTED] (**Day**), [REDACTED] (**Year**), unless terminated at an earlier date pursuant to the terms of this Agreement.

### IV. WASTE COLLECTION AND DISPOSAL

#### 4.1 Description of Waste to be Collected.

**(a) Solid Waste.** Materials to be collected and disposed by the Contractor in accordance with the schedule prepared in accordance with §4.2.

**(b) Other Waste.** Materials to be collected by the Contractor, in accordance with the schedule prepared in accordance with §4.2, and disposed, as provided in §4.3, shall include the following:

- (i) bulk materials
- (ii) yard waste
- (iii) recyclable materials
- (iv) white goods
- (v) household construction materials

#### **4.2 Schedule and Location of Collection.**

**(a) Service Hours.** The Contractor, under all service level options, shall provide curbside solid waste Services between the hours of 6:00 AM and 6:00 PM on the established day of collection at all identified Agreement locations. The Contractor shall furnish sufficient numbers of vehicles and personnel to accomplish the Services within this period.

Residents shall be responsible for placing waste carts, containers, bags, bundles, etc. at the curb in front of their residence such that all waste items are made accessible to standard garbage collection and recycling trucks. Refuse will not be collected if stored inside a garage, building or behind a locked gate.

**(b) Collection Days.** The Contractor shall normally conduct collections on Monday, Thursday and Friday, notwithstanding collection delays resulting from Contractor's established holiday schedule, inclement weather, or force majeure.

**(c) Carts.** The Contractor is responsible for purchasing, delivering and maintaining carts over the term of this Agreement at no additional cost to residents or the Township. The Contractor will provide each household with a 95-gallon refuse cart.

**(d) Damaged or Missing Carts.** The Contractor shall purchase, distribute, and maintain or replace damaged or missing carts at all identified Agreement locations at no additional cost to residents or the Township. All Contractor provided carts provided to identified Agreement locations shall remain the property of the Contractor.

#### **4.3 Disposal of Waste.**

The Township shall not direct or require that collected solid waste or other waste be disposed of at any specific facility. The Contractor shall at all times use disposal methods that are in compliance with all Federal, State, County, and local laws, ordinances, and regulations.

**(a) Solid Waste.** The Contractor shall collect and dispose at a permitted solid waste disposal facility all solid waste collected pursuant to this Agreement. The Contractor shall maintain records of proper disposal.

**(b) Recycling Services.** The Contractor will provide each single-family household with a 65-gallon recycle cart. Additional carts are available for interested residents at a rental price of \_\_\_\_\_. All equipment will be owned and maintained by the Contractor. The Contractor will provide preparation requirements for households participating in the recycling program including, rinsing, removing labels, flattening, removing

caps and lids. The Contractor will collect recyclables from the backdoor or alley. There is no limit to the number of recycling bins or to the quantity of recyclables that a household may place at the curb for collection. Residents have the right to set out recycling bins which are clearly marked for recycling collection and do not exceed 35 gallons or 50 pounds.

**(c) Landscape Waste.** The Contractor shall provide once per week unlimited collection of Landscape Waste.

**Landscape Waste Sticker Program.** Residents may place landscape waste bags or bundles at the curb each landscape waste collection day and must apply a prepaid landscape waste sticker. Christmas trees without landscape waste stickers will be collected in January at no charge.

**Landscape Waste Bag/Bundle Subscription.** Residents may place up to six (6) landscape waste bags, containers, or bundles at the curb each landscape waste collection day, without a prepaid waste sticker. The cost will be \$ [redacted] per season.

**Landscape Waste/Food Scrap 95-Gallon Cart Subscription.** Residents are permitted to place landscape waste, along with clean food scraps, in the landscape waste cart for composting. No landscape waste sticker is required. The cost will be \$ [redacted] per season.

All above-described landscape waste disposal collections will occur once per week, from April 1<sup>st</sup> through December 15<sup>th</sup>.

All yard waste shall be placed in a plastic or metal container with a tight cover, or a biodegradable Kraft bag, of a size no larger than 35 gallons and not exceeding 50 pounds. The Contractor will make 65 and 95-gallon carts available for monthly rental by interested residents.

There is no limit on the number of containers placed out for collection by a given household as long as proper yard waste sticker is affixed. The Contractor will accept and collect all bundles of brush or limbs, provided the bundles do not exceed a weight of fifty (50) pounds per bundle, are not more than four (4) feet long, are not more than two (2) feet in diameter, do not contain limbs greater than three (3) inches in diameter and are tied with a material that is accepted at the compost site used by the Contractor.

**(d) White Goods Collection.** The Contractor shall collect White Goods as defined in Section 22.28 of the Illinois Environmental Protection Act on the same day as solid waste is collected from Township residents for the price of \$ [redacted] per item. White Goods items include, but are not limited to appliances, such as refrigerators, dish washers, water heaters, washers, dryers. Residents must call the Contractor 24 hours prior to collection of White Goods to schedule their collection by the Contractor.

**(e) Bulk Items Collection.** The Contractor shall collect one household/bulk item per week free of charge. Additional bulk items over 75 pounds will be charged a fee of \$ [redacted]. Bulk items weighing over 75 pounds must be affixed with two refuse stickers per item. Bulk items are to be placed by the customer at the curb.

**(f) Special Collection Items.** The Contractor will offer a special curbside collection for services that consist of large quantities of refuse including, but not limited to, household construction and demolition debris and move-in or move-out clean up rubbish. These services will require the residents to contact the Contractor prior to collection to make arrangements. Any special collection required to be called in due to weight or quantities will be collected and billed at a minimum of two (2) cubic yards.

**(g) Household Hazardous Waste.** The Contractor will inform residents about how to notify the Contractor when a possible hazardous waste material may need disposal. The Contractor will work with residents to find the best solution for disposal, along with the proposal provided with the assistance Cook County Recycling programs.

**(h) Electronics Collection.** The Contractor will collect electronic waste each week at the individual resident's request.

#### **4.4 General Operating Requirements.**

**(a) Contractor Service with Care.** The Contractor shall undertake to perform all Services rendered hereunder in a clean, orderly, efficient, and workmanlike manner, without supervision by the Township, and to use care and diligence in the performance of all specified Services and to provide neat, orderly, uniformed and courteous employees and personnel on its crews all in accordance with customary industry practices.

**(b) Laws, Rules, Regulations, Permits.** The Contractor shall provide the Services in compliance with all applicable governmental laws, rules, regulations and permits. Except as specifically identified in this Agreement, the Contractor shall pay, when due, all costs and expenses incurred with respect to the Services to be provided pursuant to this Agreement.

**(c) Safety Procedures.** The Contractor shall, in a manner consistent with applicable law, insurance requirements, and recognized safety practice, establish and maintain appropriate safety procedures for the Services provided.

**(d) Precautions.** The Contractor shall take all reasonable precautions for the safety of and shall provide reasonable protection to prevent damage, injury or loss to employees performing the Services and other persons who may be affected thereby. The Contractor shall further take all reasonable precautions to protect public and private property, and report any damaged caused to the Township.

**(e) Public or Private Property Damages.** The Contractor shall be responsible for damages on or to public or private property resulting from careless or negligent operation of vehicles, handling of receptacles, or the operation of overweight or oversize vehicles.

All property which suffers damage (reasonable wear-and-tear excepted) caused by the Contractor, including, but not limited to waste receptacles, sod, mailboxes or recycling bins, shall be repaired or replaced by the Contractor as soon as possible to its original condition at the time of the damage, and at no extra charge to the property owner.

**(f) Vehicles.** Vehicles shall display the name of the Contractor, a local phone number, and a vehicle identification number; all of which are clearly visible on both sides of each vehicle. Vehicles shall be maintained in good working order, fully enclosed, leak-proof, and operated in such a manner that refuse, recyclables, or yard waste shall not leak, spill, or blow off a vehicle as the result of the vehicle operator's failure to properly monitor the load or to close openings. The Contractor shall be responsible for the prompt collection and clean-up of any litter resulting from the operation of its vehicles to collect or transport waste within the Township.

**(g) Contractor Personnel.** The Contractor shall employ an adequate number of qualified personnel, all of whom shall be licensed as required by law, to provide the Services specified under this Agreement.

**(h) Taxes.** The Contractor shall pay all sales, use, property, income and other taxes and fees that are lawfully assessed against the Contractor in connection with the Contractor's facilities and the Services. By law, the Township is exempt from paying Federal Excise Tax, State and Local Retailers' Occupation Tax, State and Local Service Occupation Tax, Use Tax and Service Use Tax. The Township's sales tax-exemption number shall be furnished upon request of the Contractor.

**(i) Licenses, Permits, Certifications.** The Contractor shall secure, at its own expense, all necessary licenses, permits, and certificates of authority required to provide the Services, and shall comply with all requirements of such licenses, permits, and certificates of authority to operate. The Contractor shall keep and maintain all such licenses, permits and certificates of authority in full force and effect throughout the term of this Agreement.

**(j) Container Location and Spilled Materials.** The Contractor shall return all containers at each stop to the location at which they were collected. Containers are to be handled with reasonable care to avoid damage. Any contents spilled by the driver for whatever reason are to be cleaned up immediately. Drivers shall make every reasonable effort to cleanup blowing waste or recycling materials originating from the Contractor's trucks immediately. The Contractor is not responsible for cleaning up blowing debris from containers or identified Agreement locations where the waste or recycling was improperly packaged or became loose prior to arrival. Containers that are blown over by the wind are not the responsibility of the Contractor however, Contractor will make reasonable attempt to stand up blown over containers when possible.

**(k) Missed Pick-Ups.** The Contractor shall promptly investigate and attempt to resolve all complaints made known to Contractor of missed pick-ups and shall arrange for collection of missed pick-ups found to be valid within twenty-four (24) hours after a complaint or notification is received. This Agreement shall require the Contractor to prepare and provide a report to the Township concerning customer usage and customer service, which shall include complaints received by the Contractor and the resolution of said complaints.

**(l) Improperly Prepared Materials.** The Contractor will provide notices ("sorry tag") to be left at the residential household which clearly explains the reason(s) Services (solid waste, yard waste, or recycling collection) were not provided, and what actions, if any, to be taken in the future to ensure collection of materials. Such notices are to be designed and printed by the Contractor at its sole expense.

The form of “sorry tags” and any other related written information to be left at a residential household shall be subject to approval by the Township prior to implementation which approval shall not be unreasonably delayed, denied or withheld.

**(m) Contractor Obligations.** In the event of valid complaints for other incidents, including, but not limited to, breakage of glass during collection of recyclables; items of solid waste, recyclables, or yard waste dropped during collection; and the like are not at the time cleaned up by the collection crew, the Contractor shall promptly arrange for clean-up after a complaint or notification is received.

Contractor shall be prohibited from selectively removing items from carts for collection and shall either accept the entire contents or reject the entire contents of a cart. Contractor shall not be obligated to inspect the contents of a cart for excluded waste or any other unacceptable materials of a type and kind that Contractor determines, in its sole reasonable judgment, that any of the foregoing would be rejected for disposal at the disposal facility.

**(n) Natural Disaster, Force Majeure.** The Township shall be allowed to use alternative contractor(s), at its discretion, in emergency situations. In the event of a severe storm, tornadoes, flood, natural disaster, or any other act of God, the Contractor shall, upon request of the Township, provide special/extra services, including, but not limited to, roll-off containers at locations as directed by the Township, subject to availability of Contractor’s resources. The Contractor and Township shall mutually agree upon rates for said services.

Neither the Contractor nor the Township shall be liable for the inability to perform normal weekly solid waste collection duties nor for any resulting damage or loss, if such inability is caused by a catastrophe, terrorism, riot, war, strike or other work stoppage, fire, accident, Act of God including inclement weather, or similar contingency which is beyond the reasonable control of the Contractor or the Township. Changes in recycling markets or market prices are specifically excluded from the above force majeure contingencies contemplated in this section. If the Contractor or Township claims a delay due to an event of force majeure, it shall give the other party written notice of such event within three (3) calendar days of its occurrence.

**(o) Fees.** The Contractor shall not impose or assess upon any residential household: any fee not previously disclosed to the Township in the Contractor’s cost proposal; impose or assess any fuel surcharges, administrative fees, environmental fees, recycling contamination fee, or similar fees; or charge any amounts in excess of the charges derived solely from the rates set forth in Exhibit C.

#### **4.5 Township and Contractor Representatives.**

The Township shall provide the Contractor with the name of its authorized representative with respect to matters that may arise during the performance of this Agreement, and such person shall have authority to transmit instructions and receive information and confer with the Contractor's Representative. Likewise, the Contractor shall provide the Township with the name of its Representative with respect to matters that may arise during the performance of this Agreement and such person shall have authority to transmit instructions and receive information and confer with the Township's authorized representative. Should any respective representative change, the Township or the Contractor will provide written notice to the other party.

## **V. REVENUE COLLECTION PROCEDURES**

### **5.1 Billing of Accounts, Payment to Contractor, Residential Participation.**

(a) The Contractor shall, on a quarterly basis, bill and collect all rates and charges relating to services under this Agreement in advance of services for each quarter. The Contractor agrees to be solely responsible for the collection of any delinquent accounts and the disposition of all complaints regarding the fees for service. The bill should clearly state and itemize each service provided by the Contractor and the corresponding cost of each service. The Township will receive a 1.0% rebate on a quarterly basis based on the previous quarter's collected revenue for curbside and container refuse and recycling collection. Multi-family locations requesting weekly metal container service will be billed \$            per unit.

(b) The bill shall be payable by each residential household within thirty days of receipt.

(c) The Contractor shall exercise reasonable efforts to inform other solid waste service providers chosen by a residential household of Contractor's exclusive right to provide the Services. The Township shall agree to cooperate and assist the Contractor in the identification of move-ins, move-outs, or other related information that may assist the Contractor in the execution of this subsection to the extent that the Township has access to such information.

(d) The Contractor shall provide the Township with a report listing, upon request, of each identified Agreement location, in a form acceptable to the Township, serviced by the Contractor. The report shall include, but not be limited to, the name, address, phone number, email address, route number, Services provided, and service day of the week of each identified Agreement location.

(e) The Contractor agrees that, based on a pre-paid service billing cycle, any unused full months of service shall be fully refunded when a resident closes an account in good standing. The Contractor agrees to issue a refund to resident within sixty days from receiving notification from the resident.

(f) Contractor shall only terminate service in the event that a residential household fails and refuses to pay all amounts due to Contractor after Contractor has provided the residential household, over a period of not less than ninety days, with both a past due notice and a final notice stating the full amount due and payable to the Contractor or where a residential household repeatedly places excluded waste or other materials not eligible for collection in their cart after having received no less than three written notices from the Contractor not to do so.

## **VI. TITLE TO WASTE**

**6.1 Title to Waste.** The Contractor shall take title of the solid waste and other acceptable waste once it has been collected by the Contractor. Title to and liability for excluded waste shall remain with the residence owner or generator, as the case may be.

## **VII. BREACH, EVENTS OF DEFAULT AND REMEDIES**

**7.1 Breach by Contractor.** Each of the following shall constitute a breach on the part of the Contractor:

(a) failure of the Contractor to pay, within thirty days after written notice from the Township of such nonpayment, amounts which are undisputed or which are due to the Township under this Agreement. Contractor shall give Township prompt written notice of any disputed amount and shall timely pay the undisputed portion of any amount invoiced by Township,

(b) failure of the Contractor to perform timely any material obligation under this Agreement except that such failure shall constitute a breach only if such failure remains uncured for five business days after written notice to the Contractor from the Township (the "cure period") of such failure (unless such breach results in the generation of an immediate hazard to public safety or welfare in which case the Township may require a more expedient cure which is reasonable under the circumstances). If any alleged breach is of such type and kind that it cannot be reasonably cured within the cure period, Contractor shall have a reasonable amount of time in which to effect a cure,

(c) the Contractor's being or becoming insolvent or bankrupt or ceasing to pay its debts as they mature or making an arrangement with or for the benefit of its creditors or consenting to or acquiescing in the appointment of a receiver, trustee, or liquidator for a substantial part of its property,

(d) a bankruptcy, winding up, reorganization, insolvency, arrangement, or similar proceeding being threatened or instituted by the Contractor under the laws of any jurisdiction,

(e) a bankruptcy, winding up, reorganization, insolvency, arrangement, or similar proceeding being instituted against the Contractor under the laws of any jurisdiction, which proceeding has not been dismissed within one hundred twenty days,

(f) any action or answer by the Contractor approving of, consenting to, or acquiescing in any such proceeding, or

(g) the levy of any distress, execution, or attachment upon the property of the Contractor which shall, or which reasonably might be expected to, substantially interfere with its performance under this Agreement.

(h) the assignment or attempt to assign this Agreement to any other party, in bankruptcy or otherwise. This Agreement shall not be an assignable asset of the Contractor and shall not be pledged as collateral, except with the Townships written consent, which consent may be withheld at the sole and absolute discretion of the Township.

**7.2 Events of Default and Remedies of Township.** This §7.2 shall survive the termination of this Agreement. If a breach occurs under §7.1, the Township may exercise any one or more of the following remedies:

(a) The Township may declare an event of default upon a material, uncured breach of a Contractor obligation and may then terminate this Agreement thirty days after such immediately, upon written notice to the Contractor. Upon such termination the Contractor shall cease providing Services under this Agreement. In such event, the Contractor shall immediately refund to all residential households receiving Services under this Agreement the full amount, prorated to the date of termination, any amounts that were prepaid for Services which have not yet been rendered.

(b) The Township may seek and recover from the Contractor any unpaid amounts plus legal fees due the Township, all its substantiated costs for the failure of the Contractor to perform any obligation under this Agreement and all damages, whether based upon Agreement, negligence (including tort), warranty, delay or otherwise, arising out of the performance or non-performance by the Contractor of its obligations under this Agreement, and whether incidental, consequential, indirect or punitive, resulting from the breach.

(c) The Township may:

(i) call upon the sureties to perform their obligations under performance bond or letter of credit,

(ii) Hire replacement contractors to perform the services of Contractor contemplated under this Agreement and charge to Contractor any increased or additional costs incurred by the Township or by any residential household receiving services under this Agreement as costs of cover, or

(iii) in the alternative, after releasing the sureties from their obligations under the performance bond or letter of credit, take over and perform the required services by its own devices, or may enter into a new Agreement for the required services, or any portion thereof, or may use such other methods as shall be required in the opinion of the Township for the performance of the required services.

(d) The Township shall have the power to proceed with any right or remedy granted by federal laws and laws of the State as it may deem best, including any suit, action, or special proceeding in equity or at law for the specific performance of any covenant or agreement contained herein or for the enforcement of any proper legal or equitable remedy as the Township shall deem most effectual to protect the rights aforesaid, insofar as such may be authorized by law.

(e) No remedy by the terms of this Agreement conferred upon or reserved to the Township is intended to be exclusive of any other remedy, but each and every such remedy shall be cumulative and shall be in addition to any other remedy given to the Township. No delay or omission to exercise any right or power accruing upon any event of default shall impair any such right or power or shall be construed to be a waiver of any such event of default or acquiescence therein, and every such right and power may be exercised from time to time and as often as may be deemed expedient. No waiver of any event of default shall extend to or shall affect any subsequent default or event of default or shall impair any rights or remedies consequent thereto.

(f) In the event the Township is obligated to pursue any action against Contractor in order to compel Contractor to perform its obligations hereunder, whether through the issuance of notices or the initiation of litigation, the Township shall be entitled to recover any legal fees or cost incurred by the Township from Contractor, unless such action results in litigation and the Contractor prevails in such litigation.

## **VIII. INSURANCE AND INDEMNIFICATION**

**8.1 Insurance.** The Contractor agrees to carry insurance relating to this Agreement in the amounts and subject to the terms and conditions set forth in Exhibit D. Exhibit D is hereby incorporated into this Agreement.

### **8.2 Indemnification.**

(a) The Contractor shall, at its sole cost and expense, indemnify, defend, keep and hold harmless the Township, its elected and appointed officials, employees, agents, volunteers and consultants (“Indemnitees”) from any and all liability, losses or damages, including attorney's fees and costs of defense, the Indemnitees may suffer as a result of claims, demands, suits, actions or proceedings of any kind or nature, including worker's compensation claims, in any way resulting from or arising out of the operations of the Contractor under the Agreement; and the Contractor shall, at its own expense, appear, defend and pay all fees of attorneys and all costs and other expenses arising therefrom or incurred in connection therewith; and, if any judgments shall be rendered against the Indemnitees in any such action, the Contractor shall, at its own expense, satisfy and discharge same. The Contractor expressly understands and agrees that any performance bond or insurance protection required by the Contractor, or otherwise provided by the Contractor, shall in no way limit the responsibility to indemnify, keep and hold harmless, and defend the Indemnitees as herein provided

(b) The policy limits, availability or unavailability of insurance coverage or the applicability of claims, defenses, or limitations based upon applicable law (including, but not limited to the Illinois Workers’ Compensation Act or similar laws or statutes) shall in no way limit the Contractor’s obligation to indemnify and hold harmless Indemnitees for damage, liabilities, or other costs arising out of or relating to the Contractor’s work or this Agreement.

(c) Nothing in this §8.2 shall apply to suits or actions, which are barred by the applicable statute of limitations.

(d) This §8.2 shall survive the termination of this Agreement.

## **IX. MISCELLANEOUS**

**9.1 Non-Assignability.** This Agreement will not be assignable by the Contractor and the Contractor shall not assign or subcontract this Agreement or the work hereunder, or any part thereof, to any other person, firm, or corporation. The Contractor is required to perform the Services and the Contractor’s other obligations under this Agreement with its own employees.

**9.2 Equal Employment Opportunity.** In the event of the Contractor's noncompliance with the provisions of Section §9.2, the Equal Employment Opportunity Act, the American with Disabilities Act (ADA), the Illinois Human Rights Act, or the Illinois Department of Human Rights Rules and Regulations for Public Contracts, the Contractor may be declared ineligible for future contracts or subcontracts with the State or any of its political subdivisions or municipal corporations, and this Agreement may be canceled or voided, in whole or in part, and such other sanctions or penalties may be imposed or remedies invoked as provided by statute or regulation.

(a) During the term of this Agreement, the Contractor agrees as follows:

(i) That it shall not discriminate against any employee or applicant for employment because of race, color, religion, sex, marital status, national origin or ancestry, age, physical or mental handicap unrelated to ability, or an unfavorable discharge from military service; and further, that it shall examine all job classifications to determine if minority persons or women are underutilized and shall take appropriate affirmative action to rectify any such underutilization.

(ii) That, if it hires additional employees in order to perform this Agreement or any portion hereof, it shall determine the availability (in accordance with the Illinois Department of Human Rights Rules and Regulations) of minorities and women in the area(s) from which it may reasonably recruit and it shall hire for each job classification for which employees are hired in such a way that minorities and women are not underutilized.

(iii) That, in all solicitations or advertisements for employees placed by the Contractor or on the Contractor's behalf, the Contractor shall state that all applicants shall be afforded equal opportunity without discrimination because of race, color, religion, sex, marital status, national origin or ancestry, age, physical or mental handicap unrelated to ability, or an unfavorable discharge from military service.

(iv) That the Contractor shall submit reports as required by the Illinois Department of Human Rights Rules and Regulations, furnish all relevant information as may from time to time be requested by the Illinois Department of Human Rights or the Township, and in all respects comply with the Illinois Human Rights Act and the Illinois Department of Human Rights Rules and Regulations.

(v) That the Contractor shall permit access to all relevant books, records, accounts and work sites by Trustees of the Township and the Illinois Department of Human Rights for purposes of investigation to ascertain compliance with the Illinois Human Rights Act and the Illinois Department of Human Rights Rules and Regulations.

**9.3 Performance Bond.** The Contractor shall furnish a bond payable to the Township in the form of a faithful performance bond for the faithful performance of this Agreement, secured by a surety company acceptable to the Township in an amount equal to one-fifth (1/5) of the estimated amount of the Contractor's total compensation for the first year of the Agreement. The performance bond must be substantially in the form attached as Exhibit D, to be executed by a responsible surety company, licensed

to do business in the State of Illinois. The surety company providing the faithful performance bond shall be a minimum policyholder's rating of A+ and a minimum financial rating of AAA and in all other respects acceptable to the Township. The initial bond shall be posted on or before the date that the Contractor commences providing services to the Township.

**9.4 Equipment to be used by Contractor.** The Contractor agrees to collect all materials described in §4.1 in fully enclosed, leak-proof, modern trucks. The Township shall have the right to inspect all vehicles to ensure vehicles are safe and capable of collecting solid waste and other material.

**9.5 No Alcohol or Drugs.** The Contractor shall prohibit and use its best efforts to enforce the prohibition of any drinking of alcoholic beverages or use of illegal drugs by its drivers and crew members while on duty or within the course of performing their duties under this Agreement.

**9.6 Compliance with Laws.** The Contractor shall comply, and shall cause its agents, employees and Subcontractors to comply, with the requirements of all federal, state and local laws, rules, regulations, licenses, approvals, and permits in all matters pertaining to (a) the Services and (b) all other transactions contemplated by this Agreement.

**9.7 Dispute Resolution.**

(a) In the event any controversy, claim, or dispute between the Contractor and the Township shall arise with respect to the provisions of this Agreement or the transactions contemplated by this Agreement, the Township and the Contractor shall undertake in good faith to resolve the dispute. The Contractor and the Township agree that each have the rights available in law or equity to enforce the terms of this Agreement in the Cook County Circuit Court.

(b) The Contractor and the Township shall continue to perform diligently their respective obligations under this Agreement:

(i) notwithstanding the existence of any dispute, controversy, or claim, and

(ii) during the pendency of any judicial, administrative, or other dispute resolution process which is commenced by one or both parties.

(c) This §9.7 shall survive the termination of this Agreement.

**9.8 Further Assurances.** Each party agrees to execute and deliver any instruments and to perform any acts that may be necessary or reasonably requested in order to carry forth the transactions contemplated by this Agreement so long as such instruments and acts:

(a) are not inconsistent with the provisions of this Agreement, and

(b) do not involve increased costs to provide the Services or the assumption of obligations in addition to the obligations contemplated by this Agreement.

**9.9 Relationship of the Parties, Third Parties.** Nothing in this Agreement shall be deemed to constitute one party as the partner, agent, or legal representative of the other party. Nothing in this Agreement, whether express or implied, is intended to confer any rights or remedies under or by reason of this Agreement on any person other than the parties hereto and their respective legal representatives, successors, and permitted assigns; nor is anything in this Agreement intended to relieve or discharge the obligation or liability of any third parties to any party to this Agreement nor shall any provision give any third parties any right of subrogation or action over or against any party to this Agreement.

**9.10 Notices.** All notices shall be in writing and shall be given by personal delivery, certified or registered mail, email confirmed by the recipient, or prepaid mail carrier to the parties hereto at the respective addresses set forth below. Changes in persons and addresses to which such notices may be directed may be made from time to time by any party by notice in writing to the other party given in accordance with this §10.16.

**Notice to the Township shall be made to:**

**Notice to the Contractor shall be made to:**

Kimberly Jones or Successor  
Township Supervisor  
1700 Ballard Road  
Park Ridge, IL 60068

\_\_\_\_\_  
\_\_\_\_\_  
\_\_\_\_\_  
\_\_\_\_\_

Email: [kjones@mainetown.com](mailto:kjones@mainetown.com)

Email:

**With a copy (via Email) to:**

**With a copy (via Email) to:**

Victoria Rizzo or Successor  
Township Administrator  
1700 Ballard Road  
Park Ridge, IL 60068

\_\_\_\_\_  
\_\_\_\_\_  
\_\_\_\_\_  
\_\_\_\_\_

Email: [vrizzo@mainetown.com](mailto:vrizzo@mainetown.com)

Email: [INSERT EMAIL ADDRESS ]

**9.11 Waiver.**

(a) The waiver of a condition, event of default, or breach under this Agreement must be in a written signed instrument except as otherwise specifically stated in this Agreement. The waiver by either party of an event of default or a breach of any provision of this Agreement by the other party shall not operate or be construed to operate as a waiver of any subsequent event of default or breach. The making or the acceptance of a payment by either party with knowledge of the existence of an event of default or breach shall not operate or be construed to operate as a waiver of the existing or any subsequent event of default or breach.

(b) No approval given by the Township or Contractor under this Agreement shall operate to relieve the other party from any of its responsibilities under this Agreement or be deemed as an approval by the approving party of any deviation contained in any items or document subject to such approval from, or of any failure by the other party to comply with any requirement of this Agreement.

**9.12 Entire Agreement. Modification, Conflicts.** This Agreement sets forth the rights and obligations of the parties to this Agreement. This Agreement:

- (a) constitutes the entire and integrated Agreement between the parties with respect to the transactions contemplated by this Agreement,
- (b) supersedes and replaces all prior negotiations, Agreements, or understandings with respect to the transactions contemplated by this Agreement, and
- (c) may be modified only by written instrument which refers to this Agreement and which is duly executed by both parties.

**9.13 Construction.** Captions and headings in this Agreement are for ease of reference only and do not constitute a part of this Agreement. This Agreement shall not be construed against either the Township or the Contractor. Wherever a date or period of time is specified in this Agreement, such date or period of time shall be of the essence of this Agreement.

**9.14 Counterparts.** This Agreement may be executed in more than one counterpart, each of which shall be deemed to be an original and all of which together shall constitute one and the same instrument.

**9.15 Prevailing Wage.** To the extent applicable, the Contractor shall further comply the requirements of the Prevailing Wage Act in that all laborers, mechanics and other workers performing work under this Agreement which is subject to the Prevailing Wage Act shall be paid not less than the general prevailing rate of hourly wage as provided for in 820 ILCS 130/1 et seq. In such instances, the general prevailing rate of wages in the locality for each craft or type of worker or mechanic needed to execute the contract (and the prevailing rates for legal holiday and overtime work) as ascertained by the Illinois Department of Labor (“Department”) shall be paid by the Contractor and any subcontractor working under him. In such instances the Contractor shall be required to submit prevailing wage records to the Department utilizing the Department’s web portal for such purpose. The Township may, but shall not be required to, demand proof of such submission. Contractor shall also adhere to all applicable prevailing wage scales and rates adopted by the Department. Contractor shall indemnify, defend and hold harmless the Township from any claims arising out of or relating to any actual or alleged non-compliance with the requirements of the Prevailing Wage Act. Prevailing Wage rates for Cook County are posted on the Illinois Department of Labor website.

**9.16 Document Requests.** Contractor acknowledges that the Freedom of Information Act, 5 ILCS 140/1 et seq. (the “Act”) places an obligation on the Township to produce certain records that may be in the possession of Contractor. Contractor shall comply with the record retention and documentation requirements of the Local Records Act 50 ILCS 205/1 et seq. and the Act and shall maintain all records relating to this Agreement in compliance with the Local Records Retention Act and the Act (complying in all respects as if the Contractor was, in fact, the Township). Contractor shall review its records promptly and produce to the Township within two business days of contact from the Township the required documents responsive to a request under the Act. If additional time is necessary to comply with the

request, the Contractor may request the Township to extend the time do so, and the Township will, if time and a basis for extension under the Act permits, consider such extensions. Contractor and Township recognize and acknowledge that this Agreement is a public record as that term is defined in the Act.

#### **9.17 Certifications:**

(a) Executing this Agreement constitutes acknowledgment, acceptance, and certification of the accuracy of the following certifications, and any other certifications required under any applicable law relating to the performance of this Agreement. The Contractor is responsible for identifying all such applicable regulations and certifications, and for compliance with the same.

**(i) Sexual Harassment:** The Contractor certifies that it is in compliance with the Illinois Human Rights Act 775 ILCS 5/1.101, et seq. including establishment and maintenance of sexual harassment policies and program.

**(ii) Tax Delinquency:** The Contractor certifies that it is not delinquent in payment of any taxes to the Illinois Department of Revenue in accordance with 65 ILCS 5/11-42.1 and is not delinquent in the payment of any tax, charge, or obligation.

**(iii) Employment Status:** The Contractor certifies that if any of its personnel are an employee of the State of Illinois, they have permission from their employer to perform the service.

**(iv) Anti-Bribery:** The Contractor certifies it is not barred under 30 Illinois Compiled Statutes 500/50-5(a) - (d) from contracting as a result of a conviction for or admission of bribery or attempted bribery of an officer or employee of the State of Illinois or any other state.

**(v) Loan Default:** If the Contractor is an individual, the Contractor certifies that he/she is not in default for a period of six months or more in an amount of \$600 or more on the repayment of any educational loan guaranteed by the Illinois State Scholarship Commission made by an Illinois institution of higher education or any other loan made from public funds for the purpose of financing higher education (5 ILCS 385/3).

**(vi) Felony Certification:** The Contractor certifies that it is not barred pursuant to 30 ILCS 500/50-10 from conducting business with the State of Illinois or any agency as a result of being convicted of a felony.

**(vii) Barred from Contracting:** The Contractor certifies that it has not been barred from contracting as a result of a conviction for bid-rigging or bid rotating under 720 ILCS 5/33E-3 (Bid Rigging) or 720 ILCS 5/33-4 (Bid Rotating) or a similar law of another state or of the federal government.

**(viii) Drug Free Workplace:** The Contractor certifies that it is in compliance with the Drug Free Workplace Act (30 Illinois Compiled Statutes 580) as of the effective date of this contract. The Drug Free Workplace Act requires, in part, that Contractors, with 25 or more employees certify

and agree to take steps to ensure a drug free workplace by informing employees of the dangers of drug abuse, of the availability of any treatment or assistance program, of prohibited activities and of sanctions that will be imposed for violations; and that individuals with contracts certify that they will not engage in the manufacture, distribution, dispensation, possession, or use of a controlled substance in the performance of the contract. The Contractor further certifies that it maintains a substance-abuse program and provides drug testing in accordance with 820 ILCS 130/11G, Public Act 095-0635.

**(ix) Non-Discrimination, Certification, and Equal Employment Opportunity:** The Contractor agrees to comply with applicable provisions of the Illinois Human Rights Act (775 Illinois Compiled Statutes 5), the U.S. Civil Rights Act, the Americans with Disabilities Act, Section 504 of the U.S. Rehabilitation Act and the rules applicable to each. The equal opportunity clause of Section 750.10 of the Illinois Department of Human Rights Rules is specifically incorporated herein. The Contractor shall comply with Executive Order 11246, entitled Equal Employment Opportunity, as amended by Executive Order 11375, and as supplemented by U.S. Department of Labor regulations (41 C.F.R. Chapter 60). The Contractor agrees to incorporate this clause into all subcontracts under this Contract. The Contractor acknowledges that neither it nor the Township shall discriminate on the basis of any protected classification.

**(x) United States Resident Certification:** (This certification must be included in all contracts involving personal Services by non-resident aliens and foreign entities in accordance with requirements imposed by the Internal Revenue Services for withholding and reporting federal income taxes.) The Contractor certifies that he/she/it is a United States Citizen or Corporation.

**(xi) Tax Payer Certification:** Under penalties of perjury, the Contractor certifies that it possesses a Federal Tax Payer Identification Number and is doing business as a corporation.

**(xii) Authorized in Illinois:** The Contractor certifies that it is authorized to lawfully transact business in the State of Illinois, under all applicable Illinois laws and regulations. The Contractor certifies that it shall comply with the Corporate Accountability for Tax Administration Act, 20 ILCS 715/1, et. seq. Where applicable, the Contractor certifies that it is not barred from bidding by virtue of having been adjudicated to have committed a willing or knowing violation of Section 42 of the Environmental Protection Act within the five years preceding this bid, pursuant to 415 ILCS 5/1, et. seq. The Contractor further certifies that it is in compliance with all applicable requirements of the Business Enterprise for Minorities, Females and Persons with Disabilities Act, 30 ILCS 575/1, et. seq.

**(xiii) General Compliance and Certification:** The Contractor certifies that it has and will comply with all other applicable laws, regulations, ordinances or restrictions applicable to any component of the request for proposal process, agreement, or any Services or materials provided in connection therewith. The Contractor acknowledges that it is responsible for identifying and complying with all applicable laws, ordinances, rules and regulations, and that it shall indemnify and hold harmless the Township from any claim, liability or damages arising out of the failure to identify or comply with any such applicable legal restriction. The Contractor further certifies that

it will pay all taxes applicable to Services under this Agreement and pay all applicable fees under this Agreement.

**9.18 Severability.** In the event that any provision of this Agreement shall, for any reason, be determined to be invalid, illegal, or unenforceable in any respect, the parties shall negotiate in good faith and agree to such amendments, modifications, or supplements to this Agreement or such other appropriate actions as shall, to the maximum extent practical in light of such determinations, implement and give effect to the intentions of the parties as set forth in this Agreement; and the other provisions of this Agreement shall, as and to the extent so amended, modified, supplemented or otherwise affected by such action, remain in full force and effect.

**9.19 Law to Govern and Venue.** This Agreement shall be governed by the laws of the State of Illinois, both as to interpretation and performance, and the venue shall be Cook County, Illinois. Any references to laws in this Agreement shall include such laws as they may be amended or modified from time to time. Every provision of law required by law to be inserted into this Agreement shall be deemed to be inserted herein.

[signature page follows]



**EXHIBIT A – Map of Unincorporated Maine Township**

**EXHIBIT B – Notice of Service Modification**

, 2026

Dear [Contractor]:

Pursuant to §2.4 of the Agreement by and between MAINE TOWNSHIP ["Township"] [redacted] [redacted] [Contractor], dated \_\_\_\_\_, 2026 (the "Service Agreement"), we hereby request that the following modification in the Services currently being provided, effective \_\_\_\_\_, 202\_\_ [Unless mutually agreed by the Contractor and the Township, to be not less than 180 days after the date of this Notice]:

[INSERT THE MODIFICATION OR ADJUSTMENT IN SERVICE REQUESTED BY THE TOWNSHIP]

As required by §2.4 for any service modifications, please provide your written consent to the above-described modifications.

\_\_\_\_\_  
[redacted] [Contractor]

Please contact me at your earliest convenience so that we may promptly commence negotiations to make any equitable adjustments to your compensation required as a result of this modification or adjustment.

Very truly yours,

TOWNSHIP

By:  
Title:

**EXHIBIT C – PRICING FOR CONTRACTOR SERVICES**

**Four (4) Year Option:**

		YEAR 1	
1.0	Single-Family Solid Waste Collection & Disposal w/ cart	\$	Household/month
	Price with Senior Discount	\$	Household/month
2.0	Multi-Family Solid Waste Collection & Disposal w/cart	\$	Household/month
	Price with Senior Discount	\$	Household/month
3.0	Recycling Service (Carts or Collection Bins)	\$	Household/month
	Price with Senior Discount	\$	Household/month
4.0	Landscape Waste Collection (Price of sticker per bag or bundle)	\$	
5.0	White Goods Collection	\$	Per Item
6.0	Bulk Items Collection (first item free)	\$	Per item
		YEAR 2	
1.0	Single-Family Solid Waste Collection & Disposal w/ cart	\$	Household/month
	Price with Senior Discount	\$	Household/month
2.0	Multi-Family Solid Waste Collection & Disposal w/cart	\$	Household/month
	Price with Senior Discount	\$	Household/month
3.0	Recycling Service (Carts or Collection Bins)	\$	Household/month
	Price with Senior Discount	\$	Household/month
4.0	Landscape Waste Collection (Price of sticker per bag or bundle)	\$	
5.0	White Goods Collection	\$	Per Item
6.0	Bulk Items Collection (first item free)	\$	Per item
		YEAR 3	
1.0	Single-Family Solid Waste Collection & Disposal w/ cart	\$	Household/month
	Price with Senior Discount	\$	Household/month
2.0	Multi-Family Solid Waste Collection & Disposal w/cart	\$	Household/month
	Price with Senior Discount	\$	Household/month
3.0	Recycling Service (Carts or Collection Bins)	\$	Household/month
	Price with Senior Discount	\$	Household/month

4.0	Landscape Waste Collection (Price of sticker per bag or bundle)	\$	
5.0	White Goods Collection	\$	Per Item
6.0	Bulk Items Collection (first item free)	\$	Per item
		YEAR 4	
1.0	Single-Family Solid Waste Collection & Disposal w/ cart	\$	Household/month
	Price with Senior Discount	\$	Household/month
2.0	Multi-Family Solid Waste Collection & Disposal w/cart	\$	Household/month
	Price with Senior Discount	\$	Household/month
3.0	Recycling Service (Carts or Collection Bins)	\$	Household/month
	Price with Senior Discount	\$	Household/month
4.0	Landscape Waste Collection (Price of sticker per bag or bundle)	\$	
5.0	White Goods Collection	\$	Per Item
6.0	Bulk Items Collection (first item free)	\$	Per item

**Five (5) Year Option:**

		YEAR 1	
1.0	Single-Family Solid Waste Collection & Disposal w/ cart	\$	Household/month
	Price with Senior Discount	\$	Household/month
2.0	Multi-Family Solid Waste Collection & Disposal w/cart	\$	Household/month
	Price with Senior Discount	\$	Household/month
3.0	Recycling Service (Carts or Collection Bins)	\$	Household/month
	Price with Senior Discount	\$	Household/month
4.0	Landscape Waste Collection (Price of sticker per bag or bundle)	\$	
5.0	White Goods Collection	\$	Per Item
6.0	Bulk Items Collection (first item free)	\$	Per item
		YEAR 2	
1.0	Single-Family Solid Waste Collection & Disposal w/ cart	\$	Household/month
	Price with Senior Discount	\$	Household/month
2.0	Multi-Family Solid Waste Collection & Disposal w/cart	\$	Household/month
	Price with Senior Discount	\$	Household/month
3.0	Recycling Service (Carts or Collection Bins)	\$	Household/month
	Price with Senior Discount	\$	Household/month
4.0	Landscape Waste Collection (Price of sticker per bag or bundle)	\$	
5.0	White Goods Collection	\$	Per Item
6.0	Bulk Items Collection (first item free)	\$	Per item
		YEAR 3	
1.0	Single-Family Solid Waste Collection & Disposal w/ cart	\$	Household/month
	Price with Senior Discount	\$	Household/month
2.0	Multi-Family Solid Waste Collection & Disposal w/cart	\$	Household/month
	Price with Senior Discount	\$	Household/month
3.0	Recycling Service (Carts or Collection Bins)	\$	Household/month
	Price with Senior Discount	\$	Household/month
4.0	Landscape Waste Collection (Price of sticker per bag or bundle)	\$	
5.0	White Goods Collection	\$	Per Item
6.0	Bulk Items Collection (first item free)	\$	Per item

		YEAR 4	
1.0	Single-Family Solid Waste Collection & Disposal w/ cart	\$	Household/month
	Price with Senior Discount	\$	Household/month
2.0	Multi-Family Solid Waste Collection & Disposal w/cart	\$	Household/month
	Price with Senior Discount	\$	Household/month
3.0	Recycling Service (Carts or Collection Bins)	\$	Household/month
	Price with Senior Discount	\$	Household/month
4.0	Landscape Waste Collection (Price of sticker per bag or bundle)	\$	
5.0	White Goods Collection	\$	Per Item
6.0	Bulk Items Collection (first item free)	\$	Per item
		YEAR 5	
1.0	Single-Family Solid Waste Collection & Disposal w/ cart	\$	Household/month
	Price with Senior Discount	\$	Household/month
2.0	Multi-Family Solid Waste Collection & Disposal w/cart	\$	Household/month
	Price with Senior Discount	\$	Household/month
3.0	Recycling Service (Carts or Collection Bins)	\$	Household/month
	Price with Senior Discount	\$	Household/month
4.0	Landscape Waste Collection (Price of sticker per bag or bundle)	\$	
5.0	White Goods Collection	\$	Per Item
6.0	Bulk Items Collection (first item free)	\$	Per item

**Seven (7) Year Option:**

		YEAR 1	
1.0	Single-Family Solid Waste Collection & Disposal w/ cart	\$	Household/month

	Price with Senior Discount	\$	Household/month
2.0	Multi-Family Solid Waste Collection & Disposal w/cart	\$	Household/month
	Price with Senior Discount	\$	Household/month
3.0	Recycling Service (Carts or Collection Bins)	\$	Household/month
	Price with Senior Discount	\$	Household/month
4.0	Landscape Waste Collection (Price of sticker per bag or bundle)	\$	
5.0	White Goods Collection	\$	Per Item
6.0	Bulk Items Collection (first item free)	\$	Per item
		YEAR 2	
1.0	Single-Family Solid Waste Collection & Disposal w/ cart	\$	Household/month
	Price with Senior Discount	\$	Household/month
2.0	Multi-Family Solid Waste Collection & Disposal w/cart	\$	Household/month
	Price with Senior Discount	\$	Household/month
3.0	Recycling Service (Carts or Collection Bins)	\$	Household/month
	Price with Senior Discount	\$	Household/month
4.0	Landscape Waste Collection (Price of sticker per bag or bundle)	\$	
5.0	White Goods Collection	\$	Per Item
6.0	Bulk Items Collection (first item free)	\$	Per item
		YEAR 3	
1.0	Single-Family Solid Waste Collection & Disposal w/ cart	\$	Household/month
	Price with Senior Discount	\$	Household/month
2.0	Multi-Family Solid Waste Collection & Disposal w/cart	\$	Household/month
	Price with Senior Discount	\$	Household/month
3.0	Recycling Service (Carts or Collection Bins)	\$	Household/month
	Price with Senior Discount	\$	Household/month
4.0	Landscape Waste Collection (Price of sticker per bag or bundle)	\$	
5.0	White Goods Collection	\$	Per Item
6.0	Bulk Items Collection (first item free)	\$	Per item
		YEAR 4	
1.0	Single-Family Solid Waste Collection & Disposal w/ cart	\$	Household/month

	Price with Senior Discount	\$	Household/month
2.0	Multi-Family Solid Waste Collection & Disposal w/cart	\$	Household/month
	Price with Senior Discount	\$	Household/month
3.0	Recycling Service (Carts or Collection Bins)	\$	Household/month
	Price with Senior Discount	\$	Household/month
4.0	Landscape Waste Collection (Price of sticker per bag or bundle)	\$	
5.0	White Goods Collection	\$	Per Item
6.0	Bulk Items Collection (first item free)	\$	Per item
		YEAR 5	
1.0	Single-Family Solid Waste Collection & Disposal w/ cart	\$	Household/month
	Price with Senior Discount	\$	Household/month
2.0	Multi-Family Solid Waste Collection & Disposal w/cart	\$	Household/month
	Price with Senior Discount	\$	Household/month
3.0	Recycling Service (Carts or Collection Bins)	\$	Household/month
	Price with Senior Discount	\$	Household/month
4.0	Landscape Waste Collection (Price of sticker per bag or bundle)	\$	
5.0	White Goods Collection	\$	Per Item
6.0	Bulk Items Collection (first item free)	\$	Per item
		YEAR 6	
1.0	Single-Family Solid Waste Collection & Disposal w/ cart	\$	Household/month
	Price with Senior Discount	\$	Household/month
2.0	Multi-Family Solid Waste Collection & Disposal w/cart	\$	Household/month
	Price with Senior Discount	\$	Household/month
3.0	Recycling Service (Carts or Collection Bins)	\$	Household/month
	Price with Senior Discount	\$	Household/month
4.0	Landscape Waste Collection (Price of sticker per bag or bundle)	\$	
5.0	White Goods Collection	\$	Per Item
6.0	Bulk Items Collection (first item free)	\$	Per item
		YEAR 7	
1.0	Single-Family Solid Waste Collection & Disposal w/ cart	\$	Household/month

	Price with Senior Discount	\$	Household/month
2.0	Multi-Family Solid Waste Collection & Disposal w/cart	\$	Household/month
	Price with Senior Discount	\$	Household/month
3.0	Recycling Service (Carts or Collection Bins)	\$	Household/month
	Price with Senior Discount	\$	Household/month
4.0	Landscape Waste Collection (Price of sticker per bag or bundle)	\$	
5.0	White Goods Collection	\$	Per Item
6.0	Bulk Items Collection (first item free)	\$	Per item

## EXHIBIT D – Insurance Provisions

The Contractor must procure and maintain for the duration of the Contract and at its own expense insurance against claims for injuries to persons or damages to property which may arise from or in connection with the performance of the services. All insurance policies shall be written with insurance companies licensed to do business in the State of Illinois and having rating not less than “A” or better, as described in the AM Best Rating Guide. Maine Township, its officers, employees, agents, and volunteers shall be named as additional insureds on all insurance policies required under this Agreement and the Contractor shall provide certificates of insurance to the Township. The Contractor must maintain limits no less than:

### A. WORKERS’ COMPENSATION AND EMPLOYERS LIABILITY INSURANCE

- |                          |                            |
|--------------------------|----------------------------|
| 1. Workers’ Compensation | State Statutory Limits     |
| 2. Employers Liability   | \$1,000,000 (per accident) |

### B. COMMERCIAL GENERAL LIABILITY COVERAGE

- |                         |  |
|-------------------------|--|
| General Aggregate Limit | \$5,000,000 (combined single limit per occurrence for bodily injury, personal injury and property damage). |
|-------------------------|--|

*Note: There shall be no exclusion for explosion, collapse, and underground property damage.*

### C. AUTOMOBILE LIABILITY

- |               |   |
|---------------|---|
| Each Accident | \$5,000,000 (combined single limit per occurrence for bodily injury, personal injury and property damage) |
|---------------|---|
- All owned, non-owned & hired vehicles to be insured.

### D. UMBRELLA LIABILITY COVERAGE

- |                         |             |
|-------------------------|-------------|
| Each Occurrence Limit   | \$1,000,000 |
| General Aggregate Limit | \$1,000,000 |

Maine Township, and all beneficiaries there under and agents thereof shall be named as additional insureds on a primary and non-contributory basis. Contractor shall provide certificates of insurance to the Township.

**Exhibit E – Contractor’s Signed and Submitted Proposal**



4/28/26

---

**TO:** Elected Officials

**FROM:** Victoria Rizzo, Administrator

---

**SUBJECT:** Presentation by Catherine Sbarra from Webb Insurance Group  
Insurance Renewal

---

- Presentation by Catherine Sbarra from Webb Insurance Group
- Discussion and Possible Vote on Insurance Renewal

Catherine Sbarra, V/P Executive Benefits Advisor from Webb Insurance Group, LLC will have a presentation on Maine Township & Highway Department Benefits 7/1/26-6/30/27.

Following Catherine's presentation, the next agenda item is Discussion and Possible Vote on the Insurance Renewal



# MAINE TOWNSHIP



SERVING OUR COMMUNITY SINCE 1850

## Maine Township & Highway Department Employee Benefits 7/1/26 thru 6/30/27

### Partners in Protection

Catherine Sbarra – VP/Executive Benefits Advisor  
[catherine@insurancebywebb.com](mailto:catherine@insurancebywebb.com)

Benefit Service Team

Cara Lovelace - [clovelace@insurancebywebb.com](mailto:clovelace@insurancebywebb.com)

Webb Insurance Group, LLC  
[www.insurancebywebb.com](http://www.insurancebywebb.com)



Prepared for Client

When it comes to the health of your loved ones, it's good to have options.

# Vision

Helping Employers by providing access to quality and cost-effective healthcare programs.

## Mission Statement

Empowering employer groups to maximize their employee benefit investment, while continuing to maintain the highest quality benefit design for their employees through:

Cost Effective Approach

Multiple Options for Employees

Employee Education & Support

# Transforming Healthcare



**Webb Insurance Group benefits division understands that as an employer you need valuable and affordable options to obtain and retain key employees.**

**We are proud to bring you all the options available to your group and evaluate those for you so that you are able to take the most cost-effective approach to bring benefits that will be appreciated by your employees.**

**There are options today that include fully insured, level funded and self funded.**

**Our full market analysis has included all carriers in the marketplace and all funding options to bring and review with you what would best fit your organization for attractive benefits offerings.**

# Changing the Landscape

Our focus is assisting on the development and administration of affordable, cost-effective employee benefits. We work to help transform the landscape of healthcare benefits by serving the needs of employers and their employees.

Through our rigorous evaluation and selection process we bring vendors that are top rated in the industry. We offer custom administrative programs in the areas of medical, dental, prescription drug and vision. Claim Choice also offers members electronic online enrollment and real-time access to data analytics tools to track plan performance.

## BENEFITS BROUGHT TO YOU BY National Group Health Alliance

### ADVOCACY

We provide you with advocacy on employer healthcare issues. We work very diligently to represent your interests. If a member isn't satisfied, neither are we.

### QUALITY

Our rigorous evaluation process when selecting "best in breed" industry leaders means higher-quality benefit programs for your employees.

### AFFORDABLE

Our goal is to obtain offerings that fit the budget to provide the highest value benefit package.

### COMPLIANCE

Since 2014 benefit advisors should also be keeping you well informed of the compliance that applies to your specific employer size and programs you have elected.

### EDUCATION

Details are important and we take pride in the level of service we provide the employer and employees from making their original choices to being there along the way in case there is a claim issue to work with carriers for resolution and confirmation of accuracy of processing according to plan design.

### VALUE

Benefit packages can be very robust without having to increase the budget by offering valuable affordable voluntary options.

### CONSULTATION & REVIEW

We appreciate you giving us the opportunity to consult and educate you on all the options available in this ever-changing industry. Renewals will always include the same full market analysis.

### REPORTING

Some of the most competitively priced options for medical include reporting. We review with you semiannually to keep you informed on how your group is running as well as help us both prepare for renewal.

# Achieving Success For Long Term Solutions To Healthcare



**Webb Advisors only collaborate with the best in class to provide our members with complete packages working with all carriers in the marketplace. We bring effective solutions at the highest service levels in the industry for employers, HR and employees.**

# Employer ABC

Census Information	
Employee	12
Employee & Spouse	7
Employee & Children	5
Family	5
<b>Total</b>	<b>29</b>

General Information	
Current BCBS	\$858,540.84
Renewal BCBS	\$943,533.24
UHC	\$888,478.44
Cigna Not Avail	DTQ
Recommended	

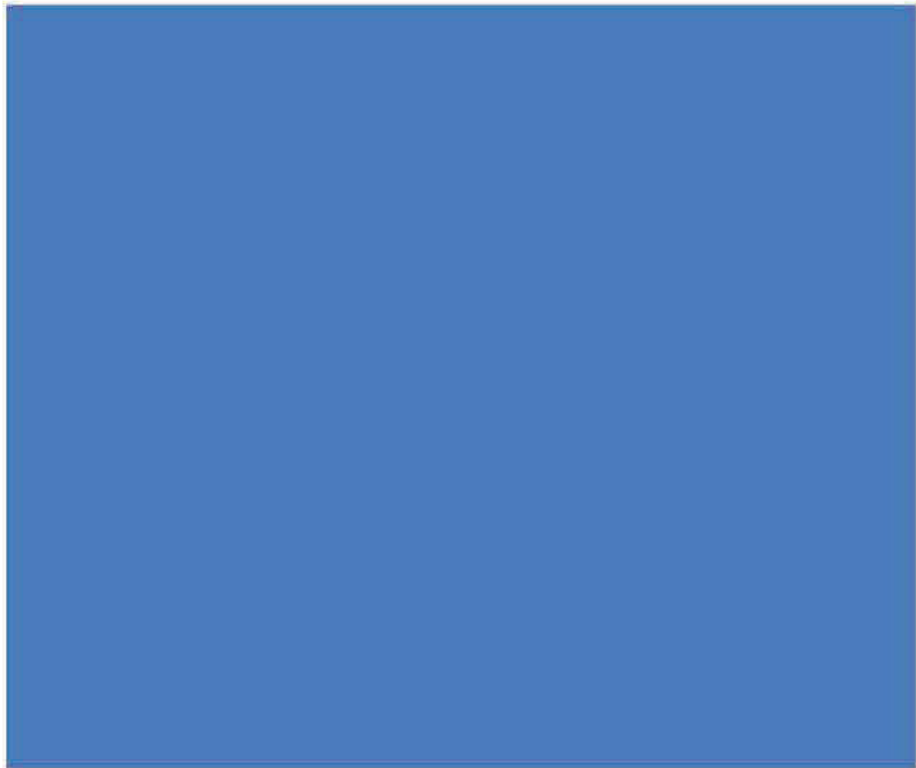

# Proposal Summary

Plan 1	
Plan Name	HMO & PPO
Deductible	\$0 on both plans
Coinsurance	100% on HMO 90% PPO
Out of Pocket Maximum	\$1,500 on HMO \$1,000 on PPO
PCP Copay	\$20 Copay both plans
Specialist Copay	\$40 Copay both plans
Generic RX Copay	\$10 Copay
Brand RX Copay	\$40 Copay hmo \$60 PPO
Brand RX Non-Formulary Copay	\$60 HMO Copay/PPO \$35
Emergency Room Copay	\$150 Copay/Visit
Urgent Care Copay	\$0 copay HMO ded + 10% PPO
Outpatient Surgery	100% HMO ded +10% PPO
Inpatient Hospital	100% HMO ded + 10% PPO

Maine Township & Highway Department  
1700 Ballard Rd  
Park Ridge, IL 60068-1006

April 1, 2026

**Account Number:** 885982  
**Renewal Effective Date:** 07/01/2026

Dear Group Administrator:

We have evaluated your 07/01/2026 group insurance coverage renewal. Your Blue Cross and Blue Shield of Illinois (BCBSIL) current and renewal plans are enclosed.

**Your next steps:**

- Please review your renewal information carefully, including the changes that have been made to your plans for the upcoming year.
- If you want to make changes, please submit your BPS/BPA (Benefit Plan Selection/Benefit Program Application) Form and any other necessary documents 30 days before your effective date.
- If your plans are eligible to stay Grandfathered, important information and instructions about renewing your grandfathered status are enclosed.

Thank you for doing business with us. We appreciate your continued trust. If you have any questions, please reach out to your broker or account representative, our team is ready to help.

Sincerely,

ELAINE J SCHWEISTHAL  
Blue Cross and Blue Shield of Illinois  
(630) 824-6163

**Maine Township & Highway Department**  
**Account # 885982**  
**Renewal Effective: 7/1/2026**  
**Executive Summary**

**Account Detail**

- **Current Medical Plans:** MHHB106 (Blue Advantage HMO), MIBPP2000 (PPO)
  
- **Renewing Medical Plans:** MHHB106 (Blue Advantage HMO), MIBPP2000 (PPO)

**Demographics**

Contract Enrollment:	PPO	HMO	Total
2025	32	2	34
2026	27	2	29

**Rate Development**

**Health Renewal Premium Change Components**

a. Account/Benefit Program Adjustment (incl. Trend):	12.0%
b. Demographic Adjustment:	-0.4%
c. Pricing Adjustment:	1.5%
<b>Total Health Rate Action*:</b>	<b>13.2%</b>

*\*The total health renewal premium change percentage is calculated by multiplying each of the components in the above table. This change percentage is based upon total monthly premium. Each tier's rate change may vary from the total change percentage.*

**Change Components Definitions**

- a. Account/Benefit Program Adjustment (incl. Trend) includes group and benefit plan specific pricing changes due to factors such as medical cost trends, pool adjustments, plan, industry and geographical pricing, etc.
- b. Demographic Adjustment is the pricing change for age, group size and dependent composition differences.
- c. Pricing Adjustment is the pricing change resulting from BCBSIL's analysis of medical conditions, experience and other adjustments.

**Current High Cost Claimants**

Following is the large claim detail identified during the renewal evaluation: \$50,000+ (More than 50 Contracts Enrolled)

Maine Township & Highway Department Account # 885982 Renewal Effective: 7/1/2026 Rate Development				
Renewing Plan Name	MHHB106		MIBPP2000	
	Blue Advantage HMO		PPO	
Network				
Product	Blue Advantage HMO		BluePrint PPO	
	In	Out	In	Out
Deductible (Individual/Family)	\$0 /NA	NA	\$0/\$0	\$0/\$0
Coinsurance	NA	NA	90%	70%
Out of Pocket (Individual/Family)	\$1,500 /\$3,000	NA	\$1,000/\$3,000	\$3,000/\$9,000
Office Visit Copay/ Specialist Copay	\$20 /\$40	NA	\$20/\$40	DC
Inpatient Copay	\$0	NA	NA	\$300/POD
Emergency Room	\$150	\$200	\$150	\$150/POD
In-network Preferred Pharmacy	NA		\$0/\$10/\$50/\$100/\$150/\$250	
In-network Non-Preferred Pharmacy	NA		\$10/\$20/\$70/\$120/\$150/\$250	
<b>BCBSIL Contracts</b>				
Single	2		10	
Single + Spouse	0		7	
Single + Child(ren)	0		5	
Family	0		5	
Medicare Primary Single	0		0	
Medicare Primary Single+1	0		0	
<b>BCBSIL Rates</b>				
	Current	Renewal	Current	Renewal
Single	\$973.32	\$971.59	\$1,447.75	\$1,686.41
Single + Spouse	\$2,147.44	\$2,044.39	\$3,194.14	\$3,548.50
Single + Child(ren)	\$1,615.54	\$1,614.83	\$2,402.99	\$2,802.91
Family	\$2,789.65	\$2,687.64	\$4,149.40	\$4,664.99
<b>Medicare Rates</b>				
Single	\$523.17	\$511.97	\$778.18	\$888.65
Family	\$1,046.33	\$1,023.96	\$1,556.35	\$1,777.30
<b>Monthly Premium at Current Rates</b>	\$1,946.64		\$69,598.43	
<b>Monthly Requested Premium at Renewal Rates</b>	\$1,943.18		\$79,043.10	
<b>Rate Action By Plan</b>	-0.2%		13.6%	
<b>Overall Rate Action</b>	13.2%			

Maine Township & Highway Department  
1700 Ballard Rd  
Park Ridge, IL 60068-1006

April 3, 2026

Revised

**Account Number:** 885982  
**Renewal Effective Date:** 07/01/2026

Dear Group Administrator:

We have evaluated your 07/01/2026 group insurance coverage renewal. Your Blue Cross and Blue Shield of Illinois (BCBSIL) current and renewal plans are enclosed.

**Your next steps:**

- Please review your renewal information carefully, including the changes that have been made to your plans for the upcoming year.
- If you want to make changes, please submit your BPS/BPA (Benefit Plan Selection/Benefit Program Application) Form and any other necessary documents 30 days before your effective date.
- If your plans are eligible to stay Grandfathered, important information and instructions about renewing your grandfathered status are enclosed.

Thank you for doing business with us. We appreciate your continued trust. If you have any questions, please reach out to your broker or account representative, our team is ready to help.

Sincerely,

ELAINE J SCHWEISTHAL  
Blue Cross and Blue Shield of Illinois  
(630) 824-6163

**Maine Township & Highway Department  
Account # 885982  
Renewal Effective: 7/1/2026  
Executive Summary**

**Account Detail**

- **Current Medical Plans:** MHHB106 (Blue Advantage HMO), MIBPP2000 (PPO)
  
- **Renewing Medical Plans:** MHHB106 (Blue Advantage HMO), MIBPP2000 (PPO)

**Demographics**

Contract Enrollment:	PPO	HMO	Total
2025	32	2	34
2026	27	2	29

**Rate Development**

**Health Renewal Premium Change Components**

a. Account/Benefit Program Adjustment (incl. Trend):	12.0%
b. Demographic Adjustment:	-0.4%
c. Pricing Adjustment:	-1.4%
<b>Total Health Rate Action*:</b>	<b>9.9%</b>

*\*The total health renewal premium change percentage is calculated by multiplying each of the components in the above table. This change percentage is based upon total monthly premium. Each tier's rate change may vary from the total change percentage.*

**Change Components Definitions**

- a. Account/Benefit Program Adjustment (incl. Trend) includes group and benefit plan specific pricing changes due to factors such as medical cost trends, pool adjustments, plan, industry and geographical pricing, etc.
- b. Demographic Adjustment is the pricing change for age, group size and dependent composition differences.
- c. Pricing Adjustment is the pricing change resulting from BCBSIL's analysis of medical conditions, experience and other adjustments.

**Current High Cost Claimants**

Following is the large claim detail identified during the renewal evaluation: \$50,000+ (More than 50 Contracts Enrolled)

Maine Township & Highway Department Account # 885982 Renewal Effective: 7/1/2026 Rate Development				
Renewing Plan Name	MHHB106		MIBPP2000	
Network	Blue Advantage HMO		PPO	
Product	Blue Advantage HMO		BluePrint PPO	
	In	Out	In	Out
Deductible (Individual/Family)	\$0 /NA	NA	\$0/\$0	\$0/\$0
Coinsurance	NA	NA	90%	70%
Out of Pocket (Individual/Family)	\$1,500 /\$3,000	NA	\$1,000/\$3,000	\$3,000/\$9,000
Office Visit Copay/ Specialist Copay	\$20 /\$40	NA	\$20/\$40	DC
Inpatient Copay	\$0	NA	NA	\$300/POD
Emergency Room	\$150	\$200	\$150	\$150/POD
In-network Preferred Pharmacy	NA		\$0/\$10/\$50/\$100/\$150/\$250	
In-network Non-Preferred Pharmacy	NA		\$10/\$20/\$70/\$120/\$150/\$250	
<b>BCBSIL Contracts</b>				
Single	2		10	
Single + Spouse	0		7	
Single + Child(ren)	0		5	
Family	0		5	
Medicare Primary Single	0		0	
Medicare Primary Single+1	0		0	
<b>BCBSIL Rates</b>	<b>Current</b>	<b>Renewal</b>	<b>Current</b>	<b>Renewal</b>
Single	\$973.32	\$943.30	\$1,447.75	\$1,637.30
Single + Spouse	\$2,147.44	\$1,984.85	\$3,194.14	\$3,445.16
Single + Child(ren)	\$1,615.54	\$1,567.81	\$2,402.99	\$2,721.28
Family	\$2,789.65	\$2,609.37	\$4,149.40	\$4,529.13
<b>Medicare Rates</b>				
Single	\$523.17	\$497.06	\$778.18	\$862.77
Family	\$1,046.33	\$994.14	\$1,556.35	\$1,725.54
<b>Monthly Premium at Current Rates</b>	\$1,946.64		\$69,598.43	
<b>Monthly Requested Premium at Renewal Rates</b>	\$1,886.60		\$76,741.17	
<b>Rate Action By Plan</b>	-3.1%		10.3%	
<b>Overall Rate Action</b>	9.9%			

**Maine Township**

BlueCross BlueShield of Illinois Renewal **Illustration Only Refer to SBC for Complete Details**  
 July 2026 Renewal

**Yellow worse benefit** No color same benefit

	Blue Cross MHHB106 HMOCurrent/Renewal		Blue Cross MIBPP2000		UHC FIRM EGIU (Nav PCP Led) RX 2VX		UHC EYMM RX 2VX BDSS Compare to PPO BCBS PPO Copay Plan	
	HMO	PPO	PPO		HMO	PPO		
Plan Type	HMO		PPO		HMO		PPO	
Network	Blue Advantage		Blue Print		Navigate		Core Premier	
Benefit Highlights	In-Network		In-Network	Out-of-Network	In Network Only		In-Network	Out-of-Network
Lifetime Maximum	Unlimited		Unlimited		Unlimited		Unlimited	
Deductible								
Individual	\$0		\$0	\$1,000	\$0		\$0	\$5,000
Family	\$0		\$1,500	\$3,000	\$0		\$0	\$10,000
Coinsurance	100%		90%	70%	100%		100%	80%
Maximum Out-of-Pocket								
Individual	\$1,500		\$1,000	\$3,000	\$1,500		\$1,750	\$10,000
Family	\$3,000		\$3,000	\$9,000	\$3,000		\$3,500	\$20,000
Office Visits								
Primary	\$20 copay		\$20 copay	30% after deduct.	\$20 copay		\$20 copay	20% after deduct
Specialist	\$40 copay		\$40 copay	30% after deduct.	\$40 copay		\$40 copay	20% after deduct
Preventative Care	100%		100%	30% after deduct.	100%		100%	20% after deduct
Hospital Services	100%		10% after deduct.	\$300 copay/visit then 30% after deduct.	100%		IP \$500/Visit then 100% after deduct OP \$250/Visit then 100% after deduct	20% after deduct
Emergency Room	\$150 copay/visit		\$150 copay/visit		\$300 copay/visit then 100% covered		\$300 copay/visit	
Urgent Care	100%		10% after deduct.	30% after deduct.	\$50 copay/visit		\$50 copay/visit	20% after deduct
Prescription Drugs	Participating Pharmacies		Participating Pharmacies		Participating Pharmacies		Participating Pharmacies	
Generic	\$10 copay		\$10 or \$20 copay		\$10 copay		\$10 copay	
Preferred Brand	\$40 copay		\$50 or \$70 copay		\$35 copay		\$35 copay	
Non-Preferred Brand	\$60 copays/Specialty Covered		\$100 or \$250 copay / Specialty \$250		\$60 copay		\$60 copay	
Mail Order	3 copays for 3 mo supply 7.1.24		3 copays for 3 mo supply		2.5 copays for 3 mo supply		2.5 copays for 3 mo supply	
Rates	HMO	PPO	HMO		HMO		HMO	
			CURRENT	RATE RELIEF APPLIED	CURRENT	RATE RELIEF APPLIED	UHC FIRM 7/1/26	UHC FIRM 7/1/24
Employee	2	10	\$973.32	\$943.30	\$1,447.75	\$1,637.30	\$1,030.33	\$1,535.70
Employee + Spouse	0	7	\$2,147.44	\$1,984.85	\$3,194.14	\$3,445.16	\$2,167.99	\$3,231.38
Employee + Child(ren)	0	5	\$1,615.54	\$1,567.81	\$2,402.99	\$2,721.28	\$1,712.47	\$2,552.42
Family	0	5	\$2,789.65	\$2,609.37	\$4,149.40	\$4,529.13	\$2,850.12	\$4,248.09
TOTALS	2	27						
Monthly Premium			\$1,946.64	\$1,886.60	\$69,598.43	\$76,741.17	\$2,060.66	\$71,979.21
Annual Premium			\$23,359.68	\$22,639.20	\$835,181.16	\$920,894.04	\$24,727.92	\$863,750.52
Combined HMO & PPO Annual Premium			\$858,540.84		\$943,533.24		\$888,478.44	
Premium Difference From Current			\$84,992.40				\$29,937.60	
Percentage Change From Current			9.90%				3.49%	

This is a coverage and benefit illustration only; refer to the carrier highlight sheets and plan document for specific conditions, coverage and limitations.

Maine Township & Highway Department

DENTAL

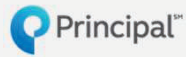

		Current	Renewal			
<b>Benefit Details</b>						
Out-of-Network Type		MAC		MAC	MAC	MAC
Annual Maximum		\$1,800		\$2,050	\$2,050	\$1,800
Individual Deductible		\$50		\$50	\$50	\$50
Family Deductible		\$150		\$150	\$150	\$150
Deductible Waived for Preventive		Yes		Yes	Yes	Yes
<b>Coinsurance</b>						
Preventive Services		100%		100%	100%	100%
Basic Services		80%		80%	80%	80%
Major Services		50%		50%	50%	50%
Ortho Services		Not Covered		Not Covered	Not Covered	Not Covered
<b>Additional Benefit Details</b>						
Endodontics		Major		Major	Major	Major
Periodontics		Major		Major	Major	Major
Oral Surgery		Basic		Basic	Basic	Basic
Implants		Major		Major	Major	Major
Waiting Period		None	R	None	None	None
Maximum Rollover		Included		Not Included	Not Included	Not Included
Oral Exam Frequency		2 per 12 months		2 per 12 months	2 per 12 months	2 per 12 months
Cleaning Frequency		2 per 12 months		2 per 12 months	2 per 12 months	2 per 12 months
Full Mouth X-Ray Frequency		1 per 60 months		1 per 60 months	1 per 36 months	1 per 60 months
<b>Additional Information</b>						
Contribution		Split Contributory		Split Contributory	Split Contributory	Split Contributory
Dependent Age Limits		Up to Age 26		Up to Age 26	Up to Age 26	Up to Age 26
Participation Requirement		Not Mentioned		80%	The greater of 66% or 10 enrolled	65%
<b>Financial</b>						
	Count					
Single	10	\$38.25	\$39.78	\$33.84	\$38.25	\$35.85
Employee + Spouse	9	\$74.41	\$77.39	\$66.43	\$78.60	\$72.72
Employee + Child(ren)	5	\$81.40	\$84.66	\$71.39	\$86.77	\$93.13
Family	6	\$125.60	\$130.62	\$110.94	\$140.99	\$141.21
Rate Guarantee				2 years	1 year, 7% 2nd Year Rate Cap	2 years
<b>Notes / Comments</b>						
Monthly Rates (Enrollment illustrated from Invoice Report)						

COST ANALYSIS

Monthly Premium		\$2,213	\$2,301	\$1,959	\$2,370	\$2,326
Annual Premium		\$26,553	\$27,616	\$23,506	\$28,436	\$27,911
Annual Change vs Current		\$1,062		-\$3,047	\$1,883	\$1,357
% Change from Current		4.00%		-11.48%	7.09%	5.11%

This summary is for illustrative purposes only and is not a contract. RR given from 6.80% increase

Pricing Assumes Package Sale unless otherwise noted.

Please refer to carrier proposal for full details.

Commissions		10%		10%	10%	10%
-------------	--	-----	--	-----	-----	-----

Maine Township & Highway Department

VISION



		Current			Plan 1	Plan 2	
<b>Benefit Details</b>							
Network		VSP	VSP	VSP	VSP	Davis	Spectera
<b>Copays &amp; Allowances</b>							
Exam Copay		\$10	\$10	\$10	\$10	\$10	\$10
Materials Copay		\$25	\$25	\$25	\$25	\$25	\$25
Frame allowance		\$130	\$130	\$130	\$130	\$130	\$130
Contact Allowance		\$130	\$130	\$130	\$130	\$130	\$125
<b>Frequency</b>							
Examination		Once every 12 months	Once every 12 months	Once every 12 months	Once every 12 months	Once every 12 months	once every 12 months
Lenses		Once every 12 months	Once every 12 months	Once every 12 months	Once every 12 months	Once every 12 months	once every 12 months
Frames		Once every 12 months	Once every 12 months	Once every 12 months	Once every 12 months	Once every 12 months	once every 12 months
<b>Additional Information</b>							
Contribution		<b>100% Voluntary</b>	<b>Split Contributory</b>	<b>100% Voluntary</b>	<b>100% Voluntary</b>	<b>100% Voluntary</b>	<b>100% Voluntary</b>
Dependent Age Limits		Up to Age 26	Up to Age 26	Not Mentioned	Up to Age 26	Up to Age 26	Not Mentioned
Participation Requirement		Not Mentioned	42%	The greater of 42% or 4 enrolled	59%	59%	2 enrolled
<b>Financial</b>							
	<b>Count</b>						
Single	7	\$7.42	\$8.82	\$7.30	\$9.92	\$7.63	\$7.10
Employee + Spouse	9	\$11.87	\$17.66	\$12.80	\$18.79	\$14.43	\$13.48
Employee + Child(ren)	4	\$12.12	\$14.95	\$13.99	\$19.14	\$14.71	\$15.83
Family	2	\$19.55	\$24.65	\$22.88	\$30.31	\$23.28	\$22.27
Rate Guarantee		No change until 7/1/27	2 years	2 years	2 years	2 years	2 years
<b>Notes / Comments</b>							
Monthly Rates (Enrollment illustrated from Invoice Report)					Vision is sold with Dental.	Vision is sold with Dental.	*Proposal assumes the vision plan is sold with at least one additional line of coverage

COST ANALYSIS

Monthly Premium	\$246	\$330	\$268	\$376	\$289	\$279
Annual Premium	\$2,956	\$3,957	\$3,216	\$4,509	\$3,464	\$3,347
Annual Change vs Current		\$1,001	\$260	\$1,553	\$508	\$390
% Change from Current		33.87%	8.80%	52.52%	17.18%	13.20%

This summary is for illustrative purposes only and is not a binding quote.

Pricing Assumes Package Sale unless otherwise noted.

## Maine Township & Highway Department

### LIFE AND AD&D



	Current				
<b>Benefit Details</b>					
Class Description	All Eligible Employees	All Eligible Employees	All Eligible Employees	All Eligible Employees	All Eligible Employees
Life & AD&D Benefit	\$25,000	\$25,000	\$25,000	\$25,000	\$25,000
Guaranteed Issue (GI)	\$25,000	\$25,000	\$25,000	\$25,000	\$25,000
Reduction Schedule	None	65% @ 65   50% @ 70	65% @ 65   50% @ 70	65% @ 65   50% @ 70	65% @ 65   40% @ 70   25% @ 75
<b>Additional Benefit Details</b>					
Waiver of Premium	Included	Included	Included	Included	Included
Portability	Not Included	Not Included	Not Included	Included	Not Included
Conversion	Included	Included	Included	Included	Included
<b>Financial</b>					
Employer Contribution Level	<b>100% Employer Paid</b>	<b>100% Employer Paid</b>	<b>100% Employer Paid</b>	<b>100% Employer Paid</b>	<b>100% Employer Paid</b>
Monthly Volume (estimated for comparison purposes only)	\$950,000	\$950,000	\$950,000	\$950,000	\$950,000
Life Rate (per \$1000)	<b>\$0.252</b>	<b>\$0.235</b>	<b>\$0.227</b>	<b>\$0.221</b>	<b>\$0.227</b>
AD&D Rate (per \$1000)	<b>\$0.036</b>	<b>\$0.020</b>	<b>\$0.036</b>	<b>\$0.036</b>	<b>\$0.036</b>
Rate Guarantee	<b>Not Mentioned</b>	<b>2 years</b>	<b>2 years</b>	<b>2 years</b>	<b>3 years</b>
<b>Notes / Comments</b>					
Monthly Volume (Enrollment illustrated for Comparison Purposes)					

### COST ANALYSIS

Monthly Premium	\$274	\$242	\$250	\$244	\$250
Annual Premium	\$3,283	\$2,907	\$2,998	\$2,930	\$2,998
Annual Change vs Current	<b>No change until 7.1.27</b>	<b>-\$376</b>	<b>-\$285</b>	<b>-\$353</b>	<b>-\$285</b>
% Change from Current		<b>-11.46%</b>	<b>-8.68%</b>	<b>-10.76%</b>	<b>-8.68%</b>

*This summary is for illustrative purposes only and is not a binding quote.*

**Pricing Assumes Package Sale unless otherwise noted.**

*Please refer to carrier proposal for full details.*

Commissions	15%	15%	15%	15%	15%
-------------	-----	-----	-----	-----	-----

Maine Township & Highway Department

VOLUNTARY LIFE AND AD&D



	Current				
<b>Employee Benefit Schedule</b>					
Employee Increments	\$10,000	\$10,000	\$10,000	\$10,000	\$10,000
Employee Maximum	\$300,000	\$500,000	\$300,000	\$300,000	\$300,000
Salary Limitation	None	5x	5x	None	5x
<b>Spouse Benefit Schedule</b>					
Spouse Increments	\$5,000	\$5,000	\$5,000	\$5,000	\$5,000
Spouse Maximum	\$100,000	\$100,000	\$100,000	\$100,000	\$100,000
% of Employee Benefit Limit	50%	50%	50%	50%	50%
<b>Child(ren) Benefit Schedule</b>					
Child Increments	Not Mentioned	Not Mentioned	\$2,000	Not Mentioned	Not Mentioned
Child Maximum	\$10,000	\$10,000	\$10,000	\$10,000	\$10,000 or \$20,000
<b>Guaranteed Issue (GI)</b>					
Employee Guarantee Issue	\$100,000	\$100,000	\$100,000	\$100,000	\$50,000
Spouse Guarantee Issue	\$25,000	\$25,000	\$25,000	\$25,000	\$10,000
Child Guarantee Issue	\$10,000	\$10,000	\$10,000	\$10,000	\$20,000
<b>Additional Benefit Details</b>					
Age Reduction Schedule	65% @ 65   50% @ 70	None	65% @ 65   50% @ 70	65% @ 65   50% @ 70	65% @ 65   50% @ 70
Waiver of Premium	Included	Included	Included	Included	Included
Portability	Included	Included	Included	Included	Included
Conversion	Included	Included	Included	Included	Included
Participation Requirement	Not Mentioned	25%	The greater of 20% or 4 enrolled	The greater of 35% or 10 enrolled	The greater of 25% or 10 enrolled
<b>Rate (Per \$1000)</b>					
Under 25	\$0.045	\$0.045	\$0.045	\$0.062	\$0.045
25 - 29	\$0.045	\$0.045	\$0.045	\$0.062	\$0.045
30 - 34	\$0.056	\$0.056	\$0.056	\$0.067	\$0.056
35 - 39	\$0.079	\$0.079	\$0.079	\$0.093	\$0.079
40 - 44	\$0.121	\$0.121	\$0.121	\$0.134	\$0.121
45 - 49	\$0.205	\$0.205	\$0.205	\$0.214	\$0.205
50 - 54	\$0.358	\$0.358	\$0.358	\$0.356	\$0.358
55 - 59	\$0.620	\$0.620	\$0.620	\$0.566	\$0.620
60 - 64	\$0.988	\$0.988	\$0.988	\$0.869	\$0.988
65 - 69	\$1.628	\$1.628	\$1.628	\$1.747	\$1.628
70 - 74	\$2.904	\$2.904	\$2.904	\$3.270	\$2.904
75 - 79	\$2.904	\$2.904	\$2.904	\$3.270	\$2.904
80 - 84	\$2.904	\$2.904	\$2.904	\$3.270	\$2.904
85 - 89	\$2.904	\$2.904	\$2.904	\$3.270	\$2.904
90 - 94	\$2.904	\$2.904	\$2.904	\$3.270	\$2.904
95 - 99	\$2.904	\$2.904	\$2.904	\$3.270	\$2.904
Child(ren)	\$0.200	\$0.240	\$0.200	\$0.200	\$0.200
Employee AD&D	\$0.036	\$0.021	\$0.036	\$0.036	\$0.036
Spouse AD&D	\$0.036	\$0.021	\$0.036	\$0.036	\$0.036
Child(ren) AD&D	Not Offered	\$0.051	\$0.090	\$0.036	Not Offered

# Our Partners



**MAINE TOWNSHIP, COOK COUNTY, ILLINOIS**

**ORDINANCE NO. 2026-2**

**AN ORDINANCE APPROVING A PURCHASE AND SALE AGREEMENT  
FOR THE PURCHASE OF CERTAIN PROPERTY LOCATED AT 9850 MILWAUKEE AVENUE  
FROM CHICAGO TITLE LAND TRUST COMPANY**

**WHEREAS**, Maine Township (the “Township”) is a unit of local government organized and operating under the laws of the State of Illinois; and

**WHEREAS**, Section 1/85-10(c) of the Illinois Township Code, 60 ILCS 1/85-10(c), authorizes the Township to purchase any real estate for public purposes; and

**WHEREAS**, Section 1/85-10(d) of the Illinois Township Code, 60 ILCS 1/85-10(d), authorizes the Township to make all contracts necessary in the exercise of the Township’s powers; and

**WHEREAS**, Chicago Title Land Trust Company (“Chicago Title”), an Illinois land trust corporation, has expressed an interest in selling certain real property located at 9850 Milwaukee Ave, Glenview, Illinois (“Property”); and

**WHEREAS**, on April 14, 2026, at the Township’s Annual Town Meeting of Electors, the Township electors voted to approve a Resolution, a copy of which is attached hereto as Exhibit A, authorizing the purchase of the Property for the Township food pantry and other public purposes; and

**WHEREAS**, the Resolution authorized and directed the Maine Township Board of Trustees to enter into a real estate purchase and sale agreement for the purchase of the Property for a sum not to exceed funds that the Township currently has in the town fund and/or capital reserves and without imposing any new or higher taxes to fund the purchase price; and

**WHEREAS**, pursuant to and in accordance with the authority granted by the electors through the passage of the Resolution, the Maine Township Board of Trustees has negotiated the terms and provisions of a Purchase and Sale Agreement with Chicago Title, for the purchase of the Property (“Agreement,” attached hereto as Exhibit B); and

**WHEREAS**, the Maine Township Board of Trustees, pursuant to the determination and direction of the Township electors, finds and determines that the Agreement is consistent with the Resolution and now desires to approve the Agreement.

**NOW, THEREFORE, BE IT ORDAINED** by the Board of Trustees of Maine Township, Cook County, Illinois as follows:

**Section 1.**        **Recitals.** The recitals and all exhibits attached to this Ordinance are incorporated into this Section 1 as though fully set forth herein.

**Section 2.**        **Approval; Authorization.** The Township Board of Trustees hereby approves the Agreement attached hereto as Exhibit B, subject to Township attorney review and approval. The Township Supervisor and Township Clerk are authorized and directed to execute the Agreement on the Township's behalf, and the Township Supervisor is hereby authorized to take all actions necessary to implement and enforce the Agreement's terms, and to consummate the closing on the conveyance of the Property to the Township.

**Section 3.**        **Superseder.** All previous ordinances, resolutions and parts thereof in conflict with this Ordinance are hereby repealed to the extent and only to the extent they conflict with this Ordinance.

**Section 4.**        **Severability.** If any part, subsection, or clause of this Ordinance shall be deemed invalid, the remaining parts, subsections, and clauses shall not be affected thereby.

**Section 5.**        **Effective Date.** This Ordinance shall be in full force and effect from and after its passage and approval as provided by law.

AYES:

NAYES:

APPROVED this \_\_\_\_ day of April, 2026.

**MAINE TOWNSHIP**

\_\_\_\_\_  
Kimberly Jones, Supervisor

ATTEST: \_\_\_\_\_  
Peter Gialamas, Township Clerk

**Exhibit A**

Resolution of the Maine Township Electors

[Attached]

**MAINE TOWNSHIP**

**ANNUAL TOWN MEETING OF ELECTORS  
April 14, 2026**

**RESOLUTION NO. 2026-4**

**A RESOLUTION OF THE MAINE TOWNSHIP  
ELECTORS AUTHORIZING THE PURCHASE OF CERTAIN  
PROPERTY LOCATED AT 9850 MILWAUKEE AVENUE FROM CHICAGO TITLE LAND  
TRUST COMPANY**

**WHEREAS**, Maine Township ("**Township**") is a unit of local government operating under the laws of the State of Illinois; and

**WHEREAS**, Section 1/30-50(a) of the Illinois Township Code (60 ILCS 1/30-50(a)), authorizes the electors of the Township to make all orders for the purchase of property, including real property, that may be deemed conducive to the interests of its inhabitants; and

**WHEREAS**, Section 1/30-20 of the Illinois Township Code (60 ILCS 1/30-20), delineates that such power of the electors so designated in Section 30-50(a) of the Illinois Township Code is applicable at the Township's annual meeting of electors; and

**WHEREAS**, Chicago Title Land Trust Company ("Chicago Title"), an Illinois land trust corporation, has expressed interest in selling certain real property to located at 9850 Milwaukee Ave, Glenview, Illinois, legally described in the Exhibit A ("Property"); and

**WHEREAS**, the Township, by its electors, wishes to acquire the Property for use as the Township's food pantry and for other public purposes; and

**WHEREAS**, the Township, by its electors, finds that it is in the best interests of the Township to purchase the Property from Chicago Title in accordance with this Resolution's terms.

**NOW, THEREFORE, BE IT RESOLVED** by the electors of Maine Township, Cook County, Illinois at the Annual Township Meeting held on April 14, 2026, as follows:

**Section 1.** The Property legally described on Exhibit A is hereby authorized to be purchased by the Township Board from Chicago Title for an amount not to exceed funds the Township currently has in the town fund and/or capital reserves and without imposing any new or

higher taxes to fund the purchase price.

**Section 2.** Upon formal adoption and execution of this Resolution Authorizing the Purchase of Real Property, the electors of the Township hereby authorize and direct the Township Board to enter into a real estate purchase and sale agreement (“Agreement”) for the purchase of the Property not to exceed the Purchase Price.

**Section 3.** The Township Supervisor, Clerk, Board, and Attorney are hereby directed and empowered to take any and all actions necessary to effectuate the purchase of the Property and to execute the Agreement pursuant to any and all requirements set forth in the Township Code.

**Section 4.** In the event that Chicago Title and the Township Board are not able to reach an agreement on a purchase price for the Property, the Township shall have no obligation to purchase the property.

**Section 5.** If any section, paragraph, clause, or provision of this Resolution shall be held invalid, the validity thereof shall not affect any of the other provisions of this Resolution.

**Section 6.** All resolutions in conflict herewith are hereby repealed to the extent of such conflict.

**Section 7.** This Resolution shall be in full force and effect from after its passage and approval as provided by law.

[Intentionally left blank]

AYES:

NAYES:

APPROVED this \_\_\_\_ day of April, 2026.

**MAINE TOWNSHIP**

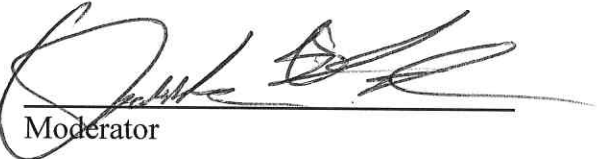
  
\_\_\_\_\_  
Moderator

ATTEST:   
\_\_\_\_\_  
Township Clerk

Exhibit A

**Property's Legal Description**

THAT PART OF LOT 3 IN GOLF MILL INVESTMENTS SUBDIVISION, BEING A SUBDIVISION OF PART OF THE WEST 1/2 OF THE SOUTH WEST 1/4 OF SECTION 11, TOWNSHIP 41 NORTH, RANGE 12 EAST OF THE THIRD PRINCIPAL MERIDIAN DESCRIBED AS FOLLOWS:

BEGINNING AT THE SOUTH CORNER OF LOT 3 THENCE NORTHWESTERLY ALONG THE NORTHEASTERLY LINE OF LOT 3, 150.0 FEET THENCE SOUTHWESTERLY AT RIGHT ANGLES TO MILWAUKEE AVENUE 300.00 FEET; THENCE SOUTHEASTERLY AT RIGHT ANGLES TO LAST DESCRIBED COURSE, 166.20 FEET TO A POINT ON THE SOUTHEASTERLY LINE OF LOT 3; THENCE NORTHEASTERLY ALONG THE SOUTHEASTERLY LINE OF LOT 3, BEING PERPENDICULAR TO THE RIGHT OF WAY LINE OF THE COMMONWEALTH EDISON COMPANY A DISTANCE OF 37.74 FEET; THENCE NORTHEASTERLY 265.91 FEET TO THE PLACE OF BEGINNING, ACCORDING TO THE PLAT THEREOF RECORDED NOVEMBER 25, 1975 AS DOC. NO. 23304613, IN COOK COUNTY, ILLINOIS.

P.I.N.: 09-11-300-061-0000

Address: 9850 Milwaukee Ave, Glenview, Illinois

**Exhibit B**

Purchase and Sale Agreement with Chicago Title

[Attached]

**PURCHASE AND SALE AGREEMENT**

**THIS PURCHASE AND SALE AGREEMENT (“Agreement”)** is made and entered into as of this \_\_\_\_ day of \_\_\_\_\_, 2026 (“**Effective Date**”), between **MAINE TOWNSHIP**, an Illinois township with offices located at 1700 Ballard Road, Park Ridge, Illinois (“**Buyer**”), and **THE LAND TRUST COMPANY f/k/a Chicago Title Land Trust Company** with offices located at 35 W Wacker, Chicago, Illinois (“**Seller**”) (collectively, the Buyer and Seller are the “**Parties**” and individually a “**Party**”).

**RECITALS**

**WHEREAS**, the Seller owns a certain parcels of real property containing, in total, +/- 12,000 square feet commonly known as 9850 Milwaukee Avenue located in Glenview, Illinois, which real property is legally described in Exhibit A (“**Seller’s Land**”); and

**WHEREAS**, the Seller’s Land is currently improved with +/-12,000 square foot commercial structure and related infrastructure, improvements, and appurtenances (collectively, “**Improvements**”) (collectively, the Seller’s Land and the Improvements are the “**Property**”); and

**WHEREAS**, the Illinois Township Code (60 ILCS 1/85-10(c)) and other statutory law authorize the Buyer to acquire the Property from the Seller; and

**WHEREAS**, at the Township’s annual town meeting on April 14, 2026, the Township’s electors authorized the Township Board to purchase the Property; and

**WHEREAS**, the Buyer wishes to acquire the Property from the Seller, and the Seller wishes to convey the Property to the Buyer, all in accordance with and subject to this Agreement’s terms;

**AGREEMENT**

In consideration of the recitals, covenants, and agreements contained herein, the Parties agree as follows:

**1. Recitals and Exhibits; Property to be Purchased.**

(a) The foregoing recitals and exhibits attached to this Agreement are incorporated as though fully set forth in this Section.

(b) Subject to this Agreement’s terms and conditions, Seller agrees to convey to Buyer and Buyer agrees to purchase from Seller the Property together with all personal property remaining on the Property on the Closing Date (as defined in Section 4 below).

**2. Purchase Price.** The purchase price for the Property shall be **ONE MILLION TWO HUNDRED THOUSAND AND NO 100ths (\$1,200,000.00) DOLLARS** (“**Purchase Price**”). Buyer shall pay the Purchase Price at Closing, minus any credits provided by Seller or

authorized by this Agreement. Buyer represents and warrants that this is a cash deal and that the Buyer will not use third-party financing to pay at the Purchase Price or any portion thereof.

**3. Earnest Money.** Buyer will deliver, within five (5) business days of the Effective Date, a check or wire transfer in the amount of **TWENTY THOUSAND AND NO 100ths (\$20,000.00) DOLLARS** to Precision Title Company, an agent of Fidelity National Title Insurance Company (“**Title Company**”) (the money delivered to the Title Company, together with interest thereon and all other deposits hereafter made by Buyer pursuant to this Agreement, is hereinafter referred to as the “**Earnest Money**”), to be held and disbursed by the Title Company in accordance with the terms of a strict joint order escrow agreement in a form acceptable to the Parties. The Earnest Money plus any interest accrued shall be applied to the Purchase Price to be paid by Buyer at Closing (as defined in Section 4 below). Except as provided in this Agreement, the Earnest Money shall be nonrefundable and shall be retained by the Seller should the Buyer fail to purchase the Property.

**4. Closing.** The Buyer will schedule a closing of the Property’s purchase and sale (“**Closing**”) to take place after the Inspection Period as set forth in Section 5 below, but before July 10, 2026. The Closing will be at a mutually agreeable time at the offices of the Title Company, or such other place and time as may be agreed to by the Parties.

**5. Inspection Contingency.**

(a) Inspections. Beginning on the Effective Date and ending forty-five (45) calendar days thereafter (“**Inspection Period**”), Buyer and its employees, agents, contractors, consultants, representatives and designees shall, at Buyer’s sole expense, have the right to examine and test the interior and exterior of the Property, including, without limitation, all structures, mechanical systems, and utilities located thereon, and shall further have the right of reasonable ingress and egress with twenty-four (24) hour advance notice to, and cooperation of, Seller for the purpose of making or conducting all studies, tests, assessments of the surface and subsurface conditions and other tests, examinations, explorations and inspections as Buyer deems appropriate, including, but not limited to, the right to core drill upon, and to remove samples of stone and soil from the Property (collectively, “**Inspection Work**”). During the Inspection Period, Buyer shall have the further right to make such inquiries of governmental agencies and utility companies, and to make such feasibility studies and analyses as it considers appropriate, and to apply for and obtain all necessary regulatory approvals from any local, state, or federal governmental entity or agency necessary for the Buyer’s development, use, and operation of the Property. Seller will cooperate with Buyer with respect to all inspections and regulatory approval processes, including but not limited to the execution of any documents reasonably necessary for such inspections and participation in the regulatory approval processes. Upon the voluntary or involuntary termination of the Inspection Period, Buyer shall return the Property to its condition as it existed upon the Effective Date, reasonable wear and tear excepted.

(b) Right of Termination. The Buyer’s obligations under this Agreement are subject to and conditioned upon the determination by Buyer, in its sole discretion and judgment, that the Property is in satisfactory condition for the Buyer’s purposes. In the event such conditions to Buyer’s obligations have not been satisfied within the Inspection Period, as determined solely by Buyer, Buyer shall have the right, by written notice delivered to Seller on or before the last day

of the Inspection Period, to terminate this Agreement for any reason, or no reason at all. Should such termination be delivered on or before the end of the Inspection Period, this Agreement shall be deemed null and void, neither Party shall have any further rights and obligations under this Agreement, and, in the event of such termination, the Earnest Money shall be promptly returned to the Buyer.

## 6. Survey and Title Review.

(a) Receipt of Survey and Title Commitment. Seller, at its sole expense, shall obtain and deliver to Buyer (i) no later than ten (10) business days after the Effective Date, an ALTA title insurance commitment issued by the Title Company showing the condition of title to the Property (“**Title Commitment**”), together with copies of all recorded documents listed or disclosed therein (“**Recorded Documents**”); and (ii) if required by the Title Company, no later than twenty (20) business days after the Effective Date, an ALTA Survey of the Property dated no more than sixty (60) calendar days before the Effective Date (“**Survey**”). The Survey will depict all Improvements on the Seller’s Land, certify that no portion of the Seller’s Land lies within the 100 year flood plain or has been designated as part of flood zones “A” or “B” by the Federal Emergency Management Agency, demonstrate that Seller’s Land is free from all encroachments, establish and depict the exact perimeter legal description of the Seller’s Land, and include the exact acreage of the Seller’s Land.

(b) Objections. Buyer shall have until ten (10) business days after the delivery of the last of the Survey, the Title Commitment, and the Recorded Documents to examine the same and to provide written objections to Seller of matters set forth on the Survey and/or the Title Commitment that are unsuitable or make the Property undesirable for Buyer’s purposes (collectively, the “**Objections**”).

(c) Cure Period. If Buyer gives timely written notice of its Objections, Seller will (i) notify Buyer in writing within five (5) calendar days after receipt of Buyer’s Objections as to Seller’s proposed steps to cure such Objections, and (ii) take reasonable steps to cure Buyer’s Objections for a period of ten (10) calendar days following receipt by Seller of Buyer’s Objections (“**Cure Period**”).

(d) Failure to Cure. In the event Seller is unable to cure any one or more of Buyer’s Objections within the Cure Period, Buyer’s remedy under this Agreement shall be to either: (i) terminate this Agreement, in which event the Earnest Money will be promptly returned to the Buyer and the Parties shall have no further right or obligation under this Agreement (except for rights or obligations which expressly survive the termination of this Agreement); or (ii) waive the Objections and continue the purchase contemplated by this Agreement. Buyer must provide written notice to Seller of its election to either terminate this Agreement or to waive the Objections not later than ten (10) days after the expiration of the Cure Period.

(e) Seller Deliveries. By no later than five (5) calendar days after the Effective Date, Seller shall deliver all relevant documents in Seller’s possession or under Seller’s control concerning the Property, including, without limitation:

- 1) All contracts related to or concerning the Property;

- 2) Rent Roll;
- 3) All notices of changes in assessed valuation relating to the Property for the current or subsequent tax year, if any, in possession of the Seller, and the current real estate tax bill(s) for the Property;
- 4) All utility statements and invoices for the past year, including, without limitation, invoices related to electricity, gas, water, and wastewater;
- 5) All insurance policies insuring the Property which may be assumed by the Buyer;
- 6) All environmental reports and assessments concerning or implicating the Property; and
- 7) All violation notices concerning or involving the Property including, without limitation, building, zoning, environmental, and health code violations.
- 8) All documents related to or involving pending lawsuits involving the Property or the Seller's interest in the Property.

Seller agrees to cooperate in all respects to facilitate the Inspection Work and agrees to make available all documents, books and records necessary to permit the inspections described herein and, to the extent such records are available and in the Seller's possession, upon Purchaser's reasonable request.

**7. Control of Property.** Prior to the Closing, Seller shall have the full responsibility and liability for any and all damages or injury to the Property. If, prior to the Closing Date, the Property is materially damaged or the Property is the subject of an action in eminent domain or a proposed taking by a governmental authority, whether temporary or permanent, Buyer, at its sole discretion, shall have the right to terminate this Agreement upon notice to Seller by so notifying Seller. If Buyer exercises its right of termination, the Earnest Money will be promptly returned to the Buyer. If Buyer does not exercise its right of termination, any and all proceeds arising out of such damage or destruction, if the same be insured, or out of any such eminent domain or taking, shall be paid to the Buyer on the Closing Date.

**8. Representations.** To induce Buyer to enter into this Agreement, Seller represents, warrants, and covenants to Buyer as set forth below, which representations, warranties, and covenants shall be deemed remade on the Closing Date.

(a) Seller is an Illinois land trust in good standing. Seller has the full right, power, and authority to enter into this Agreement, to perform under this Agreement, and to consummate the transactions contemplated by this Agreement, and the consummation of the

transactions contemplated by this Agreement will not violate any other agreement to which Seller is a party.

(b) This Agreement has been duly authorized, executed and delivered by Seller, creates legal, valid and binding obligations of Seller, and does not violate and will not conflict with or result in a breach of any of the terms or provisions of, or constitute a default under, any judicial order, agreement, arrangements, understanding, accord, document or instrument by which Seller or the Property is bound.

(c) No consent, waiver, approval, or authorization is required from any person or entity in connection with the execution, delivery, and performance of this Agreement by Seller.

(d) Seller has not received any written notice of a pending action, suit, arbitration, unsatisfied order or judgment, government investigation or proceeding (including, without limitation, condemnation or eminent domain proceedings) nor, to Seller's knowledge, has any such investigation or proceeding been threatened against Seller or the Property, in any case that would materially impair Seller's ability to consummate the transactions in the manner required by this Agreement.

(e) To the best of Seller's knowledge, the Property is not subject to any easements, covenants, conditions, restrictions, agreements, liens, or encumbrances that are not of record.

(f) To the best of Seller's knowledge, the Property is not a part of an association or other common ownership regime except as may be otherwise disclosed by the Title Commitment.

(g) Seller has not entered into any contract, agreement or option that remains in effect, other than this Agreement, granting to any party the right to purchase the Property.

(h) Seller has not received any written notice from any municipal, county, state or other governmental authority of any ongoing violation of any statutes, codes, ordinances, rules or regulations with respect to the Property.

(i) Seller is not a party to any unwritten leases of any interest in the Property, or any unwritten contract, operating arrangement or other agreement affecting the ownership, use or operation of the Property that could be binding upon Buyer after Closing, and Buyer shall have the exclusive right to possession of the Property after Closing.

(j) There is no other agreement, written or oral, under which Seller is or could become obligated to convey, lease or license the Property or any interest therein, to a third party,

and Seller will not enter into any such agreement before Closing without the prior written consent of Buyer.

(k) To the best of Seller's knowledge, there are no, and Seller shall not initiate or participate in any, changes in zoning for the Property proposed by any applicable zoning authority unless requested to do so by Buyer.

(l) Seller is not a "foreign person" as that term is defined in Section 1445 of the Internal Revenue Code.

(m) No tenants occupy the Property.

(n) No Hazardous Substance (as defined below) has been generated, stored, released, discharged or disposed of, from or on the Property in violation of any Environmental Law (as defined below). "**Hazardous Substance**" shall mean any and all pollutants, contaminants, toxic or hazardous wastes or any other substances that might pose a hazard to health or safety, the removal of which may be required or the generation, manufacture, refining, production, processing, treatment, storage, handling, transportation, transfer, use, disposal, release, discharge, spillage, seepage or filtration of which is or shall be restricted, prohibited or penalized under any Environmental Law. "**Environmental Law**" shall mean any law, ordinance, rule, regulation, order, judgment, injunction or decree relating to pollution or substances or materials which are considered to be hazardous or toxic, including, without limitation, the Resource Conservation and Recovery Act, the Comprehensive Environmental Response, Compensation and Liability Act, the Hazardous Materials Transportation Act, the Clean Water Act, the Toxic Substances Control Act, the Emergency Planning and Community Right to Know Act, and any state and local environmental law.

(o) Seller is in compliance with the requirements of Executive Order No. 133224, 66 Fed Reg. 49079 (September 25, 2001) ("**Order**") and other similar requirements contained in the rules and regulations of the Office of Foreign Asset Control, Department of the Treasury ("**OFAC**") and in any enabling legislation or other Executive Orders in respect thereof (the Order and such other rules, regulations, legislation, or orders are collectively called the "**Orders**"). Neither Seller nor any beneficial owner of Seller is listed on the Specially Designated Nationals and Blocked Persons List maintained by OFAC pursuant to the Order and/or on any other list of terrorists or terrorist organizations maintained pursuant to any of the rules and regulations of OFAC or pursuant to any other applicable Orders.

(p) Seller has good and marketable title to all items of personal property located on the Property free and clear of all liens, claims, and encumbrances.

Notwithstanding any provisions to the contrary herein, the representations and warranties of Seller contained in this Section 8 shall survive the Closing for a period of one (1) year (Seller hereby agreeing to indemnify and hold harmless Buyer and Buyer's affiliates from any and all liabilities, costs, damages and expenses arising from or related to the breach of any such representations or warranties, as to conditions existing prior to the Closing Date, for such period ending one (1) year after the Closing Date), at which time such representations and warranties (and

such indemnity obligation) shall terminate and be of no further force or effect, except for any claims made prior to the end of such 1-year period.

**9. Representations and Warranties of Buyer.** Buyer hereby represents and warrants to Seller that, as of the Effective Date and deemed to be remade on the Closing Date:

a. Buyer has the full right, power and authority to enter into this Agreement, to perform under this Agreement, and to consummate the transactions contemplated by this Agreement and the consummation of the transactions contemplated by this Agreement will not violate any other agreement to which Buyer is a party.

b. This Agreement has been duly authorized, executed and delivered by Buyer, creates legal, valid and binding obligations of Buyer, and does not violate and will not conflict with or result in a breach of any of the terms or provisions of, or constitute a default under, any judicial order, agreement, arrangements, understanding, accord, document or instrument by which Buyer is bound.

c. Buyer has obtained the applicable consent, waiver, approval or authorization required from any person(s) or entity in connection with the execution, delivery and performance of this Agreement by Buyer.

d. Buyer is in compliance with the requirements of the Orders. Neither Buyer nor any beneficial owner of Buyer is listed on the Specially Designated Nationals and Blocked Persons List maintained by OFAC pursuant to the Order and/or on any other list of terrorists or terrorist organizations maintained pursuant to any of the rules and regulations of OFAC or pursuant to any other applicable Orders.

Notwithstanding any provisions to the contrary herein, the representations and warranties of Buyer contained in this Section 9 shall survive the Closing for a period of one (1) year (Buyer hereby agreeing to indemnify and hold harmless Seller from any and all liabilities, costs, damages and expenses arising from or related to the breach of any such representations or warranties, as to conditions existing prior to the Closing Date, for such period ending one (1) year after the Closing Date), at which time such representations and warranties (and such indemnity obligation) shall terminate and be of no further force or effect, except for any claims made prior to the end of such 1-year period.

**10. Closing Conditions.**

(a) Buyer Closing Conditions. Buyer's obligations under this Agreement are contingent upon satisfaction or waiver of the following conditions (collectively, "**Buyer Closing Conditions**"):

(i) Each and every representation, warranty, and covenant of Seller expressed in this Agreement shall be true, complete and accurate in all material respects as of the Closing Date;

(ii) As of the Closing Date, Seller shall have kept, observed, performed, satisfied and complied with all material terms, covenants, conditions, agreements, requirements, restrictions and provisions required by this Agreement to be kept, observed, performed, satisfied or complied with by Seller in all material respects;

(iii) Seller shall not be a party to or the subject of any pending or threatened actions, suits, arbitrations, claims, attachments, proceedings, assignments for the benefit of creditors, insolvency, bankruptcy, reorganization or other proceedings, that would materially and adversely affect Seller's ability to perform its obligations under this Agreement; and

(iv) The issuance by Title Company of an ALTA owner's title insurance policy, or a "marked up" written commitment unconditionally obligating the Title Company to issue an ALTA owner's title insurance policy, pursuant to the terms of the Title Commitment, with such changes thereto as were negotiated between Buyer and the Title Company during the Inspection Period, in the amount of the Purchase Price, subject only to the Objections waived by the Buyer (if any), to be dated as of the recording of the Deed, naming Buyer (or its assignee) as the insured ("**Title Policy**").

(b) Failure of the Buyer Closing Conditions. If one or more of the Buyer Closing Conditions has not been satisfied on or before the Closing Date, and the same is not due to a default by Buyer under this Agreement, then Buyer may elect to terminate this Agreement by written notice to Seller on or before the Closing Date, in which event the Earnest Money shall be promptly returned to the Buyer and the Parties shall have no further right or obligation under this Agreement (except for rights or obligations which expressly survive the termination of this Agreement), provided that Buyer may, with Seller's consent, extend the Closing Date allow additional time for the satisfaction of any such unsatisfied conditions. Buyer shall have the right to unilaterally waive the Buyer Closing Conditions by proceeding to and consummating Closing. Nothing in the foregoing shall limit or otherwise affect Buyer's rights or remedies under this Agreement.

(c) Seller Closing Conditions. Seller's obligations under this Agreement are contingent upon satisfaction or waiver of the following conditions (collectively, "**Seller Closing Conditions**"):

(i) Each and every representation, warranty, and covenant of Buyer expressed in this Agreement shall be true, complete and accurate in all material respects as of the Closing Date; and

(ii) As of the Closing Date, Buyer shall have kept, observed, performed, satisfied and complied with all material terms, covenants, conditions, agreements, requirements, restrictions and provisions required by this Agreement to be kept, observed, performed, satisfied or complied with by Buyer in all material respects.

(d) Failure of the Seller Closing Conditions. If one or more of the Seller Closing Conditions has not been satisfied on or before the Closing Date, and the same is not due to a default by Seller under this Agreement, then Seller may elect to terminate this Agreement by written notice

to Buyer on or before the Closing Date, in which event the Earnest Money shall be retained by Seller and the Parties shall have no further right or obligation under this Agreement (except for rights or obligations which expressly survive the termination of this Agreement), provided that Seller may extend the Closing Date to allow additional time for the satisfaction of any such unsatisfied conditions. Seller shall have the right to unilaterally waive the Seller Closing Conditions by proceeding to and consummating Closing. Nothing in the foregoing shall limit or otherwise affect Seller's rights or remedies under this Agreement.

**11. Taxes.** All real estate taxes and any special assessment imposed on the Property (“**Taxes**”) for the year in which the Closing occurs shall be prorated and adjusted to the Closing Date. Seller shall pay (or cause to be paid) all Taxes due and payable on or prior to the Closing Date. Buyer shall receive a credit prorated in accordance with this Section for all unbilled Taxes and the amount of the credit shall be calculated based on one hundred (100%) percent of the most recent ascertainable full year real estate tax bill for the Property. All pro-rations will be on the basis of a 366-day year with the Closing Date being charged to the Seller. The proration of Taxes shall be final.

**12. Utilities.** Seller will obtain as close to the Closing Date as practicable final meter readings for utilities serving the Property and will pay final utility invoices, and Buyer will be responsible to open new accounts and pay such charges for the Closing Date and thereafter.

**13. Closing Deliveries and Costs.**

(a) Seller's Deliveries. At the Closing, Seller shall deliver the following to Buyer:

(i) A signed duly recordable warranty deed for the Property with all required stamps affixed, at Seller's sole cost and expense, conveying fee simple title to the Property and all of Seller's rights appurtenant thereto, subject only to the waived Objections, if any (“**Deed**”).

(ii) A bill of sale for the personal property.

(iii) An affidavit certifying to Buyer that Seller is not a “foreign person” within the meaning of Sections 1445 or 7701 of the Internal Revenue Code.

(iv) An affidavit certifying that there is no property manager at the Property.

(v) An ALTA Statement and gap indemnity sufficient to permit the title insurance company to delete the so called “standard exceptions” to the Title Policy and to date the Title Policy no earlier than the date and time of recordation of the Deed.

(vi) Affidavit of Title executed by Seller warranting that no outstanding mechanic's lien rights exist and that the property is subject to no leases, liens, or other claims or encumbrances of title except those specifically permitted pursuant to this Agreement.

(vii) The MyDec form and any other transfer tax forms required in connection with the Closing requiring Seller's signature.

(viii) Proof of payment of all outstanding utility fees and charges concerning or related to the Property.

(ix) Satisfactory evidence of the authority of the signers of the conveyance documents to consummate the transactions on behalf of Seller.

(x) A lien waiver executed by Seller's Broker (as defined in Section 17 below).

(xi) A closing statement executed by Seller in a form mutually acceptable to Seller and Buyer.

(xii) Such other documents as may be required by the terms of this Agreement or by the Title Company, or as may reasonably be necessary in order to consummate the transactions contemplated by this Agreement.

All of the documents and instruments referenced in this Section 13(a) shall be in a form reasonably acceptable to Buyer.

(b) Buyer's Deliveries. At the Closing, Buyer shall deliver the following to Seller:

(i) The Purchase Price less the Earnest Money and any prorations.

(ii) A closing statement executed by Buyer in a form mutually acceptable to Seller and Buyer.

(iii) Any transfer tax forms required in connection with the Closing requiring Buyer's signature.

(iv) Such other documents as may be required by the terms of this Agreement or by the Title Company, or as may reasonably be necessary in order to consummate the transactions contemplated by this Agreement.

(v) An ALTA Statement and gap indemnity sufficient to permit the title insurance company to delete the so called "standard exceptions" to the Title Policy and to date the Title Policy no earlier than the date and time of recordation of the Deed.

(c) Closing Statement. At the Closing, Seller and Buyer shall each execute a closing statement drafted by the Title Company and in form and content reasonably acceptable to both Buyer and Seller.

(d) Closing Costs.

(i) Seller shall pay Seller's attorneys' fees, Seller's broker fees, the cost of the Survey, the Title Commitment, the premium for the Title Policy (excluding the cost for any endorsements or extended coverage over the so called "standard exceptions" requested by Buyer), one-half of all escrow fees and closing costs charged by the Title Company, and all state, county, and municipal transfer taxes and fees (if any).

(ii) Buyer shall pay Buyer's attorneys' fees, the cost for Buyer's endorsements and extended coverage over the so called "standard exceptions" to the Title Policy, if any, all due diligence costs and expenses, all recording charges for the Deed, and one-half of all escrow fees and closing costs charged by the Title Company.

(iii) Any other costs, expenses, and fees shall be allocated between the Parties as is customary and typical for similar types of transactions for real property in the location in which the Property is located.

**14. Delivery of Possession of Property.** The Seller shall deliver possession of the Property to Buyer at the Closing. At Closing, the Seller shall provide the Buyer will all keys, remotes, access codes, and other information necessary to access the Property and all structures and improvements located thereon. All furniture, fixtures, and equipment on the Property will be in reasonable working order.

**15. Indemnification.** Buyer agrees to indemnify and fully protect, defend, and hold the Seller harmless from and against any and all claims, costs, liens, loss, damages, attorney's fees, and expenses of every kind and nature that may be sustained by or made against the Seller resulting from or arising out of:

(a) Negligent inspections or repairs made by the Buyer or its agents, employees, contractors, successors or assigns; and

(b) The Buyer's use and/or occupancy of the Property before Closing, except to the extent caused by the negligent, willful, or intentional act of the Seller.

**16. Condemnation and Destruction.** If, on the Closing Date, all or any portion of the Property is the subject of a pending or contemplated taking by eminent domain which has not been consummated or if the Property has been damaged or destroyed, Seller shall notify Buyer of such fact and Buyer shall have the right, but not the obligation, to terminate this Agreement, whereupon the Earnest Money shall be immediately paid by the Title Company to the Buyer and the rights, duties and obligations of the Parties shall terminate and be of no further force or effect (provided, however, the Parties shall continue to have those rights and obligations which are expressly stated in this Agreement to survive termination). If, after receipt of Seller's notice, Buyer does not exercise its option to terminate this Agreement, the Parties shall remain bound hereunder and Seller shall assign and turn over, and Buyer shall be entitled to receive and keep, all awards for the taking by eminent domain described in said notice or all insurance proceeds payable as a result of such destruction or damage

**17. Brokerage Fees and Commissions.** In the event Seller has contracted with any real estate broker, agent, finder or similar person in connection with the negotiation and execution of this Agreement (“Seller’s Broker”), the transactions contemplated hereby or the sale and purchase of the Property, Seller shall pay the Seller’s Broker at Closing per separate agreement, and Seller shall indemnify, defend, and hold Buyer harmless from and against any commission or other payment due to, or sought by, Seller’s Broker in connection with this matter. Buyer has not contracted with any real estate broker, agent, finder or similar person in connection with the negotiation and execution of this Agreement, the transactions contemplated hereby or the sale and purchase of the Property. It is agreed that if any claim for any brokerage fees other than from the Seller’s Broker is ever made against Seller or Buyer in connection with the transactions contemplated by this Agreement, all such claims shall be paid by the party whose commitments form the basis of such claims. Seller and Buyer agree to indemnify and hold harmless the other from and against any and all liabilities, claims, demands or actions for or with respect to any brokerage fees asserted by any person, firm or corporation in connection with this Agreement or the transactions contemplated hereby, and any court costs, attorneys' fees or other costs and expenses arising therefrom, insofar as any such liabilities, claims, demands or actions are based upon a contract or commitment of the indemnifying party. The provisions set forth in this Section 17 shall survive Closing.

**18. Remedies.** Notwithstanding anything to the contrary set forth in this Agreement or in any document delivered in connection with the transaction contemplated by this Agreement, the Parties agree that if Seller fails to comply with any of the provisions of this Agreement beyond any applicable cure period, Buyer shall have no adequate remedy at law. Accordingly, if Seller fails to comply with any provisions of this Agreement, Buyer shall have the right to either: (i) terminate this Agreement and receive an immediate refund of the Earnest Money; or (ii) obtain specific performance of Seller’s obligation to convey the Property. In addition to the foregoing, Buyer shall be entitled to pursue any other rights or remedies provided in this Agreement, together with those available to it at law or in equity, including the right to monetary damages, upon the failure of Seller to carry out any of its obligations under this Agreement. If Buyer fails to comply with the terms of this Agreement beyond any applicable cure period, Seller’s sole and exclusive remedy shall be the retention of the Earnest Money.

**19. Miscellaneous.**

(a) No Waiver. The waiver by either Party hereto of any condition or the breach of any term, covenant or condition herein contained shall not be deemed to be a waiver of any other condition or of any subsequent breach of the same or of any other term, covenant or condition herein contained. Either Party, exercising its sole discretion, may waive any right conferred upon such Party by this Agreement; provided that such waiver shall only be made by giving the other Party written notice specifically describing the right waived.

(b) Time of Essence. Time is of the essence of this Agreement.

(c) Governing Law. This Agreement is made and executed under and in all respects to be governed and construed by the laws of the State of Illinois and the Parties hereby

agree and consent and submit themselves to any court of competent jurisdiction situated in the County of Cook, State of Illinois.

(d) Notices. All notices and demands given or required to be given by any Party hereto to any other Party shall be deemed to have been properly given if and when delivered in person, sent by email, or 3 business days after having been deposited in any U.S. Postal Service and sent by registered or certified mail, postage prepaid, addressed as follows (or sent to such other address as any Party shall specify to the other Party pursuant to the provisions of this Section):

**If to Seller:**

Chicago Title Land Trust Company  
Attn: Myungwon Yoo, Beneficiary  
56 Woodland Trail  
Lincolnshire, IL 60069  
Email: [mwkim317@gmail.com](mailto:mwkim317@gmail.com)

**With a copy to:**

Yon S. Choe, Esq.  
8930 Waukegan Rd. Ste. 210  
Morton Grove, IL 60053  
Email: [yscesq@gmail.com](mailto:yscesq@gmail.com)

**If to Buyer:**

Maine Township  
Attn: Victoria Rizzo, Township Administrator  
1700 Ballard Road  
Park Ridge, Illinois 60068  
Email: [vrizzo@mainetown.com](mailto:vrizzo@mainetown.com)

**With a copy to:**

Ancel Glink, P.C.  
Attn: Kurt S. Asprooth  
140 S. Dearborn Street, 6th Floor  
Chicago, Illinois 60603  
Email: [kasprooth@ancelglink.com](mailto:kasprooth@ancelglink.com)

In the event either Party delivers a notice by email, as set forth above, such Party agrees to deposit the originals of the notice in a post office, branch post office, or mail depository maintained by the U.S. Postal Service, postage prepaid and addressed as set forth above. Such deposit in the U.S. Mail shall not affect the deemed delivery of the notice by email, provided that the procedures set forth above are fully complied with. Any Party, by notice given as aforesaid, may change the address to which subsequent notices are to be sent to such Party.

(e) Assignment, Successors and Assigns. This Agreement, including, without limitation, any of a Party's rights or obligations hereunder, may not be assigned by either Party without the consent of the other Party.

(f) Severability. If for any reason any term or provision of this Agreement shall be declared void and unenforceable by any court with jurisdiction over this Agreement, it shall only affect such particular term or provision of this Agreement and the balance of this Agreement shall remain in full force and effect and shall be binding upon the Parties.

(g) Complete Agreement. All understandings and agreements heretofore had between the Parties are merged into this Agreement which alone fully and completely expressed their agreement. This Agreement may be amended or modified only in a writing signed by both Parties, shall apply to and bind the permitted successors and assigns of each of the Parties, and shall merge with the Deed at Closing, excluding those provisions that this Agreement provides will survive Closing.

(h) No Third-Party Beneficiaries. The covenants and agreements contained herein shall be binding upon and inure to the sole benefit of the Parties and their successors and assigns. Nothing herein, express or implied, is intended to or shall confer upon any other person, entity, company, or organization, any legal or equitable right, benefit or remedy of any nature whatsoever under or by reason of this Agreement.

(i) Attorneys' Fees. If any action is brought by either Party arising from, or related to, this Agreement, then the prevailing Party shall be entitled to receive from the non-prevailing Party its actual court costs and reasonable attorney's fees incurred. This Section shall survive Closing or any earlier termination of this Agreement.

(j) Calculation of Days. In the event that any date described in this Agreement for the performance of an action required hereunder by Seller and/or Buyer falls on a Saturday, Sunday or federal legal holiday, such date shall be deemed postponed until the next business day thereafter.

(k) Interpretation. This Agreement and any related instruments shall not be construed more strictly against one Party than against the other by virtue of the fact that initial drafts were made and prepared by counsel for one of the Parties, it being recognized that this Agreement and any related instruments are the product of extensive negotiations between the Parties hereto and that both Parties hereto have contributed substantially and materially to the final preparation of this Agreement and all related instruments.

(l) Counterparts. This Agreement may be executed in any number of counterparts, each of which shall be deemed an original, but all of which together shall constitute one and the same instrument, and any signatures to counterparts may be delivered by facsimile or other electronic transmission and shall have the same force and effect as original signatures.

**IN WITNESS WHEREOF**, the Parties hereto have executed this Agreement as of the Effective Date.

**MAINE TOWNSHIP,**  
an Illinois township

**Attest:**

\_\_\_\_\_  
Name:

\_\_\_\_\_  
Name:

\_\_\_\_\_  
Title:

\_\_\_\_\_  
Title:

\_\_\_\_\_  
Date:

\_\_\_\_\_  
Date:

**CHICAGO TITLE LAND TRUST COMPANY,**  
an Illinois corporation, Trust Number 8002347223

By \_\_\_\_\_  
Myungwon Yoo, Beneficiary

\_\_\_\_\_  
Date:

Exhibit A

**Legal Description**

THAT PART OF LOT 3 IN GOLF MILL INVESTMENTS SUBDIVISION, BEING A SUBDIVISION OF PART OF THE WEST 1/2 OF THE SOUTH WEST 1/4 OF SECTION 11, TOWNSHIP 41 NORTH, RANGE 12 EAST OF THE THIRD PRINCIPAL MERIDIAN DESCRIBED AS FOLLOWS:

BEGINNING AT THE SOUTH CORNER OF LOT 3 THENCE NORTHWESTERLY ALONG THE NORTHEASTERLY LINE OF LOT 3, 150.0 FEET THENCE SOUTHWESTERLY AT RIGHT ANGLES TO MILWAUKEE AVENUE 300.00 FEET; THENCE SOUTHEASTERLY AT RIGHT ANGLES TO LAST DESCRIBED COURSE, 166.20 FEET TO A POINT ON THE SOUTHEASTERLY LINE OF LOT 3; THENCE NORTHEASTERLY ALONG THE SOUTHEASTERLY LINE OF LOT 3, BEING PERPENDICULAR TO THE RIGHT OF WAY LINE OF THE COMMONWEALTH EDISON COMPANY A DISTANCE OF 37.74 FEET; THENCE NORTHEASTERLY 265.91 FEET TO THE PLACE OF BEGINNING, ACCORDING TO THE PLAT THEREOF RECORDED NOVEMBER 25, 1975 AS DOC. NO. 23304613, IN COOK COUNTY, ILLINOIS.

P.I.N.: 09-11-300-061-0000

Address: 9850 Milwaukee Ave, Glenview, Illinois



4/28/26

---

**TO:** Elected Officials

**FROM:** Victoria Rizzo, Administrator

---

**SUBJECT:** Town Fund/General Assistance Tentative Budget & Appropriation Ordinance for 2026-27

---

- Discussion & Vote of Town Fund/General Assistance Tentative Budget & Appropriation Ordinance for 2026-27

The tentative budget is available for public review. A public hearing will be held on May 26, 2026, for the adoption of the Town Fund and General Assistance budgets. Each department has thoroughly evaluated projected expenses and revenues for the 2026–2027 fiscal year.

**MAINE TOWNSHIP  
ORDINANCE 2026-1  
TENTATIVE BUDGET & APPROPRIATION ORDINANCE FOR 2026-2027**

for MAINE TOWNSHIP located in the County of Cook, State of Illinois for the fiscal year beginning  
March 1, 2026 and ending February 28, 2027.

Now be it Ordained by the Board of Trustees of MAINE TOWNSHIP, COUNTY OF COOK, STATE OF  
ILLINOIS, in meeting assembled as follows:

Section 1: That the following budget containing an estimate of receipts and expenditures for the  
following funds: GENERAL TOWN AND GENERAL ASSISTANCE FUND is hereby adopted as the  
budget of the township for the fiscal year mentioned above and shall be in full force and effect from and  
after this date.

**GENERAL TOWN FUND**

BEGINNING BALANCE	\$5,554,256
ESTIMATED REVENUES	
Property Tax	\$3,460,000
Replacement Tax	\$120,000
Interest Income	\$135,000
MaineStay Income	\$60,000
Rental Income	\$42,000
Yard Stickers and Rebates	\$5,000
Postage	\$2,500
Transportation Fees	\$300
Hunting/Fishing License	\$1,500
Passport Fees	\$50,000
Other Income	\$22,000
Recovery Connection Appropriation	\$30,000
Grants	\$100,000
License Plate Stickers	\$20,000
<b>TOTAL ESTIMATED REVENUES</b>	<b>\$4,048,300</b>
<b>TOTAL ESTIMATED FUNDS AVAILABLE EXCLUDING MAINSTREAMER PROGRAM FEES</b>	<b>\$9,602,556</b>

<b>BUDGETED EXPENDITURES</b>	
Administration	\$3,847,252
Assessor	\$447,971
Clerk	\$324,850
Emergency Management	\$94,160
MaineStay Youth and Family Services	\$697,900
Mainstreamers Senior Services	\$415,750
<b>TOTAL ESTIMATED EXPENDITURES</b>	<b>\$5,827,883</b>
<b>EXCLUDING MAINSTREAMER PROGRAM FEES</b>	

<b>ENDING BALANCE</b>	<b>\$3,774,673</b>
-----------------------	--------------------

**ADMINISTRATION**

<b>PERSONNEL</b>	
Salaries/Employees	\$655,000
Salaries/Elected Officials	\$195,000
IDES	\$1
Social Security	\$65,000
Municipal Retirement Fund	\$40,000
Health Insurance	\$315,000
Dental Insurance	\$6,500
Life Insurance	\$2,000
Tuition Reimbursement	\$2,000
<b>TOTAL PERSONNEL</b>	<b>\$1,280,501</b>

**CONTRACTUAL SERVICES**

Bookkeeping/Accounting Services	\$55,000
Audit Services	\$16,000
Payroll Services	\$35,000
Building-Grounds Maintenance	\$45,000
Facilities Maintenance	\$30,000
Community Information-Support	\$47,000
Conferences-Meetings	\$2,500
Dues-Subscriptions	\$12,000
Web Site/Email Host	\$25,000
Equipment Leasing-Maintenance	\$17,500
Computer Tech Support	\$5,000
Print Management	\$2,500
General Insurance-Liability-Bond	\$70,000
Legal Services	\$50,000
Mileage-Travel-Lodging Expense	\$5,000
Police Protection	\$55,000
Postage	\$55,000
Printing-Publishing	\$72,000

Special Programs	\$20,000
Staff Training	\$500
Telecommunications	\$25,000
Clean Up/Waste Hauler	\$7,500
Transportation/MaineLines	\$1,500
Utilities	\$35,000
Utilities - Facility 2	\$15,000
<b>TOTAL CONTRACTUAL SERVICES</b>	<u>\$704,000</u>

<b>COMMODITIES</b>	
Miscellaneous	\$750
Office Supplies/Small Equipment	\$15,000
Operating Supplies-Maintenance	\$17,000
Uniforms	\$2,500
<b>TOTAL COMMODITIES</b>	<u>\$35,250</u>

<b>OTHER EXPENDITURES</b>	
Code Enforcement Expense	\$500
National Night Out	\$5,000
Plan Commission	\$1
Maine Township Recovery Connections	\$70,000
Vehicle Expense	\$7,000
<b>TOTAL OTHER EXPENDITURES</b>	<u>\$82,501</u>

<b>CAPITAL OUTLAY</b>	
Building	\$45,000
Building Purchase	\$1,400,000
Capital Fund Account	\$200,000
<b>TOTAL CAPITAL OUTLAY</b>	<u>\$1,645,000</u>

Contingencies	\$100,000
<b>TOTAL ADMINISTRATION</b>	<u>3,847,252</u>

**ASSESSOR**

<b>PERSONNEL</b>	
Salaries	\$270,000
Social Security	\$20,300
Life Insurance	\$300
Dental Insurance	\$2,800
Municipal Retirement Fund	\$17,300
Health Insurance	\$125,000
<b>TOTAL PERSONNEL</b>	<u>\$435,700</u>

<b>CONTRACTUAL SERVICES</b>	
Conferences-Meetings	\$1,300
Cook County Assessor Tie-in	\$1,050
Dues-Subscriptions	\$570
Equipment Leasing-Maintenance	\$1
Mileage-Travel-Lodging Expense	\$1,500
Postage	\$1,200
Printing-Publishing	\$500
Sidwell Maps	\$700
Staff Training	\$150
<b>TOTAL CONTRACTUAL SERVICES</b>	<u>\$6,971</u>

<b>COMMODITIES</b>	
Miscellaneous	\$2,000
Office Supplies/Small Equipment	\$3,300
<b>TOTAL COMMODITIES</b>	<u>\$5,300</u>

<b>TOTAL ASSESSOR</b>	<u>\$447,971</u>
-----------------------	------------------

**CLERK**

<b>PERSONNEL</b>	
Salaries	\$178,000
Social Sec.	\$14,000
Municipal Retirement Fund	\$9,000
Health Insurance	\$73,500
Dental Insurance	\$1,500
Life Insurance	\$350
<b>TOTAL PERSONNEL</b>	<u>\$276,350</u>

<b>CONTRACTUAL SERVICES</b>	
Conferences-Meetings	\$2,000
Dues-Subscriptions	\$500
Print Management	\$2,500
Mileage-Travel-Lodging Expense	\$1,000
Honor Flight	\$1,000
Postage	\$9,000
Printing-Publishing	\$2,200
Computer Tech Support	\$5,000
Staff Training	\$700
Hunting/Fishing License	\$1,000
License Plate Stickers	\$20,000

TOTAL CONTRACTUAL SERVICES	<u>\$44,900</u>
COMMODITIES	
Miscellaneous	\$100
Office Supplies/Small Equipment	<u>\$3,500</u>
TOTAL COMMODITIES	<u>\$3,600</u>
<b>TOTAL CLERK</b>	<u>\$324,850</u>

**OFFICE OF EMERGENCY MANAGEMENT**

PERSONNEL	
Salaries	\$40,000
Social Security	\$3,060
Uniforms	<u>\$4,000</u>
TOTAL PERSONNEL	<u>\$47,060</u>

CONTRACTUAL SERVICES	
Conferences/Meetings	\$500
Dues/Subscriptions	\$400
Utilities	\$4,500
Special Programs	\$1,500
Communications Services	\$3,900
Staff Training	<u>\$1,500</u>
TOTAL CONTRACTUAL SERVICES	<u>\$12,300</u>

COMMODITIES	
Office Supplies/Small Equipment	\$7,500
Operating Supplies	\$4,000
Disaster Operations Supplies	<u>\$3,000</u>
TOTAL COMMODITIES	<u>\$14,500</u>

OTHER EXPENDITURES	
Volunteer Insurance	\$1,000
Vehicle Expense	<u>\$8,500</u>
TOTAL OTHER EXPENDITURES	<u>\$9,500</u>

CAPITAL OUTLAY	
Building	<u>\$10,800</u>
TOTAL CAPITAL OUTLAY	<u>\$10,800</u>

<b>TOTAL OFFICE OF EMERGENCY MANAGEMENT</b>	<u>\$94,160</u>
---	-----------------

## MAINESTAY YOUTH AND FAMILY SERVICES

### PERSONNEL

Salaries	\$420,000
Social Security	\$33,000
Municipal Retirement Fund	\$30,000
Health Insurance	\$132,000
Dental Insurance	\$2,200
Life Insurance	\$650
TOTAL PERSONNEL	<u>\$617,850</u>

### CONTRACTUAL SERVICES

Community Education	\$1,700
Summer Youth Camp	\$18,000
Garage Sale	\$900
Conferences-Meetings	\$800
Dues-Subscriptions/Licensures	\$8,000
Print Management	\$2,500
General Insurance-Liability-Bond	\$900
Mileage-Travel-Lodging Expense	\$1,500
Postage	\$100
Printing-Publishing	\$1,200
Special Programs	\$21,000
Computer Tech Support	\$5,000
Consultation/Staff Training	\$7,000
TOTAL CONTRACTUAL SERVICES	<u>\$68,600</u>

### COMMODITIES

Training Manuals/Books	\$400
Miscellaneous	\$50
Office Supplies/Small Equipment	\$8,000
TOTAL COMMODITIES	<u>\$8,450</u>

### OTHER EXPENDITURES

Youth Recreation Fund	\$3,000
TOTAL OTHER EXPENDITURES	<u>\$3,000</u>

<b>TOTAL MAINESTAY YOUTH AND FAMILY SERVICES</b>	<u><b>\$697,900</b></u>
--	-------------------------

**MAINSTREAMERS SENIOR SERVICES**

PERSONNEL

Salaries	\$315,000
Social Security	\$24,500
Municipal Retirement Fund	\$23,000
Health Insurance	\$11,500
Dental Insurance	\$1,600
Life Insurance	\$400
TOTAL PERSONNEL	<u>\$376,000</u>

CONTRACTUAL SERVICES

Conferences-Meetings	\$900
Dues & Licensing Fee	\$9,000
Mileage-Travel-Lodging Expense	\$2,100
Special Programs	\$10,000
Computer Tech Support	\$4,500
Print Management	\$2,500
Telecommunications	\$750
TOTAL CONTRACTUAL SERVICES	<u>\$29,750</u>

COMMODITIES

Office Supplies/Small Equipment	\$10,000
TOTAL COMMODITIES	<u>\$10,000</u>

<b>TOTAL MAINSTREAMERS SENIOR SERVICES</b>	<u><b>\$415,750</b></u>
--	-------------------------

<b>TOTAL TOWN FUND</b>	<b>\$5,827,883</b>
------------------------	--------------------

**GENERAL ASSISTANCE FUND**

BEGINNING BALANCE	\$2,112,796
ESTIMATED REVENUES	
Property Tax	\$645,000
Social Security Reimbursement	\$24,000
Interest Income	\$60,000
Personal Property Replacement Tax	\$4,610
Energy Assistance Revenue	\$15,000
Other Income	\$500
<b>TOTAL ESTIMATED REVENUES</b>	<u>\$749,110</u>
<b>TOTAL ESTIMATED FUNDS AVAILABLE</b>	\$2,861,906
BUDGETED EXPENDITURES	
Administration	\$1,160,235
Home Relief	\$207,501
<b>TOTAL ESTIMATED EXPENDITURES</b>	<u>\$1,367,736</u>
<b>ENDING BALANCE</b>	\$1,494,170

**ADMINISTRATION**

PERSONNEL	
Salaries	\$420,000
IDES	\$1
Social Security	\$32,130
Municipal Retirement Fund	\$25,000
Health Insurance	\$110,000
Dental Insurance	\$1,500
Life Insurance	\$400
Tuition Reimbursement	\$1
<b>TOTAL PERSONNEL</b>	<u>\$589,032</u>

CONTRACTUAL SERVICES	
Conferences-Meetings	\$800
Accounting Services	\$2,500
Payroll Services	\$9,500
Dues-Subscriptions	\$100
Print Management	\$2,500

General Insurance-Liability-Bond	\$7,500
Hearing Officer	\$1
Legal Services	\$1
Mileage-Travel-Lodging Expense	\$1,000
Postage	\$4,000
Printing-Publishing	\$1,000
Computer Tech Support	\$4,500
Staff Training	\$1,000
PACE	\$9,000
<b>TOTAL CONTRACTUAL SERVICES</b>	<u>\$43,402</u>
<b>FOOD PANTRY</b>	
Food Pantry	\$12,000
<b>TOTAL FOOD PANTRY</b>	<u>\$12,000</u>
<b>COMMODITIES</b>	
Miscellaneous	\$1
Office Supplies/Sm. Equipment	\$3,500
<b>TOTAL COMMODITIES</b>	<u>\$3,501</u>
<b>CAPITAL OUTLAY</b>	
Computer Software Development	\$3,000
<b>TOTAL CAPITAL OUTLAY</b>	<u>\$3,000</u>
<b>AGENCY FUNDING</b>	
Agency Funding	\$499,300
	<u>\$499,300</u>
<b>CONTINGENCY</b>	<u>\$10,000</u>
Contingency	\$10,000
<b>TOTAL ADMINISTRATION</b>	<b>\$1,160,235</b>

## **HOME RELIEF**

<b>CONTRACTUAL SERVICES</b>	
Medical Services	\$500
Ambulance-Paramedic Service	\$1,000
Client Utilities	\$10,000
Dental Services	\$1,000
Emergency Assistance Program	\$7,000
Food	\$60,000
Funeral and Burial Services	\$1
Client Health Insurance	\$500
Prescription Drugs	\$1,500

Shelter-Rent	\$100,000
TOTAL CONTRACTUAL SERVICES	<u>\$181,501</u>
COMMODITIES	
Personal Essentials	\$25,000
Transient	<u>\$1,000</u>
TOTAL COMMODITIES	\$26,000
<b>TOTAL HOME RELIEF</b>	<u><b>\$207,501</b></u>
<b>TOTAL GENERAL ASSISTANCE FUND</b>	<u><b>\$1,367,736</b></u>
<b>1. GENERAL TOWN FUND</b>	\$5,827,883
<b>2. GENERAL ASSISTANCE FUND</b>	\$1,367,736
<b>TOTAL</b>	<u><b>\$7,195,619</b></u>

Section 3: That each total is divided among the several objects and purposes specified and in particular amounts stated for each fund respectfully in Section 1 and Section 2 constituting the total appropriations & ending balance the amount of (\$7,195,619) seven million one hundred ninety five thousand six hundred nineteen the fiscal year March 1, 2026 to February 28, 2027 and that Section 3 shall be and is the annual Appropriation Ordinance of this Township, passed by the Board of Trustees as required by law and shall be in full force effect from and after this date.

Section 4: A certified copy of the Budget & Appropriation Ordinance must be filed with the County Clerk within 30 days after adoption.

Adopted in a meeting assembled on May 26, 2026 by the Board of Trustees of the Town of Maine in the County of Cook, State of Illinois pursuant to a roll call vote as follows:

AYE    NAY    ABSENT    \_\_\_\_\_

AYE    NAY    ABSENT    \_\_\_\_\_

AYE    NAY    ABSENT    \_\_\_\_\_

AYE    NAY    ABSENT    \_\_\_\_\_  
Trustees

AYE    NAY    ABSENT    \_\_\_\_\_  
Supervisor

\_\_\_\_\_  
Clerk



4/28/26

---

**TO:** Elected Officials

**FROM:** Victoria Rizzo, Administrator

---

**SUBJECT:** Amendments to Public Relations Marketing Agreement

---

- Discussion and Possible Vote to Approve Amendments to Public Relations Marketing Agreement

For discussion and possible vote are 2 amendments to the Public Relations and Marketing Agreement with M3 Marketing, LLC. The first provides specific additional services with the Maine Township Highway Department and the second provides for the Mainely News newsletter to be drafted and designed by M3.

## **FIRST AMENDMENT TO PUBLIC RELATIONS AND MARKETING AGREEMENT**

This Amendment (“Amendment”) to the Public Relations and Marketing Agreement dated June 24, 2025 (“Agreement”) is made on \_\_\_\_\_, 2026 by and between MAINE TOWNSHIP of Cook County, Illinois, an Illinois unit of local government, acting through its Authorized Representatives (hereinafter referred to as “TOWNSHIP”), MAINE TOWNSHIP ROAD DISTRICT, acting through its Authorized Representatives (hereinafter referred to as “ROAD DISTRICT”), and M3 MARKETING, LLC, a limited liability company organized pursuant to Illinois law, whose principals are ROBERT FLINN and MARTIN McALPIN (hereinafter referred to as “M3”), hereinafter sometimes referred to as “Party” or collectively as “Parties”.

On or about June 24, 2025, the Parties entered into the Agreement by which M3 provides certain specified services and TOWNSHIP compensates M3, relying on cooperation and good faith between the Parties. This Amendment modifies that Agreement pursuant to Paragraph O.5, by adding a new paragraph H and redesignating the subsequent paragraphs:

### H. *ROAD DISTRICT.*

1. Services. M3 shall provide specific additional services to the ROAD DISTRICT. These services include publishing up to One (1) blog post per month at an estimated Three hundred fifty (350) words per post, up to Three (3) Facebook posts per month, up to One (1) press release per month, and assistance with the annual ROAD DISTRICT community survey. TOWNSHIP will allow M3 access to TOWNSHIP Facebook page, website and other appropriate resources as necessary to provide these services. ROAD DISTRICT will make good faith efforts to respond promptly to inquiries from M3 regarding the content for each post. M3 shall at the ROAD DISTRICT’s request prepare additional blog posts and press releases at the rate of Seventy five dollars even (\$75.00) per hour, subject to M3 availability. If additional costs are to be incurred by ROAD DISTRICT, M3 will follow the procedures under the Payment for Services and Costs provision as provided for in this Amendment. Services performed under this Paragraph H shall not count toward, reduce, or otherwise satisfy any minimum commitments or deliverable requirements set forth in any other paragraph of this Agreement.

2. Payment for Services and Costs. Beginning on June 1, 2026, TOWNSHIP shall pay to M3 One thousand nine hundred fifty dollars (\$1,950.00) per month on or before the last day of each month for the services described in paragraph H.1. The ROAD DISTRICT shall remit the fee to the TOWNSHIP. The TOWNSHIP’s obligation to pay M3 is contingent upon its receipt of such funds; in the event the ROAD DISTRICT fails to remit payment, the TOWNSHIP shall have no obligation to pay M3 for services performed under this paragraph H. TOWNSHIP will own the copyright to any and all written or design work prepared by M3 for TOWNSHIP. In addition to the payments for services, the Parties recognize that M3 may incur certain costs for out-of-pocket expenses and payments to third parties. Schedule B attached to this Agreement outlines the initially anticipated costs, including approximate amounts, which TOWNSHIP agrees to reimburse pursuant to the Local Government Prompt Payment Act (50 ILCS 505/1, et seq), except for such invoices that TOWNSHIP shall pay directly to the invoicing vendor. The Parties shall confirm in writing such payment arrangements to avoid duplication of payments. If M3 subsequently anticipates incurring other costs, to the extent each such cost is less than

**Amendment to Public Relations and Marketing Agreement**  
**Page 2 of 4**

Fifty dollars even (\$50.00), then M3 is authorized to incur such reimbursable expense and TOWNSHIP shall reimburse M3 in accordance with the Local Government Prompt Payment Act. M3 shall not incur any individual expense in excess of fifty dollars (\$50.00) without prior written approval from the Township.

In all other respects, the Parties affirm and republish the original Agreement dated June 24, 2025. This Amendment does not replace that original Agreement.

We, ROBERT FLINN and MARTIN McALPIN, on behalf of M3 Marketing, LLC, have carefully read this Amendment, consulted with legal counsel of our own choosing, agree with the terms of this Amendment and consent to implementation of the process recited herein.

M3 MARKETING, LLC, an Illinois limited liability company

\_\_\_\_\_  
By: ROBERT FLINN, its Manager

\_\_\_\_\_  
Date

\_\_\_\_\_  
By: MARTIN McALPIN, its Manager

\_\_\_\_\_  
Date

**Amendment to Public Relations and Marketing Agreement**  
**Page 3 of 4**

I, KIMBERLY JONES, on behalf of Maine Township, have carefully read this Amendment, consulted with legal counsel of the TOWNSHIP's choosing, agree with the terms of this Amendment and accept responsibility to implementation of the process recited herein.

MAINE TOWNSHIP, COOK COUNTY, ILLINOIS

\_\_\_\_\_  
By: KIMBERLY JONES, its Township Supervisor

\_\_\_\_\_  
Date

I, ED BEAUVAIS, on behalf of MAINE TOWNSHIP ROAD DISTRICT, have carefully read this Agreement, consulted with legal counsel of the TOWNSHIP's choosing, agree with the terms of this Agreement and accept responsibility to implementation of the process recited herein.

MAINE TOWNSHIP ROAD DISTRICT, COOK COUNTY, ILLINOIS

\_\_\_\_\_  
By: ED BEAUVAIS, its Highway Commissioner

\_\_\_\_\_  
Date

**SCHEDULE B**

## SECOND AMENDMENT TO PUBLIC RELATIONS AND MARKETING AGREEMENT

This second Amendment ("Amendment") to the Public Relations and Marketing Agreement dated June 24, 2025 ("Agreement") is made on \_\_\_\_\_, 2026 by and between MAINE TOWNSHIP of Cook County, Illinois, an Illinois unit of local government, acting through its Authorized Representatives (hereinafter referred to as "TOWNSHIP"), and M3 MARKETING, LLC, a limited liability company organized pursuant to Illinois law, whose principals are ROBERT FLINN and MARTIN McALPIN (hereinafter referred to as "M3"), hereinafter sometimes referred to as "Party" or collectively as "Parties".

On or about June 24, 2025, the Parties entered into the Agreement by which M3 provides certain specified services and TOWNSHIP compensates M3, relying on cooperation and good faith between the Parties. Then, on or about \_\_\_\_\_, 2026, the Parties \_\_\_\_\_ a first amendment to add certain services to the Highway Department. This second Amendment modifies that Agreement further pursuant to Paragraph O.5, by amending Paragraph C, adding a new paragraph I and redesignating the subsequent paragraphs:

*C. Payment for Services and Costs.* Beginning on May 1, 2026, TOWNSHIP shall pay to M3 Three thousand nine hundred fifty dollars (\$3,950.00) per month on or before the last day of each month. TOWNSHIP will own the copyright to any and all written or design work prepared by M3 for TOWNSHIP. In addition to the payments for services, the Parties recognize that M3 will incur certain costs for out-of-pocket expenses and payments to third parties. Schedule A attached to this Agreement outlines the initially anticipated costs, including approximate amounts, which TOWNSHIP agrees to reimburse pursuant to the Local Government Prompt Payment Act (50 ILCS 505/1, et seq), except for such invoices that TOWNSHIP shall pay directly to the invoicing vendor. The Parties shall confirm in writing such payment arrangements to avoid duplication of payments. If M3 subsequently anticipates incurring other costs, to the extent each such cost is less than Fifty dollars even (\$50.00), then M3 is authorized to incur such reimbursable expense and TOWNSHIP shall reimburse M3 in accordance with the Local Government Prompt Payment Act. M3 shall not incur any individual expense in excess of fifty dollars (\$50.00) without prior written approval from the Township.

*I. Physical Newsletter.* M3 shall create a physical newsletter, intended for print and delivery via United States Postal Service, to TOWNSHIP residents four (4) times per calendar year. This newsletter is commonly referred to as the "Mainly News." M3 shall draft content and design the final version for print. TOWNSHIP is responsible for selection of print vendor and all printing, mailing and other transmittal costs. For the remainder of this contract term, M3 and TOWNSHIP agree that June 2026, September 2026, December 2026, and March 2027 are the target months for completion of each edition. Specific dates can be negotiated between M3 and TOWNSHIP. Each edition is estimated at three thousand five hundred (3,500) words or less, and eight (8) or fewer designed pages with dimensions of 8.5x11 inches. Specific word counts, page dimensions, number of pages, and potential adjustments to compensation reflecting such changes, may be further negotiated between M3 and TOWNSHIP.

**Amendment to Public Relations and Marketing Agreement**  
**Page 2 of 3**

In all other respects, the Parties affirm and republish the original Agreement dated June 24, 2025. This Amendment does not replace that original Agreement or the first Amendment to the Agreement.

We, ROBERT FLINN and MARTIN McALPIN, on behalf of M3 Marketing, LLC, have carefully read this Amendment, consulted with legal counsel of our own choosing, agree with the terms of this Amendment and consent to implementation of the process recited herein.

M3 MARKETING, LLC, an Illinois limited liability company

\_\_\_\_\_  
By: ROBERT FLINN, its Manager

\_\_\_\_\_  
Date

\_\_\_\_\_  
By: MARTIN McALPIN, its Manager

\_\_\_\_\_  
Date

**Amendment to Public Relations and Marketing Agreement**  
**Page 3 of 3**

I, KIMBERLY JONES, on behalf of Maine Township, have carefully read this Amendment, consulted with legal counsel of the TOWNSHIP's choosing, agree with the terms of this Amendment and accept responsibility to implementation of the process recited herein.

MAINE TOWNSHIP, COOK COUNTY, ILLINOIS

\_\_\_\_\_  
By: KIMBERLY JONES, its Township Supervisor

\_\_\_\_\_  
Date

**MAINE TOWNSHIP**

**RESOLUTION NO 2026-7**

**A RESOLUTION APPROVING AND MAKING A DETERMINATION ON EXECUTIVE SESSION MEETING MINUTES**

**WHEREAS**, the Board of Trustees of Maine Township has met from time to time in executive session for purposes authorized by the Illinois Open Meetings Act; and

**WHEREAS**, pursuant to 5 ILCS 120/2.06, the Township Board recently conducted a review and approval of executive session meeting minutes; and

**WHEREAS**, the Township Board has determined that certain executive session minutes not yet released should remain confidential, subject to further review and determination as to their appropriateness for release at a future date; and

**WHEREAS**, the Township Board has also determined that verbatim recordings of executive session minutes for meetings that occurred at least 18 months ago and for which minutes have been approved are ready for destruction pursuant to Section 2.06(c) of the Act.

**NOW, THEREFORE, BE IT RESOLVED** by the Supervisor and Board of Trustees of Maine Township, Cook County, Illinois, as follows:

**SECTION 1.** The Township Board of Trustees hereby determines that the following executive session meeting minutes should be approved for content:

<b>APPROVED FOR CONTENT</b>
September 30, 2025
October 28, 2025
November 25, 2025
January 27, 2026
February 24, 2026

**SECTION 2.** The Township Board of Trustees hereby determines that the following approved executive session meeting minutes should now be released to the public:

<b>APPROVED FOR RELEASE TO PUBLIC</b>
October 28, 2025
November 25, 2025
January 27, 2026
February 24, 2026

**SECTION 3.** The Township Board of Trustees hereby determines that the following approved executive session meeting minutes should remain confidential at this time, subject to further review and determination as to their appropriateness for release at a future date:

<b>REMAIN CONFIDENTIAL</b>
October 22, 2019 (1)
May 25, 2021
July 27, 2021
June 27, 2023
July 25, 2023

April 30, 2024
June 25, 2024
October 29, 2024
February 25, 2025
March 25, 2025
April 29, 2025
May 27, 2025
June 24, 2025
July 29, 2025
August 12, 2025
August 26, 2025
September 30, 2025

**SECTION 4.** The Township Board of Trustees hereby determines that verbatim recordings of executive session meetings that occurred at least 18 months ago and for which minutes have been approved are ready for destruction, and hereby directs the Township Clerk to destroy these recordings without further action or approval by the Board.

**SECTION 5.** This Resolution shall take effect immediately upon its passage and approval as provided by law.

**PASSED AND APPROVED** by the Supervisor and Board of Trustees of Maine Township, Illinois, this day of April 28, 2026.

\_\_\_\_\_  
Kimberly Jones, Supervisor, Maine Township

\_\_\_\_\_  
Kelly Horvath, Trustee

\_\_\_\_\_  
Asif Malik, Trustee

\_\_\_\_\_  
James Maher, Trustee

\_\_\_\_\_  
Elizabeth Lynch, Trustee

ATTEST:

\_\_\_\_\_  
Peter Gialamas, Clerk, Maine Township



4/28/26

---

**TO:** Elected Officials

**FROM:** Victoria Rizzo, Administrator

---

**SUBJECT:** Engagement Letter with Evans Marshall and Pease

---

- Discussion and Possible Vote to Approve Engagement Letter with Evans, Marshall & Pease, P.C.

This agenda item authorizes the Township to enter an engagement letter with an accounting firm to provide professional financial services. The engagement letter outlines the scope of services, responsibilities of both parties and rates. These services include monthly and annual services and audit support. Approval ensures the Township maintains compliance with financial reporting requirements and continues to receive expert guidance on fiscal matters.



SINCE 1917

## EVANS, MARSHALL & PEASE, P.C.

CERTIFIED PUBLIC ACCOUNTANTS  
AND CONSULTANTS

1875 Hicks Road  
Rolling Meadows, Illinois 60008

Telephone (847) 221-5700  
Facsimile (847) 221-5701

April 20, 2026

Board of Trustees and Management  
Maine Township  
1700 Ballard Road  
Park Ridge, IL 60068

We are pleased to confirm our understanding of the nature and limitations of the services we are to provide Maine Township from March 1, 2026 to February 28, 2027. We will perform a consulting engagement to assist you with your accounting functions on areas and other items as follows:

We will provide the following accounting services as follows:

### Monthly Services

- Prepare and submit IMRF reports and process required payments through the IMRF Employer Website (employer.imrf.org) for the Town Fund, General Assistance (GA) Fund, and Road & Bridge (RB) Fund.
- Record and reconcile Mainstreamers activity to the Quicken register.
- Allocate and record postage expenses in SAGE.
- Record IMRF journal entries in SAGE for all three funds based on monthly IMRF reporting.
- Prepare and complete monthly bank reconciliations for all township accounts, with electronic copies securely maintained on the EMP server:
  - Town Fund – 8 accounts
  - GA Fund – 3 accounts
  - RB Fund – 2 accounts
- Identify and correct deposit and check discrepancies identified during the bank reconciliation process (e.g., posting or clearing errors).
  - Corrections are made either upon receipt of information from township staff or as identified by EMP during the reconciliation process and subsequently recorded in SAGE.
- Prepare and review monthly income statements for all three funds.
- Prepare the Road Fund monthly report for the Chief Deputy Clerk, reconciling monthly activity to the balance sheet, including all checks issued, electronic payments, and deposits.

### Annual Services

- Prepare the Supervisor's Annual Report.
- Prepare the Treasurer's Annual Report.
- Assist with estimating beginning fund balances for budget preparation.
- Enter the Board-approved agency listing into SAGE.
- Enter the adopted budget into SAGE for all three funds.
- Prepare income statements aligned to the newly adopted budget for all three funds in SAGE.
- Close and open fiscal periods in SAGE for all three funds.

- Prepare, electronically file, and coordinate mailing of Form 1099-NEC for all three funds (mailing performed through EMP's third-party service provider).
- Write off outstanding checks in accordance with Township policy.
- Provide assistance with Township, as needed.

**Audit Support**

- Provide electronic bank reconciliations to township staff for audit purposes.
- Assist township staff as needed during the audit process by responding to auditor inquiries related to reconciliations and financial activity.

Our procedures will involve working with your SAGE file, reconciliations, Excel spreadsheets and other reports and software as necessary. In addition, we are available for consultation on various matters including your annual tax levy and budget and appropriation ordinance. We will generally work with your systems and documents at our office remotely through a secure server.

You are responsible for management decisions and functions, and for designating a competent employee to oversee the services we provided. You are responsible for evaluating the adequacy and results of the services performed and accepting responsibility for such services. You are responsible for establishing and maintaining internal controls, including monitoring ongoing activities.

Although accounting errors may be discovered and corrected, our consulting engagement cannot be relied upon to disclose all errors or fraud and irregularities that may exist.

Christopher Scalet, CPA is the engagement partner and is responsible for supervising the engagement.

Our charges for these services will be at our standard hourly rates of between \$200 (staff) and \$275 (partner) per hour.

We sincerely appreciate the opportunity to offer our expertise and experience to Maine Township and believe this letter accurately summarizes the significant terms of our engagement. If you have any questions, please contact us. If the arrangements, as outlined above, meet with your approval, we ask that you please sign below and return this to us.

Very truly yours,



Christopher Scalet, CPA

Evans, Marshall & Pease, P.C.  
 Certified Public Accountants

**RESPONSE:**

This letter correctly sets forth the understanding of Maine Township:

By: \_\_\_\_\_

Title: \_\_\_\_\_

Date: \_\_\_\_\_

## MAINE TOWNSHIP CLERK'S SERVICES MONTHLY SUMMARY FOR THE YEAR 2026

SERVICES	JANUARY	FEBRUARY	MARCH	APRIL	MAY	JUNE	JULY	AUGUST	SEPTEMBER	OCTOBER	NOVEMBER	DECEMBER	TOTAL
FOIA Req.	4 4	4 5	1 3	0 16	0 2	0 6	0 4	0 5	0 6	0 5	0 8	0 9	<b>9</b> 73
Garbage Stickers	33 39	0 29	86 30	0 144	0 155	0 113	0 133	0 150	0 77	0 147	0 148	0 59	<b>119</b> 1224
Handicap Placards	4 0	0 0	2 1	0 3	0 3	0 2	0 4	0 3	0 1	0 0	0 2	0 3	<b>6</b> 22
Hunting & Fishing Lic.	1 0	0 0	4 3	0 15	0 7	0 5	0 8	0 5	0 11	0 16	0 2	0 1	<b>5</b> 73
License Plate Stckr	11 13	13 8	16 15	0 15	0 25	0 29	0 25	0 25	0 22	0 20	0 15	0 17	<b>40</b> 229
Maineline Coupons	50 6	40 9	0 10	0 7	0 0	0 0	0 0	0 46	0 0	0 35	0 40	0 20	<b>90</b> 173
Neighbor/Neighbor/	251 240	5 250	5 0	0 2	0 0	0 0	0 0	0 372	0 3	0 0	0 0	0 1	<b>261</b> 868
Notary Public	25 17	11 19	27 37	0 22	0 25	0 36	0 66	0 94	0 23	0 28	0 20	0 16	<b>63</b> 403
Passport Application	167 169	154 168	166 181	0 167	0 164	0 141	0 159	0 136	0 114	0 159	0 111	0 113	<b>487</b> 1782
Passport DS-82 Review	29 0	34 0	43 0	0 36	0 15	0 57	0 31	0 23	0 20	0 26	0 10	0 35	<b>106</b> 253
Phone Calls	386 0	344 0	331 0	0 226	0 232	0 309	0 334	0 307	0 343	0 259	0 219	0 245	<b>1061</b> 2474
RTA Passes	8 7	8 16	18 27	0 16	0 22	0 25	0 32	0 22	0 16	0 18	0 25	0 13	<b>34</b> 239
Translation Services	24 0	19 0	56 0	0 18	0 7	0 45	0 44	0 31	0 26	0 22	0 20	0 35	<b>99</b> 248
In Person Visits	214 0	224 0	152 0	0 163	0 117	0 191	0 233	0 198	0 210	0 185	0 139	0 188	<b>590</b> 1624
Voter Regist.	0 0	1 0	0 0	0 1	0 0	0 0	0 1	0 1	0 0	0 0	0 2	0 0	<b>1</b> 5
<b>TOTAL</b>	<b>1207</b> 492	<b>857</b> 506	<b>907</b> 307	<b>0</b> 852	<b>0</b> 779	<b>0</b> 959	<b>0</b> 1,074	<b>0</b> 1,418	<b>0</b> 872	<b>0</b> 920	<b>0</b> 761	<b>0</b> 768	<b>2,971</b> 9,708

\* The numbers in the second row indicate services provided in the year 2025

\* Current Month Fishing License Commission **\$3.00**

\* Current Month Passports Processing Fee **\$3,454.00**

\* Current Month License Plate Sticker Commission **\$76.50**

**YTD \$3.50**

**YTD \$12,405.00**

**YTD \$188.70**

# Maine Township Assessor's Office 2026 Monthly Summary of Taxpayer Services

	Jan	Feb	March	April	May	June	July	August	Sept	Oct	Nov	Dec	Total
Calls	153	322	1075	225									1775
Visits	140	300	2752	1008									4200
Permits	217	235	56	0									508
Welcome letters	251	0	0	0									251
Cert. of Errors	126	42	65	125									358
HO	0	0	23	0									23
Senior	0	0	56	0									56
Freeze	0	0	49	0									49
Disability	0	0	5	0									5
Vets	0	0	5	0									5
Waivers	1	0	0	0									1
Treasurer Apply for Overpayment	4	4	6	0									14
Name/Address	17	0	13	15									45
Appeals	0	0	0	0									0
Prop. Loc	2	0	5	0									7
Exempt Inq.	0	1	0	0									1
Assessment Inq.	2	2	0	0									4
FOI	1	2	0	0									3
Treasurer Tax Deferral	2	6	0	0									8
2026 C/E \$ Saved Taxpayers	0	\$87,668.65		\$ 109,557.41	\$ -		\$ -	\$ -	\$ -	\$ -		\$ -	\$ 197,226.06
2025 C/ E \$ Saved Taxpayers (Carryover)													\$975,343.79

z: Assessor/2026 Yearly Summary of Taxpayer Services\_ by month

Updated 4/20/2026

## GENERAL ASSISTANCE DEPARTMENT REPORT

MARCH 2026

BY: LUZ MENESES

March marked a highly active and productive month for General Assistance department.

As we entered the spring season, our team continued expand access to critical services while responding to increased community needs.

### **GENERAL ASSISTANCE AND EMERGENCY ASSISTANCE PROGRAMS**

4 individuals received financial assistance (GA); ongoing monitoring their disability (SSDI) and Supplemental Security Income (SSI) claims. 1 case is pending documents to be submitted by client and 1 case was closed due that client moved to a different area.

4 Rental Assistance applications are pending required documents, including Five Day Notice.

3 Rental Assistance cases were closed because clients failed to provide the missing documents within the 30 days following their interview.

### **ADVOCACY HEALTH CARE**

Case managers completed 6 Public Aid applications and 3 appeals were filed and submitted on behalf of clients who disagreed with prior determination.

This March, staff helped 3 clients in obtaining Access To Care coverage, as they didn't qualify for Medicaid assistance.

12 Coast To Coast cards were provided, which can assist in reducing expenses related to prescriptions, supplies, and other associated costs.

### **SERVICES FOR ADULTS**

This month 2 Medicare Extra Help Drug Assistance were completed and submitted.

9 Seniors received assistance obtaining a 75% discount on their License Plate Sticker and a Free Transportation card through the Benefit Access program.

13 eligible applicants were assisted in completing Lifeline applications for discounted phone or internet services.

### **PRACTICAL SUPPORT**

A total of 6 clients received application and or information from our office regarding our Mainlines program as a great option to meet transportation needs.

Our staff distributed section 8 lists and other housing related materials to 5 clients who are in need of housing assistance.

During March, a total **102** Ceda applications were completed for utility assistance, PIPP Recertification and Weatherization. We also offer information regarding additional assistance provided by the utility companies and encourage clients to explore their available options.

#### **NEIGHBORHOOD AID**

**61** individuals received assistance related to Unemployment Benefits, free tax filing resources, WIC, meals, Legal Aid, transportation options, food pantry referrals, etc.

#### **STAFF UPDATES:**

We are pleased to Welcome Vivian Kalish, our new Office Manager, who joined the General Assistance team on March 2, 2026. She has quickly adapted to her role and has demonstrated strong organizational skills, professionalism and the ability to effectively manage a high volume of phone calls, emails and in person visits.

Vivian also responsible for managing the schedule of rides in the Shuttle bus, returning phone calls and cancelling or making changes to rides.

Additionally, she is tasked with maintaining communication with the two drivers and ensuring that they have a weekly schedule for the following week.

During March she received approximately 242 calls and office visits from individuals inquiring about our services and programs and around 23 calls per day regarding the Shuttle bus.

Lastly, the Senior Expo on March 13, 2026 was a productive event that fostered community engagement and facilitated partnerships with local agencies.

MAINE TOWNSHIP  
GENERAL ASSISTANCE PROGRAM  
EMERGENCY RENT PROGRAM  
AND  
OTHER SOCIAL SERVICES

**Statistic Report for MARCH 2026**  
By Luz Meneses

**GENERAL ASSISTANCE**

**Number of Clients**

Pending SSDI/SSI	04
Searching for Work	0
Pending	01
Denied – Incomplete applications, missing documents/non-contact	0
Over income/SSA Benefits	0
Other (voluntarily closed/moved out of Township)	01
<b>Total</b>	<b>06</b>

**EMERGENCY RENT PROGRAM**

**Number of Clients**

Pending	04
Approved	0
Denied – incomplete applications, missing documents/non-contact	03
Other (voluntarily closed/moved out of Township)	0
<b>Total</b>	<b>07</b>

**ADDITIONAL SOCIAL SERVICES**

**ADVOCACY HEALTH CARE**

Public Aid programs	09
Access to Care	03
Coast 2 Coast Free Prescription Discount Card	12
<b>Total</b>	<b>24</b>

**SERVICES FOR ADULTS**

Medicare Service Programs/QMB SHIP	02
Benefit Access	09
Lifeline Program (phone/internet discount)	13
Veteran Referral Assistance	0
<b>Total</b>	<b>24</b>

MAINE TOWNSHIP  
GENERAL ASSISTANCE PROGRAM  
EMERGENCY RENT PROGRAM  
AND  
OTHER SOCIAL SERVICES

**Statistic Report for MARCH 2026**  
By Luz Meneses

**PRACTICAL SUPPORT**

MaineLines Taxicab program/Transportation Assistance	06
Subsidized Housing (Section 8)	05
CEDA Programs: DVP, PIPP, RA, Furnace, STW, Weatherization	102
<b>Total</b>	<b>113</b>

**NEIGHBORHOOD AID**

Food Banks/MTS FP:	
Free Taxes	30
Caregivers	05
Meals	07
Legal Aid	06
Child Care	02
Job Fair/Training/Employment Referrals	01
Shelters/Housing	10
<b>Total</b>	<b>61</b>

**Maine Township Code  
Enforcement Office**

**To:** Elected Officials  
**From:** Nader Ghazaleh, Code Enforcement Officer  
**CC:** Victoria Rizzo, Administrator  
**Date:** 4/18/2026  
**Re:** Monthly Report

---

Construction season has once again arrived here at Maine Township. This time of the season has been very steady with permit questions streaming into my office. Residents are planning ahead to start projects now that spring is here. This past month has only brought one contractor that did not get the correct permits for concrete work. I issued a fine of to that contractor which has been paid in full. I continue to work with Cook County Building & Zoning Inspectors to learn their ever-changing ordinance requirements and pass not only their requirements to our residents but also ours. I have found myself receiving many compliments in regards to residents appreciating they do not have to make numerous phone calls in regards to their permit questions. Has been a busy month writing deficiencies. Sumac is an ongoing challenge with fly dumping furniture, garbage, tires etc. working with Flood Bros to get it cleaned up. I believe transit residents are a big problem, being not familiar with ordinances. Have given out three property maintenance deficiency's regarding, painting, driveway replacement, removal of an illegal pigeon coop, hopefully for compliance.

I have tickets issued for commercial taxis vehicles on our streets. Many residents have contacted me thanking me for removing these vehicles from the community. These two ordinances alone have been very time consuming for me, but the efforts have paid off well. Tuesdays and Thursdays are always busy days, for ticket and tow areas. Most residents are aware of signage and comply, while other is repeating offenders. I'm excited to announce hard work pays off. Have reached compliance 8853 Robin Drive regarding fallen tree. Working closely with Aqua to ensure residents are receiving assistance regarding recent flooding in the area.

March Deficiency's 15

March Citations 17

- 1- No construction permits
- 3- Commercial vehicles
- 1- Abandoned vehicle
- 12- No parking tow zone

# MAINE TOWNSHIP FOOD PANTRY

## APRIL MONTHLY REPORT

(March 1, 2026 thru March 31, 2026)





♦ Kimberly Jones – Maine Township Supervisor ♦ Michael Pitzafferro – Director Food Pantry

### Operational Updates



March saw several changes in the food pantry including the following:

- Finalized the new Website for the Maine Township Foundation Food Pantry at-  
Mainetownshipfoundation.org
- Received a Rivers Casino Restrictive Grant for \$10,000
- Received a Door Dash Grant for \$5,000.00





### Services

	<b>Household Visits to Maine Township Food Pantry</b>	1,173
	<b>Individuals served through the Food Pantry</b>	2,425
	<b>New Households registered to Food Pantry</b> (79 New Signup / 9 transfers from other pantries)	88
	<b>School District 63 - Weekend To-Go-Bags</b>	172
	<b>General Assistance Emergency Food Bags</b>	100 Bags / Month

### Volunteers

 SHIFTS / HOURS	<b>Volunteer Shifts / Hours</b>	377 shifts /985.43 hours
	<b>Active Volunteers</b>	70

## Donations

	<b>Weekly Deliveries</b>	50,634 pounds of food received in March
	<b>Pickups on Tuesday, Wednesday, Thursday, Friday</b>	1500 pounds of bread and pastries
	<b>Pickups on Monday, Wednesday, Friday</b>	6,770 pounds of Bakery, Dairy and Grocery Items
	<b>Daily Resident Drop-offs in the Maine Township Lobby</b>	3864 pounds of grocery and personal care items
	<b>Cash or Check Donations</b>	\$16,779.90

# MAINESTAY YOUTH & FAMILY SERVICES

## APRIL 2026 BOARD REPORT

### RICHARD LYON, DIRECTOR

For over 50 years, [MaineStay](#) has faithfully served the Maine Township community with the mission of building healthier families by providing strength-based counseling, prevention initiatives, and comprehensive youth and educational programs that support growth, resilience, and well-being.

#### MAINE TOWNSHIP AGENCY DAY – MAY 1

Our 43<sup>rd</sup> annual Maine Township Agency Day will be held on Friday, May 1 at Manzo's Banquets in Des Plaines from 9 am – 1 pm. This event provides a great opportunity for local organizations to learn about services in the Maine Township community and is open to employees from social service agencies, non-profits, schools, churches, hospitals, and units of government. There will be multiple opportunities for networking among agencies and organizations. Our speaker this year will be Paula R. Jenkins, a nationally recognized leadership speaker whose presentation is entitled *You're Either Connecting or Repelling — Which One Are You? The Power of Authentic Leadership & Communication in Nonprofit Spaces*. At the conclusion of the workshop, organizations will be able to share their mission and services with those in attendance in order to increase awareness of available local resources and better serve our residents. Gateway Foundation, Recovery Centers of America, Rosecrance Behavioral Health, Trinity Services, Inc., Jeffrey A. Rabin & Associates, Ltd., and Des Plaines Community Foundation are our sponsors for this year's event. Admission is free for all Maine Township employees and elected officials. Please contact Iain Parker to sign up.

#### FEATURED STORY OF THE MONTH

Summer Zumbrock recently facilitated two Magical Moments Play Therapy Group programs, a Theraplay-based intervention designed to support emotional regulation, strengthen social skills, and foster positive peer and adult connections. One group served children ages 3½ to 5½ and was co-facilitated with Intern Therapist Allison Zanolli, while the second group served children ages 8 to 10 and was co-facilitated with Intern Therapist Lauren DeHahn.

The older group consisted entirely of neurodivergent children and provided a highly engaging and active space for participants to build meaningful connections. Over the course of the group, children demonstrated increased ability to connect with peers and facilitators, with several participants forming friendships that extended beyond the group, including exchanging contact information and planning playdates and online gaming together. A key outcome for this group was the development of safe, positive peer relationships and a sense of belonging.

In the younger group, Summer Zumbrock and Allison Zanolli observed significant individual and group-wide growth. One participant initially presented as minimally verbal and had difficulty engaging in group activities; by the end of the group, the child was actively participating, singing songs, and eagerly engaging in nurturing check-in routines, including sharing and seeking care through playful activities such as the "magic cotton ball." Another participant initially struggled with transitions between activities, which were highly dysregulating; through consistent support and structured play-based interventions, the child demonstrated increased ability to tolerate transitions and move between activities with greater regulation.

Throughout both groups, therapeutic goals were addressed through developmentally appropriate, play-based experiences that allowed children to build skills in a safe and engaging environment. For example, games such as "red light, green light" were used to support turn-taking, delayed gratification, and flexible responding, while consistent routines such as hello songs and snack songs helped promote regulation, predictability, and a sense of safety within the group. These interventions allowed children to engage in therapeutic work in a way that felt natural and enjoyable, rather than directive or problem-focused.

Caregivers reported positive outcomes across both groups, including improved social engagement and emotional regulation, and expressed strong interest in continued participation due to the meaningful connections their children developed. This group highlights the effectiveness of Theraplay-based play therapy interventions in supporting both neurodivergent and neurotypical children in building connection, regulation, and confidence through shared play experiences.

## COUNSELING SERVICES

We had 3 new counseling intakes completed during March and are working with a total of 82 cases in our affordable, strength-based counseling program that is available to residents in the office, via telehealth, and at three local schools. MaineStay is honored to have provided our residents with local and convenient access to mental health services for over 50 years.

## SUMMER CAMP

We are still accepting applications for our Adventure Maine Township Summer Camp program for at-risk youth, ages 8-13, who qualify based on family income. The first camp session from June 15-25 is already full, and the second session from July 13-23 has three spaces remaining. This camp provides a supportive and structured environment where children can improve their social skills while being exposed to new activities they may not otherwise be able to experience.

## PROGRAM SCHEDULE

Below is a list of some of our upcoming programs.

- **[Cooking Class - Superhero Superfoods](#) – May 6 | 5-6 pm | 3 weeks | ages 8-17**  
In this class, our young chefs will whip up superhero-worthy dishes packed with delicious, nutritious superfoods! From vitamins to antioxidants to protein powerhouses, kids will discover ingredients that fuel their bodies for peak performance. Through hands-on cooking, they'll learn kitchen safety and fundamental cooking techniques. Every class is a tasty adventure, inspiring kids to create healthy meals that make them feel like real-life superheroes!
- **[Mother's Day Paint and Snack](#) – May 11 | 6-7:30 pm | ages 5+**  
Join us for a delightful evening of creativity and fun to celebrate women everywhere.
- **[Family Fun Nights](#) – May 14 | 6-7:30 pm | families with children ages 5+**  
This drop-in event is designed to help families connect by choosing from activities that suit their interests—from playing games and engaging in arts and crafts, to enjoying a family-friendly movie.
- **[Magical Moments: Play Therapy Group](#) – June 2 | 5:15-6 pm | 8 weeks | ages 5.5-8.5**  
This Theraplay-based group is designed to nurture emotional bonds, build confidence, and strengthen social skills in children.
- **[Magical Moments: Play Therapy Group](#) – June 3 | 4:45-5:30 pm | 8 weeks | ages 8.5-11.5**  
This Theraplay-based group is designed to nurture emotional bonds, build confidence, and strengthen social skills in children.
- **[Magical Moments: Play Therapy Group](#) – June 9 | 3:15-3:45 pm | 8 weeks | ages 3.5-5.5**  
This Theraplay-based group is designed to nurture emotional bonds, build confidence, and strengthen social skills in children.
- **[Summer Camp](#) – June 15 (session 1) & July 13 (session 2) | 2 weeks | ages 8-13**  
This program provides a supportive and structured environment where children can improve their social skills while being exposed to new activities they may not otherwise be able to experience.
- **[Mentoring](#) – every other Tuesday | 6-7:30 pm | ages 8-12**  
Our Big Brothers Big Sisters Mentoring Program—now in its 10th year—meets in a structured group setting and helps children enhance their social skills, confidence, and academic success.
- **[Future Leaders](#) – every other Thursday | 3-4:30 pm | grades 6-8**  
This school-based SEL program allows middle school students to benefit from positive peer mentoring relationships with older high school students.



## MAINSTREAMERS HIGHLIGHTS

March 2026

Marie Dachniwsky, Director

In March, the MaineStreamers offered four exciting day trips for our members: *Union League Club of Chicago*, *Dear Evan Hansen -Musical*, *The Play That Goes Wrong* and *American Place Casino*. We continued to host our regular monthly programs - Bingo, Movie, Day at the Races, Fitness Classes, Informative Program, St. Patrick's Day Luncheon, Twilight Dining and a Health Program. Throughout the month a combined total of 689 members (some duplicated) were able to enjoy our MaineStreamer activities.

Some of the featured events and trips for the month of March were:

**St. Patrick's Day Luncheon** – What a wonderful way to spend a perfect afternoon! More than 170 members, along with Supervisor Jones and many dressed in green, gathered to enjoy a delicious corned beef and cabbage meal with friends while celebrating St. Patrick's Day. After lunch, everyone was tapping their toes and singing along as The Chicago Irish Band performed favorite Irish classics and hits from across the decades, bringing a lively slice of Ireland for all to enjoy. The festive atmosphere, filled with music, laughter, great company, and even some dancing of the Irish jig, made it a truly memorable celebration for everyone. It was a joyful afternoon that left everyone smiling and already looking forward to next year's celebration.



**Union League Club of Chicago** – We began our day with a guided tour of one of the Midwest's largest private art collections at the Union League Club of Chicago—widely recognized as one of the top clubs in the world. The Club's impressive collection features more than 700 works of art, showcasing a rich diversity of styles, regions, and time periods. With a strong emphasis on American art—especially 20th-century Midwestern pieces—the collection offers a unique and inspiring cultural experience. Following the tour, members enjoyed a delicious lunch buffet in the Club's elegant private Heritage Room. It was prepared by talented chefs dedicated to excellence. The meal featured high-quality ingredients and reflected the exceptional standards of this renowned private club.



***Dear Evan Hansen*** - Members had a wonderful day enjoying the heartfelt and powerful *Dear Evan Hansen*, at the Paramount Theatre in Aurora. It is a six-time Tony Award winner. The story's message of belonging, acceptance, and being seen truly resonated with everyone. Before the show, the group shared a delicious meal at Vai's Italian Kitchen, one of their favorite spots, making it a meaningful and memorable outing.

***The Play That Goes Wrong, Metropolis Performing Arts Centre*** - Members enjoyed a fun and laughter-filled day at *The Play That Goes Wrong*, an Olivier Award-winning comedy that blends Monty Python-style humor with a Sherlock Holmes-inspired whodunit, as a bumbling troupe's attempt at a 1920s murder mystery hilariously unraveled into complete chaos—providing the perfect lighthearted escape for everyone. Prior to the show members enjoyed a delicious lunch at Trezeros.

***American Place Casino, Waukegan*** – Members enjoyed trying their luck at American Place Casino, spending the day exploring a variety of video and slot machines along with exciting table games. Participants also took advantage of special incentives, including free slot play and dining discounts. As the first time the MaineStreamers visited this local casino, it made for a fun and memorable new experience for all.

***Fitness Classes*** – We offer a variety of weekly Fitness classes to all levels of members.

-***Senior Aerobics*** - Held on Mondays and Wednesdays, at the Feldman Center, Niles. This class increases your strength, balance, flexibility, and coordination in sitting and/or standing position.

-***Zumba Gold*** - Held on Thursdays, at the Feldman Center, Niles. Zumba Gold fuses Latin rhythms and Easy to follow moves for a great fitness program in a Party-like atmosphere.

-***Yoga*** - This class is taught at a relaxed pace, integrating breath work with deliberate muscle elongation, toning, and balance. It is held at Maine Township, in the Board Room on Monday Evenings. The instructor Diane McDonald, has been teaching this class for the MaineStreamers for over 30 years.

-***Chair Yoga*** – In this class members use a chair and seated poses to begin and end each class. Standing poses are used to build strength in your legs and core so as we age we maintain movement, balance, and flexibility.

***Twilight Dining*** – We hosted our Twilight Dining program at Peggy Kinnane's Irish Restaurant & Pub in Arlington Heights. Since St. Patrick's Day is celebrated throughout the month, we continued the festivities at this lively Irish pub. Over 45 members gathered for an evening filled with great food, laughter, and engaging conversation. Members selected their entrées in advance, choosing from traditional favorites like Fish N' Chips, Corned Beef and Cabbage, Shepherd's Pie, and Corned Beef Colcannon. It was a fun and welcoming night for all, giving everyone a chance to connect, meet new people, and enjoy a festive dinner out with friends.

MAINESTREAMERS 2026 STATISTICAL REPORT - March 2026

	NO. OF PARTICIPANTS	YEAR TO DATE	INCOME	EXPENSES	TOTAL
<b>RECREATIONAL PROGRAMS</b>					
Bingo (Monthly)	54	149	\$332.00	\$154.95	\$177.05
Day at the Races (Monthly)	44	129	\$0.00	\$31.96	(\$31.96)
Movie of the Month (Monthly)	35	113	\$74.00	\$0.00	\$74.00
Twilight Dining Outing (Alternating Months)	42	82	\$1,684.00	\$1,660.68	\$23.32
Craft Classes -		27			\$0.00
Floral Design					\$0.00
<b>HEALTH/INFORMATIVE</b>					
Taking the Ache Out of Arthritis	46	397	\$12.00	\$325.00	(\$313.00)
Dead Air: the Night Orson Wells Terrified America	93				\$0.00
					\$0.00
<b>FITNESS CLASSES</b>					
Senior Aerobics (8 week sessions)		28			\$0.00
Yoga (8 Week Sessions)		7			\$0.00
Zumba Gold		12			\$0.00
Chair Yoga		20			\$0.00
<b>CLASSES/PROGRAMS</b>					
Computer Class (Alternating Months)	13	32	\$130.00	\$200.00	(\$70.00)
Defensive Driving Course (Held Quarterly)		8			\$0.00
<b>LUNCHEON</b>					
	162	312	\$5,531.00	\$6,244.61	(\$713.61)
<b>SPECIAL EVENTS</b>					
		150			\$0.00
					\$0.00
<b>DAY TRIPS</b>					
	200	489	\$14,863.00	\$15,842.99	(\$979.99)
<b>LONG DISTANCE TRIPS</b>					
		4			\$0.00
<b>SENIOR MAILING (Bi-Monthly)</b>					
<b>ADVISORY COUNCIL MEETING (Held Quarterly)</b>					
<b>TOTAL</b>	689	1975	\$22,626.00	\$24,460.19	(\$1,834.19)
Misc. Expenditures				\$49.52	(\$49.52)
<b>Additional Expenses (see below)</b>				\$537.93	(\$537.93)
					(\$2,421.64)

ADDITIONAL EXPENSES (STARTED FISCAL YR. 2023)	EXPENSES	TOTAL year to date
Monthly Postage	\$290.79	\$1,555.45
Printing & Publishing (MaineStreamer Newsletter)	\$0.00	\$1,011.00
Forte fees	\$247.14	\$1,755.86

**Maine Township**  
**MaineStreamers Account Income/Expenses**  
**March 2026**

<b>Beginning Balance 3/1/2026</b>	<u><b>\$115,303.67</b></u>
<b>Income</b>	
Total amount of checks deposited (e.g., member event fees, vendor refunds)	\$9,965.84
<b>Expenses</b>	
Total Subtractions (e.g., venues, bus transportation)	<u><b>\$29,820.57</b></u>
<b>Ending Balance 3/31/2026</b>	<u><b>\$95,448.94</b></u>

Ending Bank Balance **\$95,448.94**

**\* Please Note**

This is an account separate from the General Town Fund



## Board Report for April, 2026

Marty Cook

### Friday Night Recovery Meetings at Maine Township Attendance:

March 27, 2026	48 Participants
April 3, 2026	52 Participants
April 10, 2026	70 Participants
April 17, 2026	65 Participants

### Community Outreach/Events:

April is Alcohol Awareness month with in mind Recovery Connection holding special events all month. On Saturday, April 18 we hosted an evening with TV star and standup comedian Billy Gardell - most famous for his role on Mike & Molly. Billy is a friend of recovery and hosted our group backstage for a post-show meet and greet where he took pictures and shared how his success in show business would not have been possible without his sobriety.



Recovery Connection realizes drug and alcohol addiction harms the entire family, when our loved ones recover, so too does the family. On Sunday, April 19 Recovery Connection hosted our annual Family and Volunteer Appreciation outing to the Chicago Wolves game. Our Friday night meetings and family intervention services would not be possible without volunteers who are willing to share their recovery stories in front of 50 - 75 people every week. This year we hosted over 100 people for this family friendly event. The amount of gratitude from children and parents to Maine Township for this event was truly overwhelming.



On April 10th we welcomed local resident and author, Eddie Arena to talk about his book, "Ice Water Please " That detailed his very local story of coming to grips with his alcoholism and now helping others to find sobriety.



Marty Cook was invited to speak to parents and staff about What should you do if you find your child using drugs and or alcohol. Besides Recovery Connection, Cook also highlighted our Mainstay programs and other local resources.

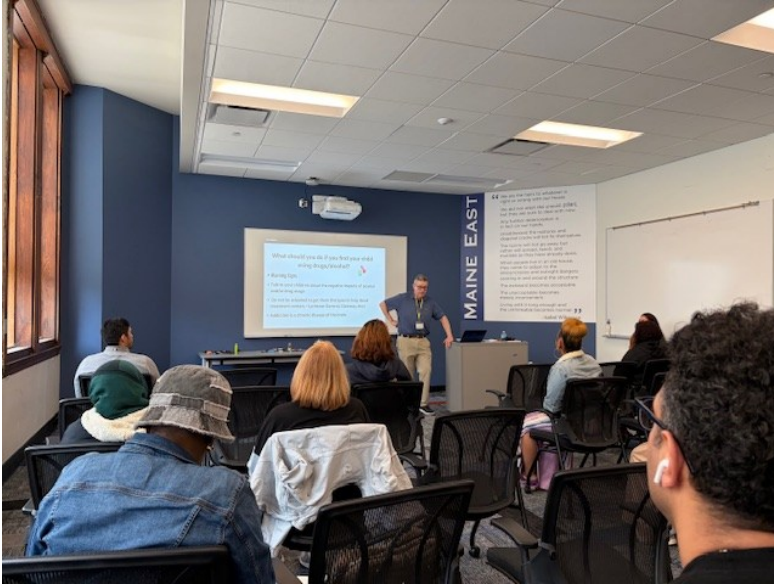

A special note of thanks to Supervisor Kim Jones, Administrator Vicky Rizzo and driver Jim Doherty who went above and beyond to assist a recovery connection participant- and his physically challenged son -make it to our family outing at the Wolves game on Sunday, April 19.

Erick's 13-year-old son Max has been confined to a wheelchair his entire life. The Saturday before the game, Erick realized the para service needed to transport his son was not going to materialize, in a last-ditch effort to make sure Max could attend the game, he reached out to Marty to see if Maine Township could help. The Wolves hockey game was always a big thrill for Max who was looking forward to attending. On a late Saturday afternoon Kim and Vickie got involved and reached out to Jim who agreed to come in on Sunday to pick up Max in our accessible bus and to get them to and from the game.

Erick and Max had a great time, and offered their heartfelt thanks to Jim, Kim and Vicki.





- Monday night sober yoga had 12 participants.
- Recovery Connection Saturday Sober Pickleball league averaging 20 players per week
- Recovery Connection Tuesday and Thursday Sober from Nicotine zoom group, 15 per session.
- Began a sober fitness class with 6 participants

**Social Media Communications:**

**E- Newsletter**

- 4 e-newsletters sent to 610 participants and local health agencies.
- 300 weekly opens (approximately 50% of participants).

**Recovery Connection Facebook Page:**

- 6 posts per month.
- 302 Members.

# FOIA

Jessica Guzman

**From:** noreply@revize.com  
**Sent:** Sunday, April 5, 2026 9:49 PM - Received after hours  
**To:** Eva Magnowski  
**Cc:** Jessica Guzman  
**Subject:** [External] FOIA Request Form

**External Sender** - From: (noreply@revize.com)

[Learn More](#)

This message came from outside your organization.

First\_Name = [REDACTED]

Last\_Name = [REDACTED]

Address = [REDACTED]

Email = [REDACTED]

Phone = [REDACTED]

Requested\_Records = April 6, 2026

Subject: FOIA Request – Maine West High School Discipline Data

Dear FOIA Officer,

Pursuant to the Illinois Freedom of Information Act, I am requesting de-identified, aggregate data for Maine West High School for the 2025–2026 school year (to date), 2024–2025, and 2023–2024 school years related to student disciplinary incidents involving the sale and/or distribution of illegal substances.

Specifically, I am requesting:

1. The total number of incidents per school year
2. The total number of unique students involved per school year
3. The number of unique students involved, disaggregated by grade level for each school year
4. The number of incidents, disaggregated by grade level for each school year
5. A breakdown of disciplinary actions taken for these incidents, including but not limited to suspension, recommendation for expulsion, alternative placement, and any other disciplinary outcomes applied (e.g., restorative practices, probation, counseling, or other interventions), if maintained in existing records
6. The number of students recommended for expulsion for these incidents, disaggregated by school year and grade level
7. The number of students recommended for alternative placement in lieu of expulsion, disaggregated by school year and grade level
8. The number of students involved in incidents of the sale and/or distribution of illegal substances, categorized as first-time offenses or repeated offenses within the same school year, disaggregated by school year and grade level (reported as aggregate counts only), if maintained in existing records.

Additionally, I am requesting the following disaggregated counts to better understand disciplinary outcomes:

9. The number of students identified as first-time offenders who were recommended for expulsion, disaggregated by school year and grade level

10. The number of students identified as first-time offenders who were recommended for alternative placement in lieu of expulsion, disaggregated by school year and grade level

11. The number of students with multiple incidents who were recommended for expulsion, disaggregated by school year and grade level

12. The number of students with multiple incidents who were recommended for alternative placement in lieu of expulsion, disaggregated by school year and grade level

13. A breakdown of incidents by general infraction category (e.g., sale, distribution, possession with intent), if such distinctions are maintained in existing records  
Additionally, I am requesting copies of the following records:

1. The official District 207 and Maine West disciplinary handbooks and policies in effect for the requested years.
2. Any internal guidelines, rubrics, or "matrices" used by administrators to determine the progression of discipline from suspension to expulsion.
3. Procedures or criteria used to determine eligibility for "alternative placement" at facilities such as North Cook Young Adult Academy.

If any portion of this request is deemed exempt, please provide the non-exempt portions and a written explanation for any redactions, citing the specific FOIA exemption relied upon.

This request is intended to better understand trends in disciplinary practices and ensure equitable and consistent implementation of policies.

Thank you for your time and assistance.



Inspect\_or\_Copy = Copy  
Commercial\_Purpose = No  
How\_Receive = In Person  
Client IP = 172.58.165.24

**Eva Magnowski**

---

**From:** noreply@revize.com  
**Sent:** Tuesday, April 7, 2026 8:51 AM  
**To:** Eva Magnowski  
**Cc:** Jessica Guzman  
**Subject:** [External] FOIA Request Form

**Follow Up Flag:** Follow up  
**Flag Status:** Flagged

**External Sender - From: (noreply@revize.com)**  
This message came from outside your organization.

[Learn More](#)

First\_Name = Steven

Last\_Name = [REDACTED]

Address = [REDACTED]

Email = s[REDACTED]

Phone = 847-666-1818

Requested\_Records = 1) All correspondence in the past year regarding the property located at 312 Flora Avenue, Glenview Illinois

2) Correspondence received or sent in the past year regarding the parking of work vans in front of 312 Flora Avenue

3) all citations or code violations issued or sent in the past year regarding the property at 312 Flora Avenue

4) All codes, ordinances, rules or regulations regarding the parking of work vans on, near or adjacent to properties located in the Township during daylight or evening hours

Inspect\_or\_Copy = Copy

Commercial\_Purpose = No

How\_Receive = Email

Client IP = 23.25.60.161

Eva Magnowski

**From:** John Link <recordrequest+15754.1775617564801@govrecordrequest.com>  
**Sent:** Tuesday, April 7, 2026 10:06 PM - Received after hours  
**To:** Eva Magnowski  
**Subject:** [External] IFOIA Request: 2022 Street Maintenance Materials

**Follow Up Flag:** Flag for follow up  
**Flag Status:** Flagged

**External Sender - From:** (John Link <recordrequest+15754.1775617564801@govrecordrequest.com>)  
 This message came from outside your organization.

[Learn More](#)

Dear Maine township,

This is a request for public records made under IFOIA and the common law right of access. Please confirm receipt of this message. Kindly send all responsive documents electronically — either by replying directly or emailing the address below. This unique address helps me organize my requests, so please use it exactly as shown:

[recordrequest+15754.1775617564801@govrecordrequest.com](mailto:recordrequest+15754.1775617564801@govrecordrequest.com)

**Records requested:**

Please send the final and compiled bid tabulation (bid tally), including all quantities and unit pricing for each bidder, for **'2022 Street Maintenance Materials'** that was submitted on **06/01/2022**. I believe the project number is **'2'**, but I could be mistaken. If so, please use the project name and date to lookup the responsive documents. We specifically request the **line-item bid tabulation** showing each material, quantity, unit, and unit price for every bidder. If no such line-item tally was created, please provide the full bid submissions from each contractor. A **grand total sheet alone is not sufficient** to satisfy this request unless it was a lump sum bid.

Below is an example of the format we are looking for that the engineer usually creates at the completion of the bid:

				BIDDER 1		BIDDER 2	
Item #	Material	Quantity	Unit	UNIT PRICE	TOTAL	UNIT PRICE	TOTAL
1	...	...	...	...	...	...	...
	GRAND TOTAL		GRAND TOTAL				

**Common law access / Public interest justification / Fee waivers:**

My public interest justification is as follows:

- Bid tabulations obtained through this request are made publicly available at no cost. This ensures that taxpayers, businesses, journalists, and policymakers have free access to procurement data that impacts public funds.
- Transparency and accountability: Publicly available bid results help prevent overpricing, bid-rigging, and favoritism in public contracts.
- Support for small businesses: Many firms, especially small and minority-owned businesses, rely on bid history to compete fairly in government contracting.
- Cost savings for taxpayers: Open access to bid tabulations promotes competition, leading to more cost-effective government spending.

**Attestations:**

- I am a citizen of the United States and affirm my full name and contact information is true and correct.
- I have not been convicted of any indictable offense under the laws of any state whatsoever nor the United States.
- I, or another person, will not use the requested government records for a commercial purpose.
- I am not seeking records in connection with a legal proceeding.

**Compliance Matters:**

Should you need it, my mailing address is 66 Main St #55, Farmingdale, NJ 07727, and my phone number is (732) 444-7051. For any compliance matters or other questions \*not related\* to the responsive record, please email our general counsel at legal[at][govrecordrequest.com](mailto:legal@govrecordrequest.com). Please do not send responsive records to that address.

Thank you!

Yours faithfully,  
John Link

**Eva Magnowski**

---

**From:** noreply@revize.com  
**Sent:** Thursday, April 16, 2026 3:06 PM  
**To:** Eva Magnowski  
**Cc:** Jessica Guzman  
**Subject:** [External] FOIA Request Form

**External Sender - From: (noreply@revize.com)**

[Learn More](#)

This message came from outside your organization.

First\_Name = Amy

Last\_Name = [REDACTED]

Address = [REDACTED]

Email = [REDACTED]

Phone =

Requested\_Records = Hi, we want to request property information of 9408 Noel Ave, Des Plaines, IL, 60016 or 9408 Noel St, Des Plaines, IL, 60016, as both addresses refer to the same property. We're in the process of purchasing it and would like to pull any permit records, history of damages/floods/other claims, utilities, inspections, communications and anything else you can find really. Thank you!

Inspect\_or\_Copy = Copy

Commercial\_Purpose = No

How\_Receive = Email

Client IP = 194.242.49.253